



# ***Dynaflow***

## ***Hood***

### ***Installation and Maintenance Manual***

---

Spring Air Systems Inc., Oakville, Ontario  
Phone (905) 338-2999, Fax (905) 338-0179, [info@springairsystems.com](mailto:info@springairsystems.com)

2010 Revision 2.0

# Dynaflow Installation and Maintenance Manual

## Table of Contents

Introduction	1
Spring Air Systems Hood Model Number Designations	2
Dynaflow MB Hood Principle of Operation	2
Three Fresh Air Boundary Regions	3
Standard Dynaflow MB hood specification	3
Dynaflow MJ Hood Principle of Operation	4
Standard Dynaflow MJ hood specification	5
Dynaflow Installation	5
Arrangement “D” Exhaust Fire Damper Assemblies	7
Link/Cable Assemblies for various exhaust duct collar sizes.	7
Adjusting the Fire Damper Blade Position	9
Grease Filter for Dynaflow Hoods	10
MJ Blower assembly for all MJ hoods	13
Special ‘K’ Grill	14
Dynaflow Maintenance Schedule	15
Trouble Shooting and Cleaning	16
Measuring Exhaust Air flow with VE, HE, EC and Sa Filters	17
Measure Exhaust Air Flow with CA Filters	21
Measuring Dynaflow MB Supply	23
A. Measuring the Appliance Region	23
B. Adjusting the MB Blade to change velocity at the appliance region.	24
C. Adjusting the air velocity to the Chef Region.	24
C. Measuring the Supply Discharge velocity from the MB Blade.	25
Measuring Dynaflow MJ Plenum Air	26
A. Measuring the Appliance Region	26
B. Adjusting the MJ Blower to change the appliance region velocity	27
C. Adjusting the air velocity to the Chef Region	27

# Dynaflow Hood Installation and Maintenance Manual

## INTRODUCTION

Thank you for selecting a SPRING AIR SYSTEMS INC. Dynaflow commercial kitchen exhaust hood. The *Dynaflow* hood is an innovative idea in commercial kitchen ventilator design that provides for the total kitchen comfort, particulate capture and energy efficiency.

**People comfort.** The fresh air introduced through the make up air plenum utilizes the Comfort Tuning Blade to provide a comforting breeze for the people working under the kitchen hood.

**Balanced air flow design:** The kitchen hood exhaust air and fresh air introduced into the kitchen space are always balanced, reducing drafts, hot and cold spots and improving particulate capture.

**Low exhaust volumes:** The exhaust volume is minimized with dynaflow technology to maximize your energy savings.

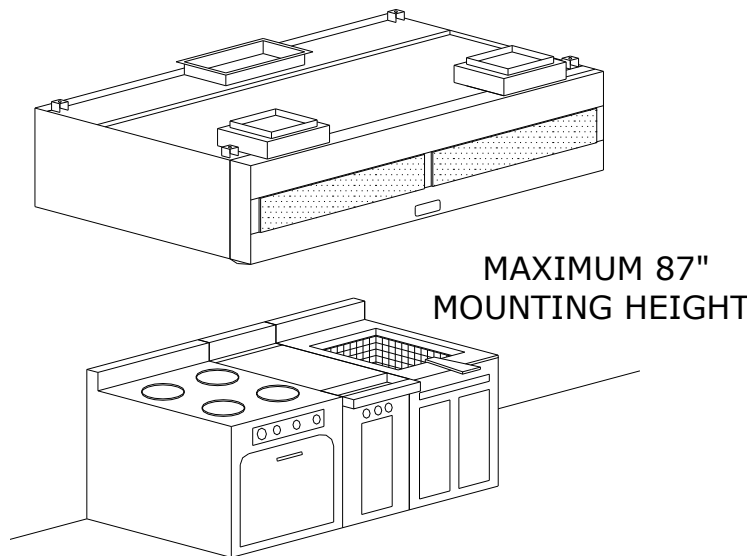

*Typical Dynaflow FN-B-MB Hood*  
*Figure 1*

The Spring Air Systems Inc. Dynaflow hood was selected to best meet the design requirements of your commercial kitchen application.

The Dynaflow hood is a NFPA-96 Type 1 listed for use with all temperature ranges on single row; wall mounted, island double row cooking or island single row cooking equipment lineups, The hood is ceiling hung with a maximum mounting height of 87" (2209 mm) from the lower front edge of the canopy to the floor and (52" (1320mm) from the surface of the cooking equipment to the lower edge of the grease extractor). The box canopy can be tapered to 11" (279 mm) at the front. The hood is finished with a number 4 finish on exposed sides. The *Dynaflow* hood is available with fluorescent, incandescent, recessed incandescent or LED lights wired to a J-box.

The Dynaflow hood is equipped with UL/ULC listed grease filters or cartridges. Five extraction types are available with Dynaflow.

- VE - standard grease extraction efficiency Stainless steel baffles.
- CA - Medium grease extraction efficiency cartridges with adjustable flow baffles.
- HE - High grease extraction Efficiency Cascade baffles for Enviro applications and reducing grease discharge from buildings.
- EC - Easy Clean Teflon – standard grease extraction efficiency baffles for hot, heavy grease laden appliances.
- SA - Spark Arrestor – standard grease extraction efficiency, for solid fuel appliances.

## Model Number Designation

Sample Model Number

### F N B MB (VE)

F= Filter Hood

N= Exhaust duct collar with no fire damper, listed under

D= Exhaust duct collar with fusible link fire damper

B = box canopy

DS= double box canopy single row appliance

DB= double box canopy double row appliance

MB= Dynaflow type hood with Tri-Zone control System

MJ= Dynaflow type hood with Perimeter Defense control System

VE= standard grease extraction efficiency Stainless steel baffles.

CA= Medium grease extraction efficiency cartridges with adjustable flow baffles.

HE= High grease extraction Efficiency Cascade baffles for Enviro applications and reducing grease discharge from buildings.

EC= Easy Clean Teflon – standard grease extraction efficiency baffles for hot, heavy grease laden appliances.

SA= Spark Arrestor – standard grease extraction efficiency, for solid fuel appliances.

### Dynaflow MB hood

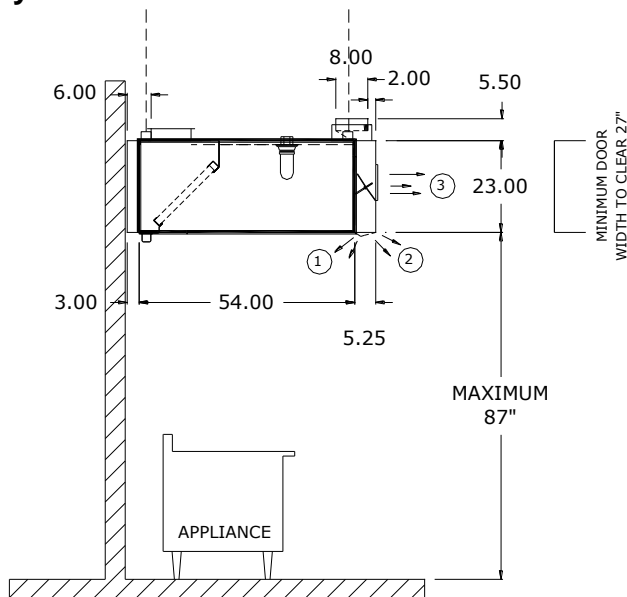

*Dynaflow FN-B-MB Hood Section  
View with standard VE filters.*

*Figure 2*

### Principle of Operation

The *Dynaflow* design provides the lowest minimum exhaust. The *Dynaflow* hood exhaust volume is based on the appliances below the hood. It's a simple adjustment to fine-tune your ventilator to provide excellent smoke capture with maximum grease extraction.

Heated and/or cooled fresh air ducting is connected to the supply duct collar(s) on the top, front of the hood. The fresh air enters the fire damper in each supply duct connection and then discharges into the *Dynaflow* plenum. Within the plenum the fresh air is routed to three (3) regions within the boundaries of the appliances.

### Three Fresh Air Boundary Regions

1. **Appliance Region:** Fresh air discharges down through a full length S/S perforated panel, creating an air curtain around the perimeter of the hood within the boundary of the kitchen appliances for excellent smoke capture with maximum grease extraction and to reduce each appliance net exhaust requirement.
2. **Chef Region:** Fresh air discharges down through a full length S/S perforated panel towards the chef for a more comfortable work environment in front of the hood.
3. **Kitchen Ambient Region:** The horizontal fresh air discharges through a s/s perforated panel out the front of the hood into the kitchen to provide the exact amount of air to balance the kitchen and ensure optimum capture

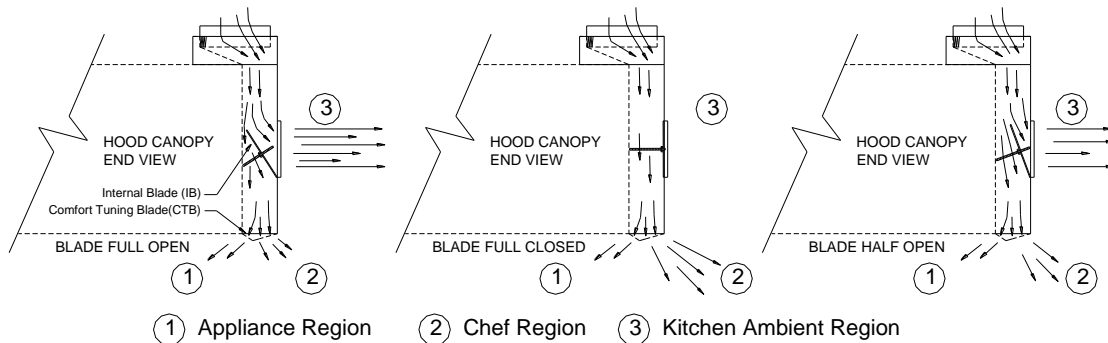

*Fresh Air Regions  
Figure 3*

The internal blade (IB) is adjusted to direct fresh air between the Kitchen Ambient (3) Region, the Appliance (1) Region, and Chef (2) Region. The Comfort Tuning Blade (CTB) is adjusted to direct fresh air between the Appliance (1) Region and the Chef (2) Region. The complete kitchen ventilation system is always balanced. The IB and CTB are adjustable every 24" (610mm) along the length of the Dynaflow hood to match the appliances underneath. Dynaflow operates with the lowest minimum exhaust. After your kitchen is complete, appliances can be Relocated, Added, or Removed from under the hood while maintaining maximum capture and chef comfort within the commercial kitchen.

### Standard Dynaflow MB hood Specification

The unit casing shall be a minimum 18 GA. stainless steel, with No. 4 finish on all exposed surfaces. The hood shall include UL/ULC listed grease filters mounted in an integral stainless steel rack inclined at 45 degrees. The filter rack shall include a full length stainless steel grease gutter and grease cup.

The optional exhaust fire damper shall be an arrangement "D", butterfly type, constructed of stainless steel with blade and edge seals. The fire damper shall be activated by a fusible link and dead weight arrangement.

The Dynaflow plenum provides all the fresh air required for the commercial kitchen. The fresh air is routed to three (3) regions within the boundaries of the appliances. Each region includes an aerodynamically designed s/s perforated discharge panel.

The first (1) region discharges through a full length s/s panel located at the bottom of the Dynaflow plenum. Fresh air is directed through the Comfort Tuning Blade (CTB) towards the appliances providing maximum exhaust air reduction. The second (2) Region discharges through a full length s/s angular panel located at the bottom front of the Dynaflow plenum. The fresh air is directed towards the chef to provide a more comfortable work environment in front of the hood. The third (3) region provides horizontal discharge of fresh air through a s/s perforated panel out the front of the hood into the kitchen. The third region provides the exact amount of fresh air to balance the kitchen and ensure optimum capture.

The s/s front discharge shall include multiple s/s perforated panels for the full length of the hood. A manually operated Internal Blade (IB) damper shall be located behind each front s/s discharge panel. The CTB and IB dampers are field adjustable through the lower s/s discharge panel. The hood shall have \_\_\_\_\_ incandescent/fluorescent/recessed/incandescent/LED lights evenly spaced along the length of the hood. Optional Sideflow right and/or left MJ blower assemblies are available.

# Dynaflow MJ hood

## Principle of Operation

The MJ Perimeter Defense design exhaust volume is based on the appliances under the hood. It's a simple calculation to determine your best exhaust volume for any commercial kitchen lineup. The MJ Perimeter Defense hood can be fine-tuned to provide excellent smoke capture with maximum grease extraction. A MJ tangential blower is mounted on top of the plenum. Return air from the ceiling is drawn into the blower inlet through removable washable aluminum mesh filters. The tangential MJ blower discharges air through a fusible link fire damper into the MJ plenum. The air is then discharged from the bottom through a two way adjustable perforated grill. The air is then proportioned between the appliances and the chef area by adjusting the comfort tuning dial. This is not fresh air from outside the building. Fresh supply air must still be introduced somewhere else in the commercial kitchen.

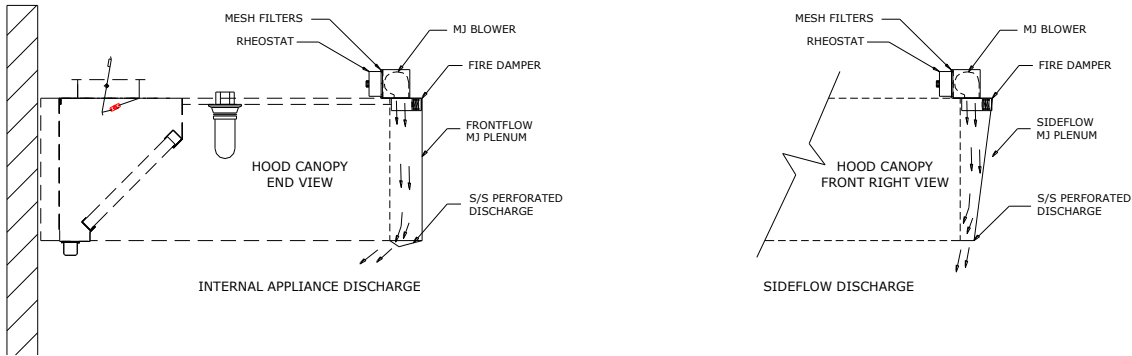

*MJ Perimeter Defense Operation*  
Figure 4

Introducing supply air back into the kitchen is good engineering practice. An adequate supply of fresh air eliminates cold drafts, and hot spots, enhances the capture capability of the hood and results in a more comfortable kitchen environment. A supply air volume of at least 80% of the total exhaust is recommended. The fresh air should be tempered to between 55 and 75F (13 to 24C). Direct the fresh air to separate diffusers surrounding the hood located in the finished ceiling. The diffusers must be located to eliminate short circuiting the exhaust and drafting. Consult with factory for recommended kitchen diffuser locations. If the hood is required to supply the fresh air directly refer to the Spring Air MB DYNAFLOW specification sheet

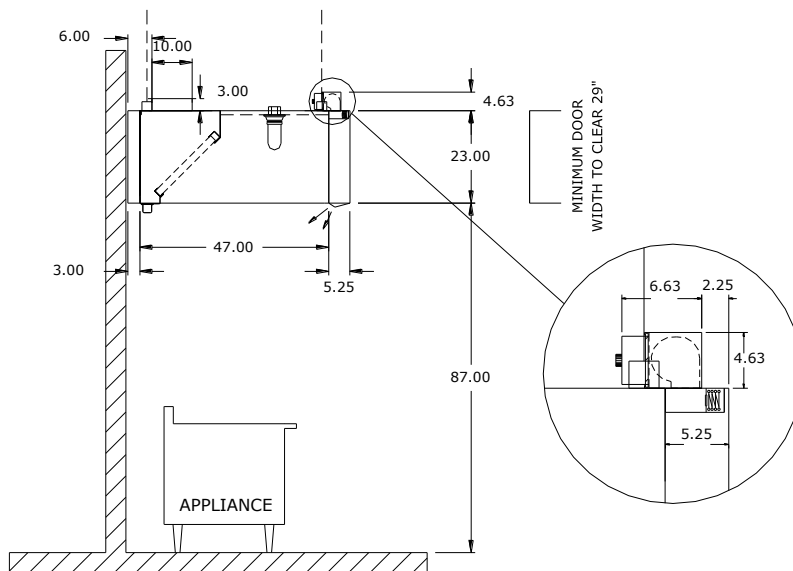

*Dynaflow FN-B-MJ Hood Section View with standard VE filters.*  
Figure 5

## Standard

### Dynaflow MJ hood Specification

The unit casing shall be a minimum 18 GA. stainless steel, with No. 4 finish on all exposed surfaces. The hood shall include UL/ULC listed grease filters mounted in an integral stainless steel rack inclined at 45 degrees. The filter rack shall include a full length stainless steel grease gutter and grease cup.

The MJ blower provides ceiling return air to the MJ plenum which discharges out the bottom of the plenum through a s/s perforated plate along the length of the MJ plenum. The return air is directed through the MJ plenum towards the appliances. MJ blower(s) mounted on top of the plenum shall be complete with adjustable Triacs, washable filters and wired to a common J-box on top of the hood. A fusible link fire damper is located below each MJ blower.

The hood shall have \_\_\_\_\_ incandescent/fluorescent/recessed/incandescent/LED lights evenly spaced along the length of the hood. Optional Sideflow right and/or left MJ blower assemblies are available.

### Dynaflow Installation

The Dynaflow hoods are hung from 4 or more hanging brackets (depending on the model) mounted on top of the hoods as indicated on the engineering drawings. The engineering drawings indicate number and location of the hanger bracket. **All hanger brackets shown on the Spring Air Systems drawings must be used to support the hood. Spring Air Systems assumes no responsibility for the field installation of the any hood.**

A typical schematic is shown to the right with recommend method on installing the hanger rods to the hanger brackets. The size of the hanger rods, washers and nuts must be determined by a structural engineer based on hood weight and site conditions. All hood weight is shown on the Spring Air Systems section view drawing. The hanger rods must be size to safely hold the weight of the hood from the structure above. The structure above must be designed to hold the weight of the hood. Structural engineers will be required to determine what is acceptable. The hanger bracket diagram indicates how the rod is attached to the hood. All hanger rods must be installed perpendicular to the roof of the hood.

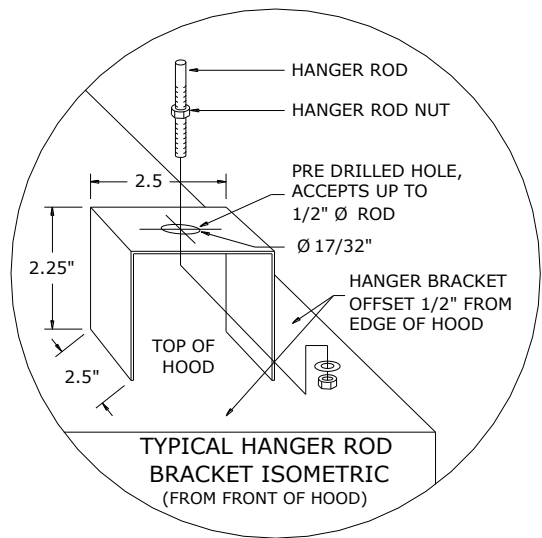

*Hanger Rod Schematic  
Figure 6*

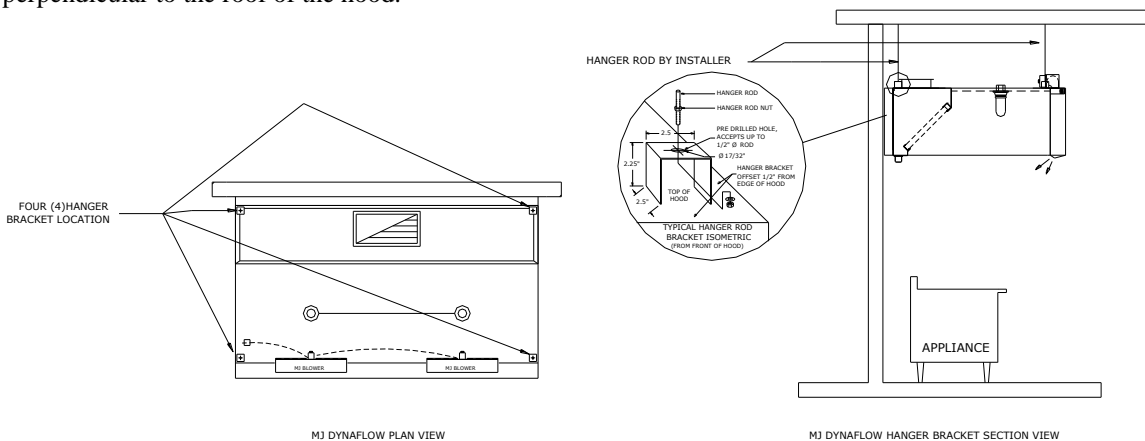

*Wall mounted Dynaflow model FN-B-MJ Hood in Plan and Section View showing hanger rod locations.  
Figure 7*

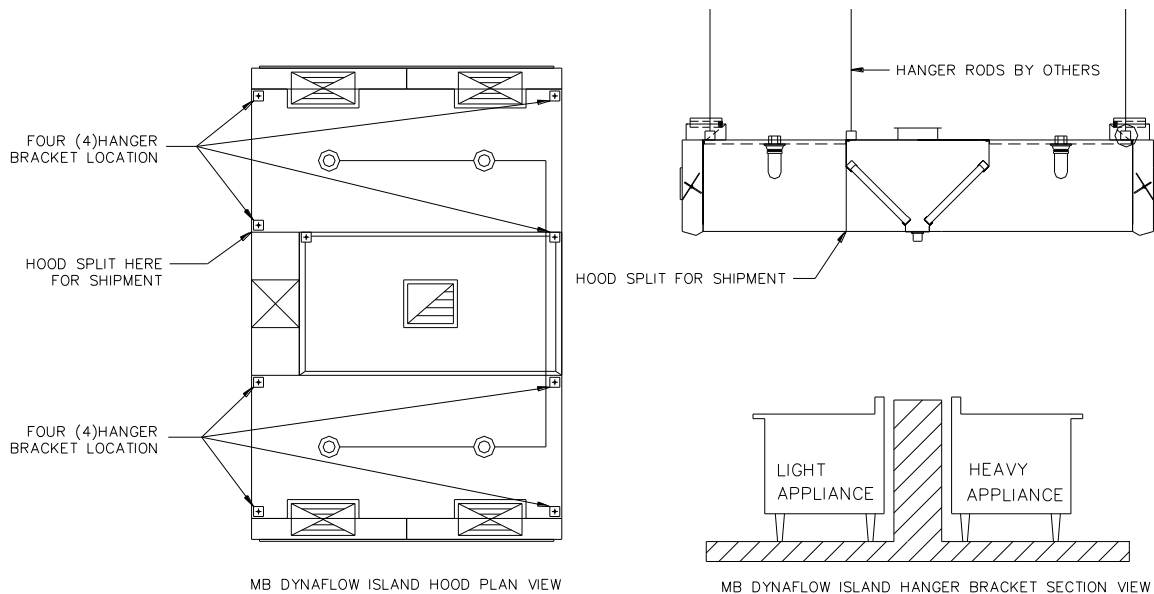

*Typical Island Dynaflow model FN-DB-MB in Plan and Section View showing hanger rod locations.  
Figure 8*

Your Dynaflow hood must be installed in accordance with the building permit issued for the commercial kitchen. The hood may be mounted against a wall or in an island configuration.

The Dynaflow hood must be installed in accordance with the current edition of the NFPA-96, all local building codes, all state or provincial building codes, all national building codes, and the authority having jurisdiction.

A commercial kitchen exhaust fan must be installed on the roof or wall mounted and connected to the hood by liquid tight all welded duct in accordance to the current edition of the NFPA-96. A dedicated fresh air unit may also be installed depending on the local code requirements for your area. Place the hood on the ground in the position it will hang below the hanger rods. The hood must rest on wood 2"x 4" or some other soft material to prevent damages to the bottom edges. When lifting the hood, support from the underside at the four corners. Otherwise the hood ends or sides may buckle. Lift the hood straight up. Do not remove the lifting device until the hood is secure. After the hood is securely hung the exhaust and supply ductwork can be connected.

### **Welding the Exhaust Duct to the Hood Exhaust Duct Collar**

A "FD" Dynaflow hood is supplied with an Exhaust duct collar fire damper in the hood exhaust duct collar. The fire damper must be closed before welding the hood duct collar to the exhaust duct. We recommend the exhaust duct be continuously welded to the exhaust duct collar of the hood per the current edition of the NFPA-96. The fire damper is closed by removing the link/cable assembly from the hook on the inside of the hood exhaust duct collar. Check to ensure the damper moves freely open and closed within the exhaust duct collar after installation of the exhaust duct. Once the welding is complete the link/cable assembly must be connected to the hook to open the fire damper. See the next section for details on the cable/link assembly.

Supply ductwork, electrical wiring and plumbing must be installed in accordance with all applicable municipal, state, provincial and national codes.



## ARRANGEMENT “D” FIRE DAMPER ASSEMBLIES:

**Provide on all FD Dynaflow Hoods.**

**(FN Hoods do not have a fire damper in the exhaust duct collar)**

### Description:

The section view of the exhaust fire damper to the right shows a cross section of the exhaust duct collar, fire damper blade, fusible link, adjustable cable block, spring, and stainless steel cable when the damper is in the set position.

In the event of a fire in the exhaust duct collar, the fusible link melts, releasing the fire damper, which closes tight on the damper blade stops and seals. The second drawing shows the damper as the fusible link has been removed. The damper will rotate clockwise against the damper bar weight and close.

The complete assembly is part of the UL/ULC listed Spring Air Systems “Commercial Kitchen Exhaust Hood with Fire Damper”.

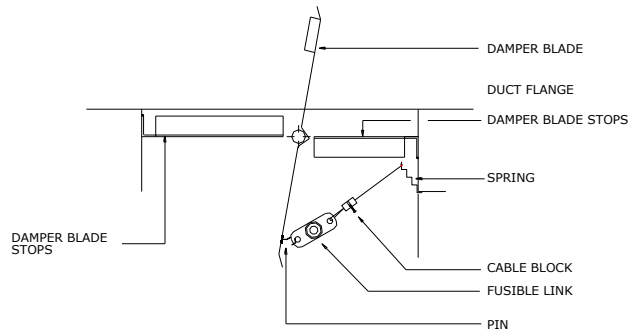

SECTION VIEW OF ASSEMBLE FUSIBLE LINK

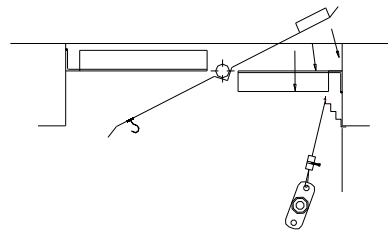

SECTION VIEW OF DISASSEMBLE FUSIBLE LINK

*Link/Cable Assembly  
Figure 9*

## Link/Cable Assemblies for various Exhaust Duct Collar Sizes.

**Dampers up to 18” long:**

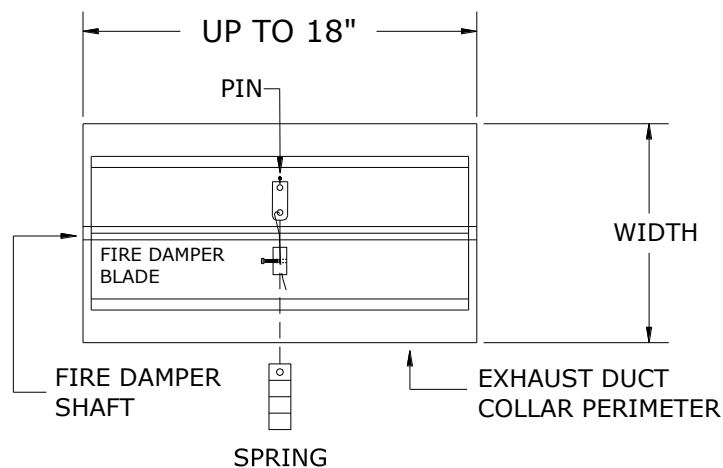

*Exhaust Fire Damper up to 18” long  
Figure 10*

**Dampers up over 18" up to 32" long**

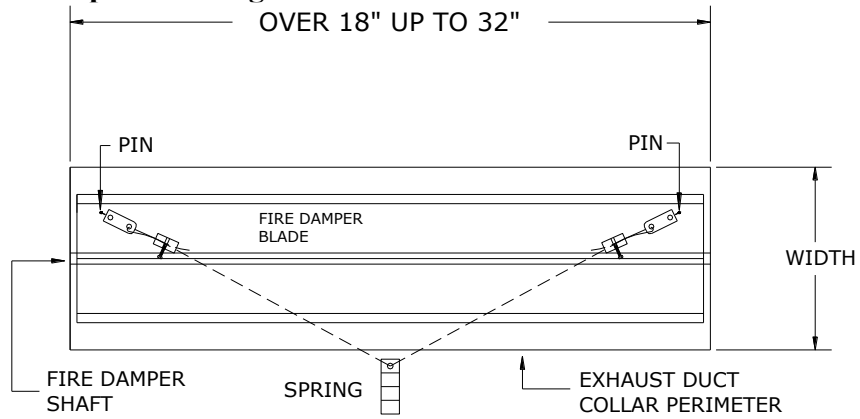

UNDERSIDE OF TOP OF HOOD

*Exhaust Fire Damper up to 18" to 32" long  
Figure 11*

**Dampers up over 32" long**

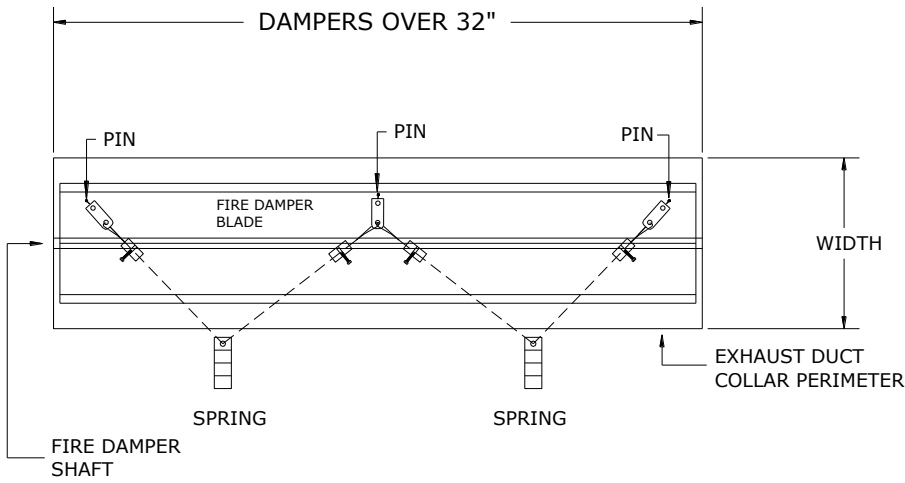

UNDERSIDE OF TOP OF HOOD

LEGEND	
	CABLE BLOCK
	FUSIBLE LINK
	S/S FUSIBLE LINK CABLE
	PIN WELDED TO FIRE DAMPER BLADE
	SPRING WELDED TO DUCT COLLAR

*Exhaust Fire Damper over 32" long  
Figure 12*

## ADJUSTING THE DAMPER BLADE POSITION:

The fire damper fusible links, springs and cable blocks are all accessible through the front on the hood. For filter hoods remove the baffle filters under the opening of the duct collar(s) of the hood. For dry extractors and cartridge remove the inserts under the opening of the duct collar(s) of the hood.

A single, double, and triple fusible link assembly is shown above. The blade position is adjusted by removing the fusible link/cable and block assembly from the damper pin. The fire damper will close and the complete assembly will hang loose from the spring. Loosen the set-screw on the adjustable block and pull the stainless steel cable through the block to open the damper or release cable from the stainless steel block to close the fire damper. Once the correct position is reached, re-tighten the set screw on the adjustable block and re-attached the fusible links on the damper pins.

The single fusible link damper has one block to adjust. The double fusible link damper has two blocks to just and the three fusible link dampers have up to four blocks to adjust.

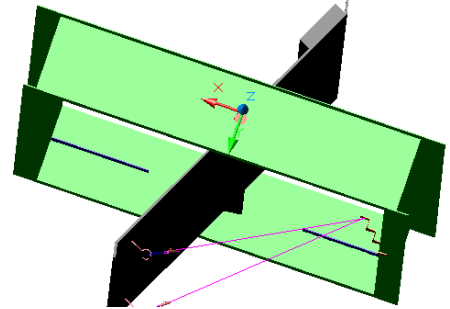

*Two fusible link Damper  
Figure 13*

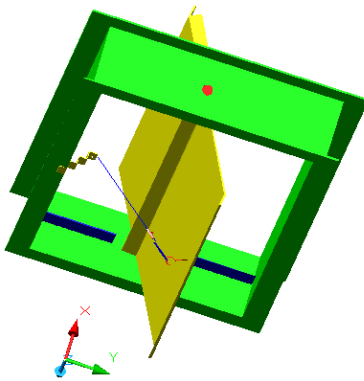

*Single Fusible link Damper  
Figure 14*

## Grease Filters for Dynaflow Hoods

### VE- Stainless Steel Baffle Filters

The exhaust air accelerates through two 90 degree turns within the baffle filters. The liquefied grease then drains down the vertical length of the baffles to the grease trough and into a grease cup.

Each grease baffle contains weeping holes to allow the liquid grease to drain into the grease trough.

Always ensure that the grease filters are installed with the weeping holes down toward the grease trough.

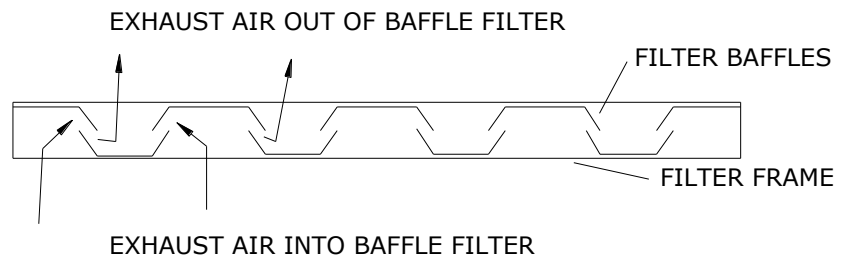

*Cross Section of Baffle Filter  
Figure 15*

Put the Baffle Filter in a dishwasher or in a pot sink in a detergent and water mixture to soak or spray the inner surfaces with hot water and detergent to clean.

### CA- Stainless Steel Cartridge Filters

The Cartridge Filter provides high efficiency grease extraction at an economical price. Unlike standard baffle filter grease extraction is carried out inside the Cartridge Filter not on any visible surface. The Cartridge Filter is always aesthetic pleasing because the smooth stainless steel surface does not collect oil or grease. The Cartridge Filter can be removed for easy cleaning. Each cartridge is also adjustable for various exhaust volume.

#### Easy Cleaning

Remove the Cartridge Filter Module from the hood rack and take note of the location of each module if the settings vary across the hood. Remove the Cartridge Filter Baffle from the Module by taking out two wing nuts; located in module air inlet.

Put the Cartridge Baffle along with the Module up side down in a dishwasher or just spray the inner surfaces with hot water and detergent.

Re-install the Cartridge Baffle in the Module with its proper initial air setting number and tighten the two wing nuts from the air inlet of the Module.

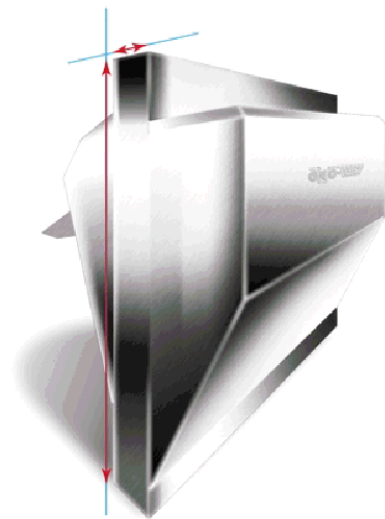

*CA Cartridge  
Figure 16*

### HE- High Grease Extraction Efficiency Cascade Filtration

Cascade high efficiency hood filtration captures more grease than standard filters, reduce grease damage, the hassle and expense of duct cleaning, cost much less than other high performance filters, and have lower static pressure.

Cascade is 270% more efficient (at 8 microns capture) than standard filters and removes 33% more grease than standard filters. This will result in less grease build up in the ducts and exhaust fan.

The Cascade is environmentally friendly reducing air pollution and odors. It reduces duct cleaning cut down on caustic cleaning chemicals.

Environmentally Friendly



*HE Cascade*

*Figure 17*

### Easy Cleaning

Remove the Cascade Module from the hood rack. Rotate the Locking Handles opposite the hinge on the Cascade to open the filter. Open the hinged Cascade and put it in the dishwasher or just spray the inner surfaces with hot water and detergent.

After cleaning just close the Cascade, lock the handles together and put them back in the hood filter rack.



*Cascade's locking handles open up the hinged design, allowing wide-open cleaning access.*

*Cascade shown in the Open Position*

*Figure 18*

### EC- Easy Clean Teflon Filters for Heavy Grease Applications.

Grease laden air is drawn into the filter by the exhaust fan. As the air starts through the aerodynamic "V" baffle system, it undergoes a series of compressions, expansions and pressure changes. The heavy grease is deposited safely and quickly on the baffles while the grease-free air passes through the filter and up the exhaust duct. The baffle's smooth surface enables the collected grease to run off into collection troughs without dripping on food utensils or burner surfaces. the ChG.

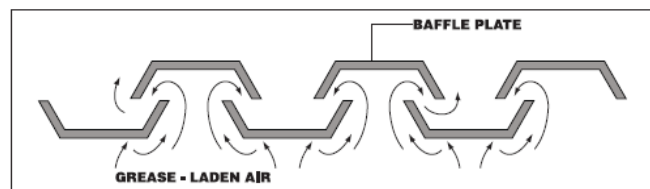

*EC – Easy Clean Teflon*

*Figure 19*

Because Flame Gard® removes grease aerosols from the air stream and drain them away instead of retaining them. there is no build-up of grease in the path of the air Flame Gard® therefore, insures a constancy of air never before achievable with mesh-type filters.

Flame Gard's high rate of grease extraction is aided by our TEFLON® coated baffle. In the same manner that grease rolls off a TEFLON coated pan, it rolls down our baffles, out of the filter and into the hood's remote collection cup. Because FlameGard's filters retain only insignificant amounts of surface grease and do not load, you will have constancy of air flow throughout your operating day.

The FlameGard's filters can be easily cleaned in a pot sink or dishwasher with simple detergent and hot water.

## **SA- Spark Arrestor Filters for Solid Fuel Appliance.**

### **CLASSIFIED BAFFLE GREASE FILTER MEETS NFPA 96 REQUIREMENT FOR COOKING WITH SOLID FUEL**

#### **SPARK ARRESTOR FRAME**

The 3/8" X 1/2" SPARK ARRESTOR FRAME MEETS NFPA 211 REQUIREMENT FOR SOLID FUEL BURNING APPLIANCES.

The filters are all steel construction, non-loading Teflon coated. If airborne sparks and embers can be generated by the solid fuel cooking operation, spark arrestor devices shall be used prior to the grease removal device to minimize the entrance of these sparks and embers into the grease removal device and into the hood and duct system.



*SA- Spark Arrestor Filter  
Figure 20*

#### **NFPA 211 CHAPTER 1.11.2 (B) STATES:**

(b) The arrestor screen shall have heat and corrosion resistance equivalent to 19 gauge (0.011 in.) galvanized steel or 24 gauge (0.024 in.) stainless steel.

(c) Opening shall not permit the passage of spheres having a diameter larger than 1/2 in. (12.7mm) nor block the passage of spheres having a diameter of less than 3/8 in. (9.5mm).

#### **94% EFFICIENT AT GREASE EXTRACTION!**

FlameGard's high rate of grease extraction is aided by our TEFLON® coated baffle. In the same manner that grease rolls off a TEFLON coated pan, it rolls down our baffles, out of the filter and into the hood's remote collection cup. Because FlameGard's filters retain only insignificant amounts of surface grease and do not load, you will have constancy of air flow throughout your operating day. In addition,

The Spark Arrestor FlameGard's filters must be washed daily to ensure proper operation of your hood filter assembly. They can be easily cleaned in a pot sink or dishwasher with simple detergent and hot water.

## MJ- Blower Assembly on Dynaflow MJ hoods.

Every Dynaflow with MJ Perimeter Defense control has one or more MJ Blower assemblies mounted on the top of the MJ plenum. The MJ blower assembly consists of a double shafted 120V/1/60 AC motor with one tangential blower attached to each shaft. The motor/blower sub assembly is inside a protective housing to discharge the air down into the top of the MJ plenum. The MJ blower assembly has two (2) removable washable pre-filters, and a J-box with rheostat mounted on the switch MTG plate. The return air from above the hood enters the washable filters, travels through the tangential blowers and discharges into the MJ plenum through a fusible line fire damper. Each MJ Blower assembly is bolted to four (4) studs on the top of the hood. The fire damper is accessed by removing the 4 bolts and lifting the MJ blower off the hood to reveal the fusible link fire damper.

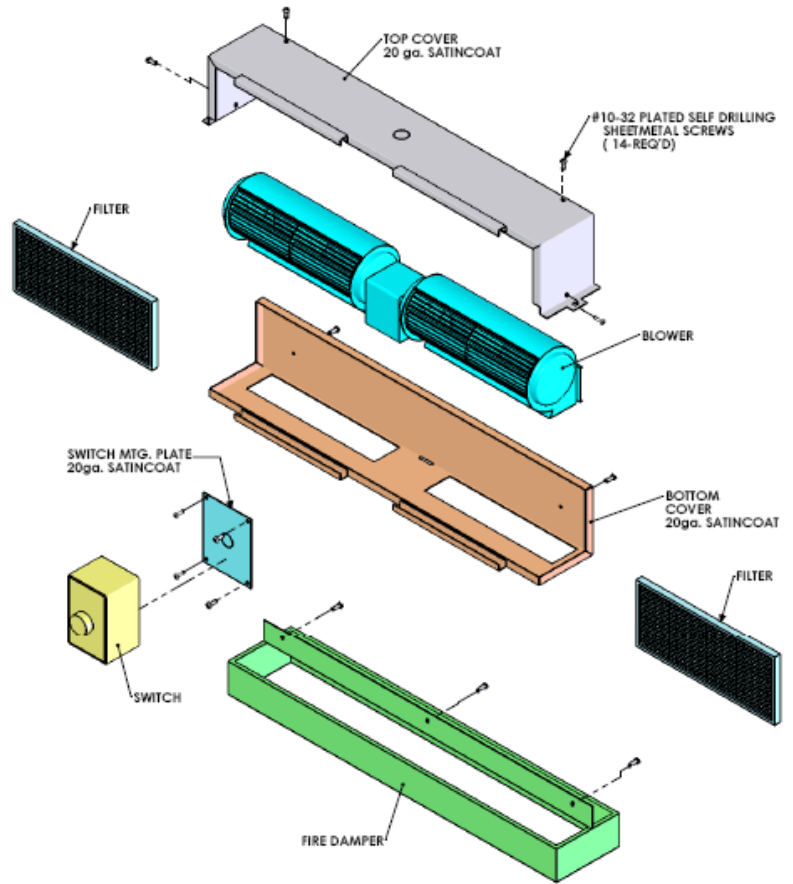

*Exploded View of MJ Blower assembly  
Figure 21*

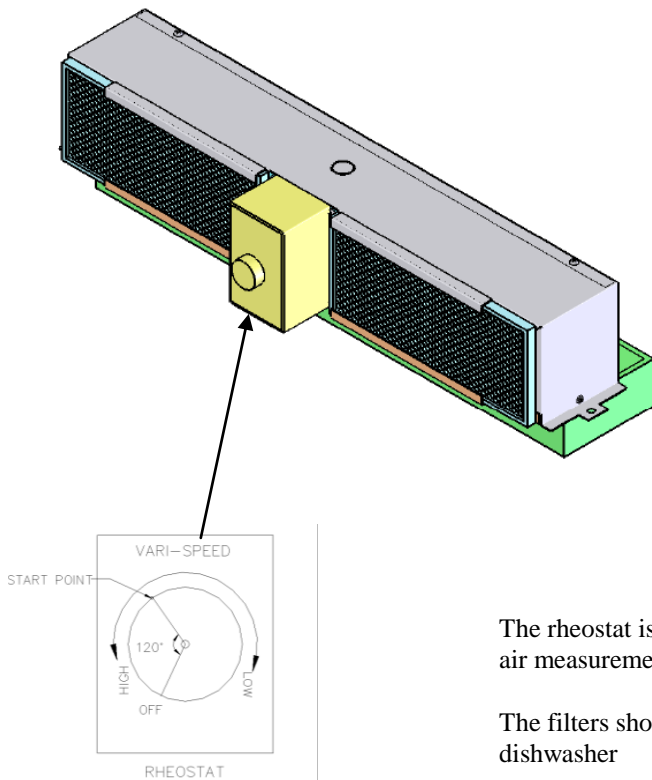

*Complete MJ Blower assembly  
Figure 22*

The rheostat is used to adjust the air discharge from the MJ Grille. See the air measurement section of the manual for more detail.

The filters should be removed and wash every two years in a pot sink or dishwasher

## Special “K” Grill

The implementation of the *Special “K”* grill will assist in keeping excess steam and vapors inside the hood until they can be cleared by the exhaust flow through the hood grease filters. These grills are used on hoods over combi steam ovens, tilting skillets and steam jacket kettles.



The design of the Special “K” grill allows the air curtain to move the steam-effluent directly back into the hood for better capture and containment. The front facing perforated grille allows some supply air to be pushed out into the kitchen when there is no MB grill on the plenum.



The Special “K” lower grilles can be ordered with the hoods or retrofitted to the hoods in the field. Field installation is easily done without welding on the Dynaflow plenums.



# DYNAFLOW MAINTENANCE SCHEDULE

## DAILY:

1. At the end of the cooking day wipe off the interior and exterior of the Dynaflow hood canopy and the underside of the grease trough with a damp cloth. Inspect the grease filters and clean if necessary.
2. Clean SA Spark Arrestor filter daily.
3. Inspect and clean HE High Efficiency filters daily as required.

## WEEKLY:

1. Remove all the grease filters and wash in a mild detergent and water mixture.

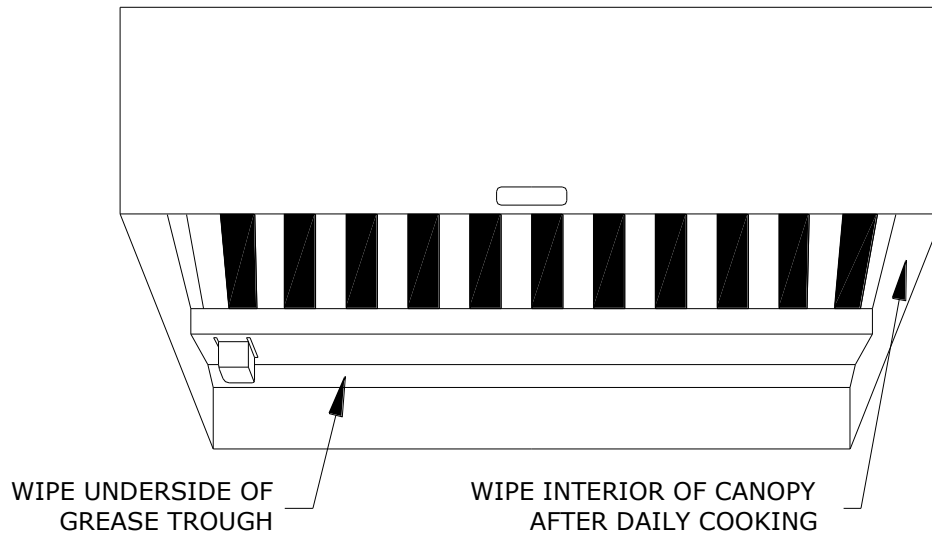

*Cleaning the Hood Exterior  
Figure 23*

Wipe off the interior of the filter hood plenum behind the grease filters and the interior and exterior of the grease trough. Remove the grease cup and clean if necessary.

## SIX MONTHS

1. Check the exhaust fan belts for alignment, tightness, and wear. Adjust and/or replace.
2. If the hood has an exhaust duct collar fire damper (Models "FD") inspect the exhaust fusible link fire damper. Clean and/or replace the fusible link if necessary.

## ONE YEAR

1. Check the exhaust fan belts for alignment, tightness, and wear. Adjust and/or replace.
2. If the hood has an exhaust duct collar fire damper (Models "FD") inspect the exhaust fusible link fire damper. Clean and/or replace the fusible link if necessary.
3. MB Dynaflow hoods replaced the supply duct collar fusible link.
4. MJ Dynaflow hoods replace the MJ plenum fusible link under the MJ Blower assembly.
5. MJ Dynaflow hoods measure the MJ Grill discharge and adjust MJ Blower assembly rheostat to set correct appliance velocity at the discharge.

## CLEANING THE EXTERIOR

Normal soil can be removed with a mild detergent and water mixture applied to a cloth.

To remove baked on grease, apply a cleanser to a damp cloth or sponge and rub on the metal in the direction of the polishing lines. DO NOT RUB IN A CIRCULAR MOTION.

Burnt deposits which do not respond can usually be removed by rubbing the surface with SCOTCH-BRITE Scouring pads or Stainless scouring pads. Do not use ordinary steel wool.

Heat tint can be removed by a vigorous scouring in the direction of the polish lines using SCOTCH BRITE or STAINLESS scouring pads in conjunction with a powdered cleanser.

## TROUBLE SHOOTING

### Low Exhaust air

1. Improper exhaust fan rotation.
2. Broken or slipping belt.
3. Exhaust ductwork inspection door open.
4. Obstruction in the ductwork.

### No Exhaust air

1. Start/Stop station not turned on.
2. Broken belt exhaust fan belt.
3. Exhaust fan overload tripped. Inspect the magnetic starter or VFD overload.
4. Exhaust fan disconnect open on the roof.
5. Exhaust fan breaker open at the breaker panel
6. Exhaust fan motor or fuse or breaker blown.
7. "FD" type Dynaflow hoods Exhaust Fire damper closed. Check fusible link.

### Poor Capture

1. Improper exhaust fan rotation.
2. Broken or slipping belt.
3. Exhaust ductwork inspection door open.
4. Obstruction in the ductwork.
5. "FD" type Dynaflow hoods Exhaust Fire damper closed. Check fusible link.
6. MB Dynaflow plenum fresh air supply fusible link fire damper closed.
7. MJ Dynaflow plenum fusible link fire damper closed.
8. MJ Dynaflow Blower not running. Not turned on, fuse blown, breaker open, motor burnt.
9. Dynaflow MB appliance air velocity too high. Adjust the MB Blade position to provide more fresh air out MB front and less to the appliances.
10. Dynaflow MB appliance air velocity too low. Adjust the MB Blade position to provide less fresh air out MB front and more to the appliances.
11. Dynaflow MJ appliance air velocity too low. Adjust the MB MJ blower rheostat to provide more air to the appliances region.

## Measuring Exhaust Air Flow with VE, HE, EC, and SA Filters

**VE=** standard grease extraction efficiency Stainless steel baffles.

**HE=** High grease extraction Efficiency Cascade baffles for Enviro applications and reducing grease discharge from buildings.

**EC=** Easy Clean Teflon – standard grease extraction efficiency baffles for hot, heavy grease laden appliances.

**SA=** Spark Arrestor – standard grease extraction efficiency, for solid fuel appliances.

## Measuring Instruments:

### VANAXIAL VELOMETER

Follow the instruments instruction manual to measure the exhaust volume at each filter. The instrument will either measure the total CFM or average velocity of each filter. Hold the instrument perpendicular to the face of each filter. The Velometer should be within 1” of the filter face for best results. Once the each filter average exhaust velocity has been measure use Chart No.1 to convert Average Filter Face Velocity to CFM.

The total exhaust volume is the sum total of each filter CFM.

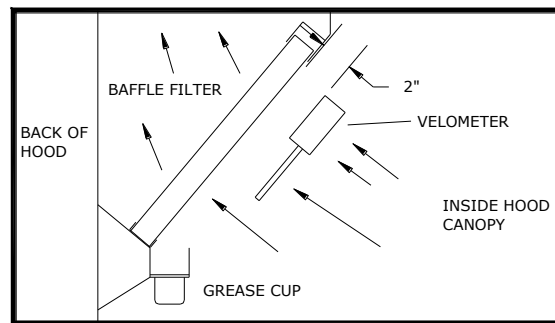

*Measuring Exhaust Air  
Figure 24*

### Exhaust Air Flow VS Average Filter Face Velocity

Baffle Filter		Average Filter Velocity					
Size		100 fpm/0.5m/s		200 fpm/1.0m/s		300 fpm/1.5 m/s	
in x in	mm x mm	CFM	l/s	CFM	l/s	CFM	l/s
16 x 16	406 x 406	160	75	320	151	480	226
20 x 16	508 x 406	200	94	400	189	600	283
20 x 20	508 x 508	260	123	520	245	780	368
20 x 25	508 x 635	320	151	640	302	960	453

*Chart No. 1*

## PITOT TUBE OR ANEMOMETER

Spring Air Systems has factory calibrated the average filter slot velocity VS filter CFM. Measure the average bottom slot velocity of each filter and use Chart No. 2 to convert the slot velocity to total filter CFM.

Each filter has a series of open and closed slots across the face. Hold the instrument perpendicular to the open filter slot at the bottom of the filter. Place the hot wire anemometer directly in the filter slot. Take one reading at the bottom of each slot as shown in Figure 25 below. Calculate the average slot velocity for each filter. Refer to Chart No.2 below for the corresponding filter exhaust volumes. Sum each filter CFM to determine the total hood exhaust volume.

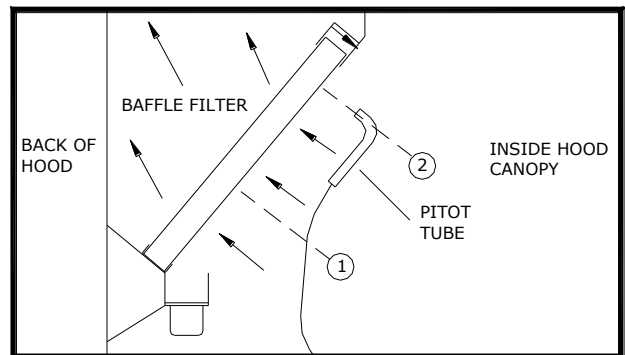
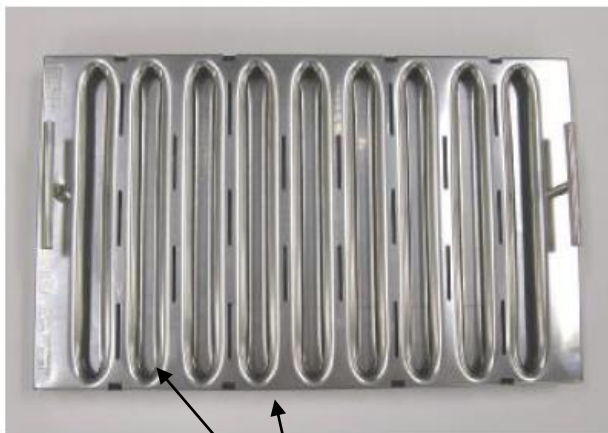

Measure velocity here at the bottom of the slot of each slot. Average the velocity across the filter and determine the CFM from Chart No. 2

*Measuring Exhaust Air  
Figure 25*

**VE/EC/SA STAINLESS STEEL FILTERS**  
**Average Slot Velocity vs CFM per Filter**

<b>Filter Slot</b>	<b>Filter Size VS CFM per Filter</b>			
<b>Velocity</b>	<b>16x16</b>	<b>20x16</b>	<b>20x20</b>	<b>20x25</b>
<b>(fpm)</b>	<b>(CFM)</b>	<b>(CFM)</b>	<b>(CFM)</b>	<b>(CFM)</b>
100	37	46	58	72
200	74	92	116	145
300	111	139	173	217
400	148	185	231	289
500	185	231	289	361
600	222	277	347	434
700	259	324	405	506
800	296	370	462	578
900	333	416	520	650
1000	370	462	578	723
1100	407	509	636	795
1200	444	555	694	867
1300	481	601	752	939
1400	518	647	809	1012
1500	555	694	867	1084
1600	592	740	925	1156
1700	629	786	983	1228
1800	666	832	1041	1301
1900	703	879	1098	1373
2000	740	925	1156	1445
2100	777	971	1214	1518
2200	814	1017	1272	1590
2300	851	1064	1330	1662
2400	888	1110	1387	1734
2500	925	1156	1445	1807
2600	962	1202	1503	1879
2700	999	1249	1561	1951
2800	1036	1295	1619	2023
2900	1073	1341	1676	2096
3000	1110	1387	1734	2168

*Chart No. 2*

**HE STAINLESS STEEL FILTERS**  
Average Slot Velocity vs CFM per Filter

<b>Filter Slot</b> <b>Velocity</b> (fpm)	<b>Filter Size VS CFM per Filter</b>			
	<b>16x16</b> (CFM)	<b>20x16</b> (CFM)	<b>20x20</b> (CFM)	<b>20x25</b> (CFM)
100	44	55	68	86
200	88	109	137	171
300	131	164	205	257
400	175	219	274	342
500	219	274	342	428
600	263	328	411	513
700	307	383	479	599
800	350	438	547	684
900	394	493	616	770
1000	438	547	684	855
1100	482	602	753	941
1200	525	657	821	1026
1300	569	712	889	1112
1400	613	766	958	1197
1500	657	821	1026	1283
1600	701	876	1095	1368
1700	744	931	1163	1454
1800	788	985	1232	1540
1900	832	1040	1300	1625
2000	876	1095	1368	1711
2100	920	1149	1437	1796
2200	963	1204	1505	1882
2300	1007	1259	1574	1967
2400	1051	1314	1642	2053
2500	1095	1368	1711	2138
2600	1138	1423	1779	2224
2700	1182	1478	1847	2309
2800	1226	1533	1916	2395
2900	1270	1587	1984	2480
3000	1314	1642	2053	2566

*Chart No. 3*

## Measuring Exhaust Air Flow with CA Cartridges

CA= medium efficiency cartridge with adjustable flow baffles.

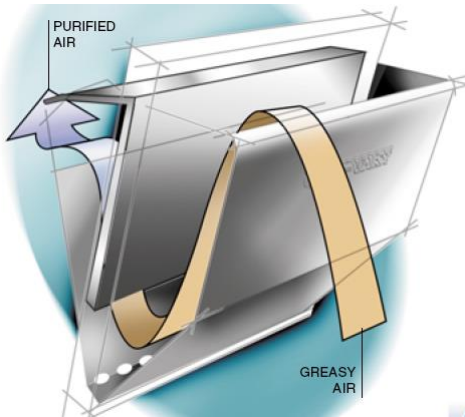

### Setting the Cartridge

Each cartridge is adjustable for various appliances. There are 6 settings. Closed, 1, 2, 3, 4, 5 and Open. The Open setting is for the heaviest appliance and the Closed setting is for the lightest appliances.

To adjust the setting to match the appliance:

- Loosen the two wing nuts located in the middle of the air inlet.
- Slide the baffle up or down so the top of the Cartridge coincides with the number engraved on the side of the module.
- Tighten the two wing nuts located in the module air inlet.

*Cartridge Filter Exhaust  
Figure 26*

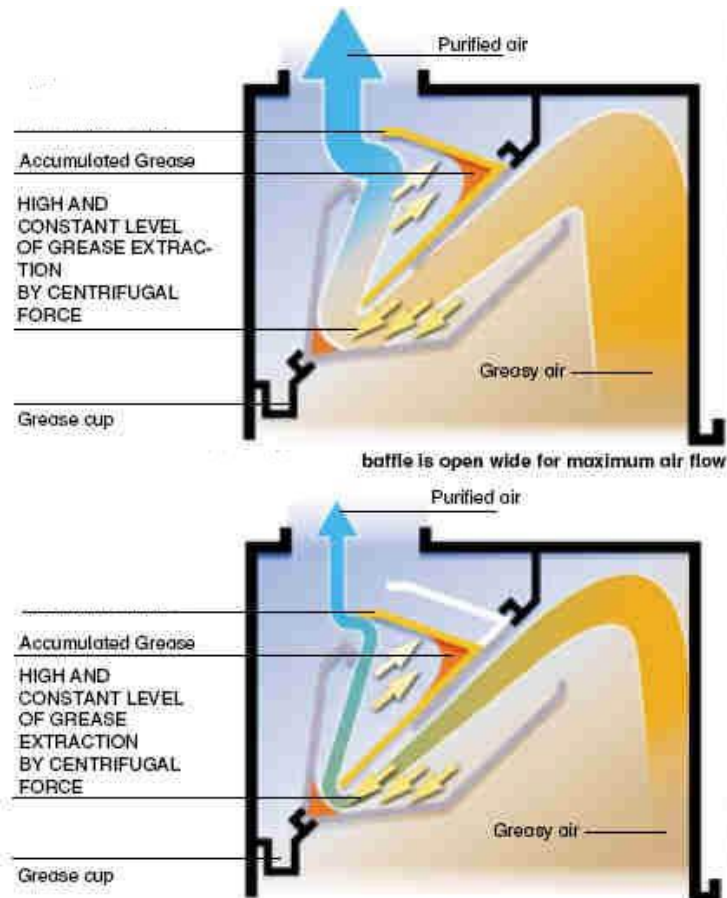

*Cartridge Adjustment  
Figure 27*

## Air Meter

Hold the probe so it is perpendicular to the throat opening and so the tip is about 30mm (3 inches) from the throat. Refer to Chart 1 to set Geo-Baffle.

## Setting Air Baffle in Modular Grease Extractor

- Loosen the wing nut located in the module air inlet.
- Slide the Geo-Baffle up or down so the top of Geo-Baffle coincides with the number engraved on the side of the module.
- Tighten the wing nut located in the module air inlet.

SIZE 16" x 10" (400mm x 250mm)					SIZE 16" x 16" (400mm x 400mm)				
DAMPER POSITION	DAMPER OPENING HEIGHT		CFM PER MODULE	L/s PER MODULE	DAMPER POSITION	DAMPER OPENING HEIGHT		CFM PER MODULE	L/s PER MODULE
	inch	mm				inch	mm		
OPEN	3.625	92	200	94	OPEN	3.625	92	320	151
5	3.000	76	180	85	5	3.000	76	288	136
4	2.125	54	160	76	4	2.125	54	256	121
3	1.625	41	140	66	3	1.625	41	224	106
2	1.125	29	120	57	2	1.125	29	192	91
1	1.875	48	100	47	1	1.875	48	160	76
CLOSED	0.250	6	80	38	CLOSED	0.250	6	128	60

SIZE 20" x 20" (500mm x 500mm)					SIZE 20" x 25" (500mm x 635mm)				
DAMPER POSITION	DAMPER OPENING HEIGHT		CFM PER MODULE	L/s PER MODULE	DAMPER POSITION	DAMPER OPENING HEIGHT		CFM PER MODULE	L/s PER MODULE
	inch	mm				inch	mm		
OPEN	4.500	114	500	236	OPEN	4.500	114	625	295
5	3.750	95	450	212	5	3.750	95	563	266
4	3.000	76	400	189	4	3.000	76	500	236
3	2.250	57	350	165	3	2.250	57	438	207
2	1.500	38	300	142	2	1.500	38	375	177
1	0.750	19	250	118	1	0.750	19	313	148
CLOSED	0.250	6	200	94	CLOSED	0.250	6	250	118

*Chart No. 4*



# Measuring Dynaflow MB Supply

## Dynaflow type hood with Tri-Zone control System

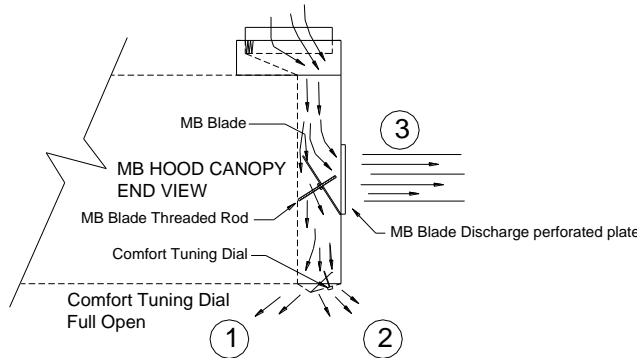

Each of the three regions must be measured to ensure proper hood operation. The Appliance Region, the Chef Region and the Kitchen Ambient Region as shown in the schematic Figure 28

The Appliance region is measured first.

- ① Appliance Region
- ② Chef Region
- ③ Kitchen Ambient Region

*Dynaflow MB Three Regions  
Figure 28*

### A. Measuring the Appliance Region

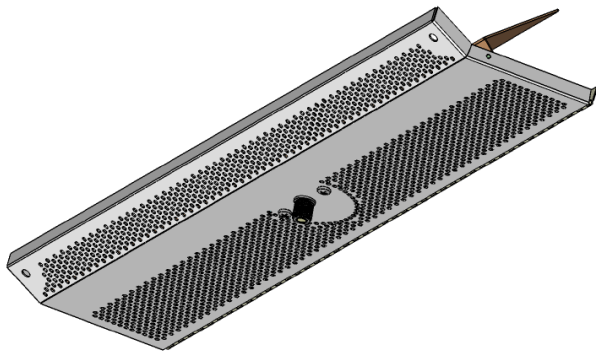

*MJGrill Discharge  
Figure 29*

The Appliance Region and Chef Region discharge is called a MJGrill. The MJGrill is manufactured as a single component shown on the left in Figure 29. The MJGrill includes the Appliance Region discharge, Chef Region discharge, and a adjustable Comfort Tuning Dial. The Comfort Tuning Dial proportions the amount of fresh air to the Chef Region.

The Comfort Tuning Dial on the MJ Grill has two colored dots; red and blue. The Comfort Tuning Dial proportions the volume of air to the chef. Turning the Comfort Tuning Dial towards the red dot provides less air to the Chef Region

and turning the Comfort Tuning Dial towards the blue dot provides more air to the Chef Region.

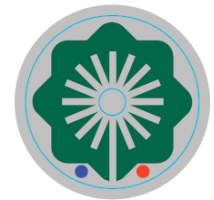

*Comfort Tuning Dial  
Figure 30*

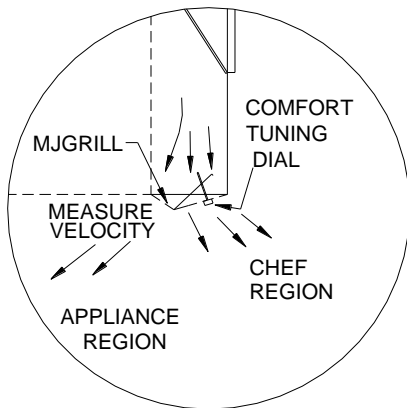

*Measuring the Appliance Region  
Figure 31*

To measure the Appliance Region air velocity rotate the Comfort Tuning Dial towards the red dot, counterclockwise to shut off air to the Chef Region. Now measure the velocity from the MJGrill perforated discharge towards the inside of the hood in the Appliance Region. The measurement can be made with a Hot Wire Anemometer or Vane Axial Velometer. The required air velocity is indicated below in Chart No. 5. "Hood Appliances VS Appliance Region Face Velocity"

If the velocity is too high or low the MB Blade must be adjusted to increase or decrease the velocity to the Appliance Region.

### Hood Appliances VS Appliance Region Face Velocity

APPLIANCES	Hood Length (ft)	Discharge Velocity (fpm)	
		FRONT	SIDE FLOW
		Set point	Set point
Heavy	9 - 14	500	450
	6 - 9	500	450
	4 - 6	550	450
	Up to 4	550	450
Medium/Light	9 - 14	450	400
	6 - 9	450	400
	4 - 6	450	450
	Up to 4	450	450

Chart No.5

#### B. Adjusting the MB Blade to change velocity at the appliance region.

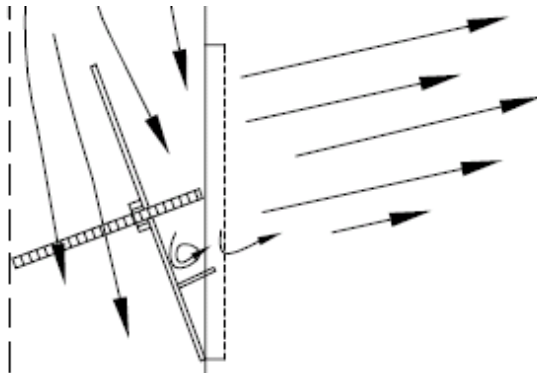

Open the MB Blade Face Discharge Grill on the front of the MB plenum located above the MJGrill that requires adjustment. The MB Blade perforated discharge grill is secured with four (4) Philips screws. Once the MB Blade discharge grill is removed in the center of the MB Blade is a threaded MB Blade adjustable Rod. To increase the velocity to the MJGrill below, rotate the threaded MB Blade Rod clockwise. To decrease the velocity to the MJGrill below, rotate the MB Blade Rod counter-clockwise. Measure the MJGrill discharge velocity after each adjustment until the correct velocity as indicated in Chart No. 5 “Hood Appliances VS Appliance Region Face Velocity is achieved.

Adjusting the MB Blade Threaded Rod  
Figure 32

#### C. Adjusting the air velocity to the Chef Region



The amount of air directed to the Chef Region is a personal decision. When commissioning an MB hood system we recommend the following:/  
 Heavy Appliances, Charbroilers, Woks: Rotate the Comfort Tuning Dial towards the blue dot to fully for maximum Chef air.  
 Medium Appliances, Griddles, and Ranges: Rotate the Comfort Tuning Dial towards the blue dot about three or four rotations clockwise.  
 Light Appliances, Ovens, and Kettles: Rotate the Comfort Tuning Dial towards the red dot to fully close the air to the Chef Region.

Comfort Tuning Dial  
Figure 33

## D. Measuring the Supply Discharge velocity from the MB Blade

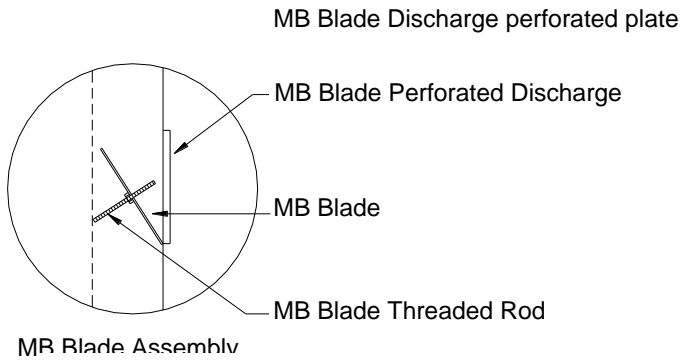

MB Blade Assembly

Measuring MB Blade Perforated Discharge

Figure 34

There are two sizes of MB Blade Discharge Grills. MBFront41x06 with a perforated discharge dimension of 41.5" wide x 6" high. The face area is 1.38sq feet

MBFront33x06 with a perforated discharge dimension of 33" wide x 6" high. The face area is 1.1 sq feet

When using a hot wire anemometer take 12 velocity readings at each discharge grill. Take 6 readings across the length and 2 rows. See Chart No. 6 "MB Face Velocity (fpm) VS MB Front volume (CFM)". below to convert the average velocity reading per grille to CFM.

**MB Face Velocity (fpm) VS MB Front volume (CFM)**

Average Velocity (fpm)	MBFront41x-6 (CFM)	MBFront33x06 (CFM)
50	69	55
75	104	83
100	138	110
125	173	138
150	207	165
175	242	193
200	276	220
225	311	248
250	345	275
275	380	303
300	414	330
325	449	358
350	483	385
375	518	413
400	552	440
425	587	468
450	621	495
475	656	523
500	690	550
525	725	578
550	759	605
600	828	660
625	863	688
650	897	715
675	932	743
700	966	770
725	1001	798

Chart No. 6

## Measuring Dynaflow MJ Plenum Air Dynaflow type hood with Perimeter Defense control System

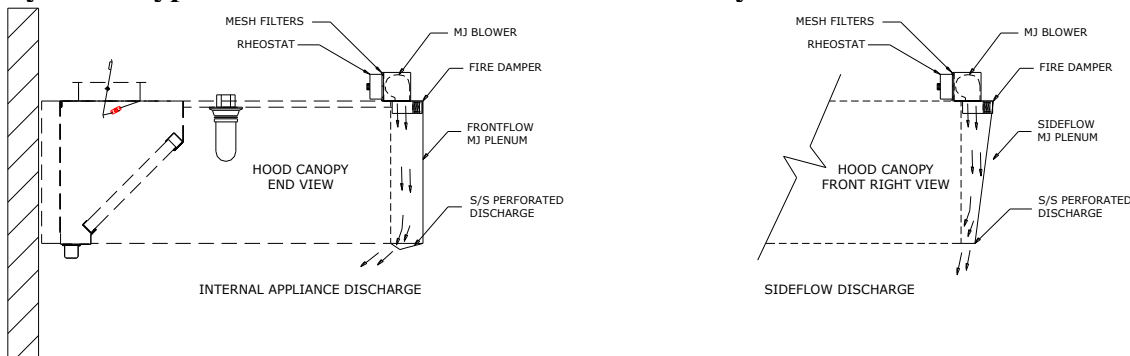

*Measuring MJGrill Appliance Region  
Figure 35*

### A. Measuring the Appliance Region

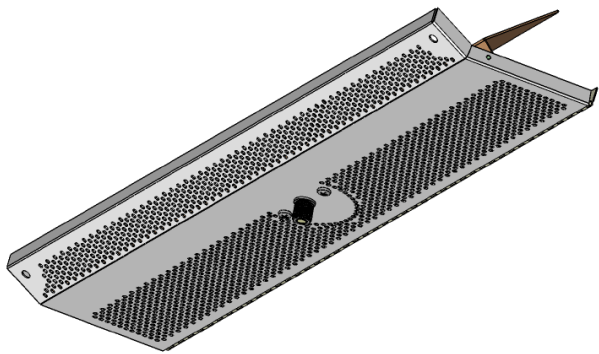

*MJGrill with Comfort Tuning Dial  
Figure 36*

The Appliance Region and Chef Region discharge is called the MJGrill. The MJGrill is manufactured as a single component shown on the left in Figure 28. The MJGrill includes the Appliance Region discharge, Chef Region discharge, and an adjustable Comfort Tuning Dial. The Comfort Tuning Dial proportions the amount of air to the Chef Region.

The Comfort Tuning Dial on the MJ Grill has two colored dots; red and blue. The Comfort Tuning Dial proportions the volume of air to the chef. Turning the Comfort Tuning Dial towards the red dot provides less air to the Chef Region and turning the Comfort Tuning Dial towards the blue dot provides more air to the Chef Region.



*Comfort Tuning Dial  
Figure 37*

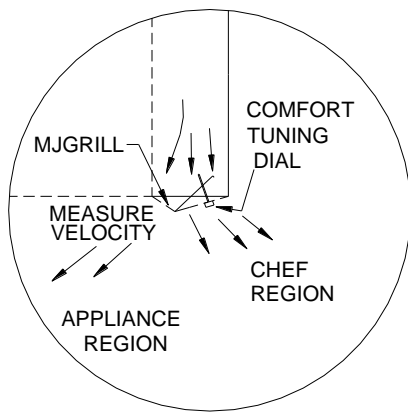

*Measuring the Appliance Region  
Figure 38*

To measure the Appliance Region air velocity rotate the Comfort Tuning Dial towards the red dot, counterclockwise to shut off air to the Chef Region. Now measure the velocity from the MJGrill perforated discharge towards the inside of the hood in the Appliance Region. The measurement can be made with a Hot Wire Anemometer or Vane Axial Velometer. The required air velocity is indicated below in Chart No. 7 Hood Appliances VS Appliance Region Face Velocity. If the velocity is too high or low the MJ Blower must be adjusted to increase or decrease the velocity to the Appliance Region.

## Hood Appliances VS Appliance Region Face Velocity

APPLIANCES	Hood Length (ft)	Discharge Velocity (fpm)	
		FRONT	SIDE FLOW
		Set point	Set point
<b>Heavy Appliances</b>	9 - 14	500	450
	6 - 9	500	450
	4 - 6	550	450
	Up to 4	550	450
<b>Medium and Light Appliances</b>	9 - 14	450	400
	6 - 9	450	400
	4 - 6	450	450
	Up to 4	450	450

*Chart No.7*

### B. Adjusting the MJ Blower to change the appliance region velocity

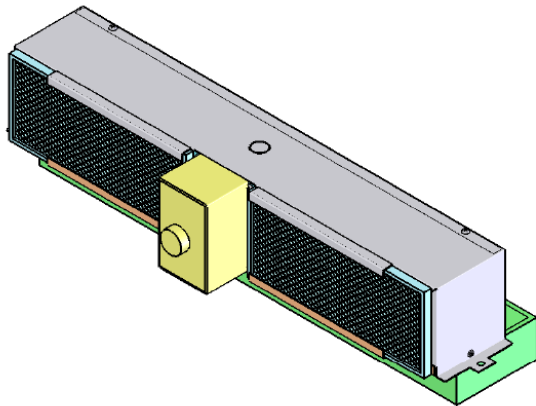

The MJ blower assembly is located on top of the MJ plenum. Each hood has one or more MJ Blower assemblies. To adjust the air flow of the MJ blower rotate the rheostat in the middle of the MJ blower assembly. Rotating the knob clockwise increases the air flow and rotating the knob counter clockwise decreases the amount of air into the plenum. Adjust the knob until the correct velocity is measured one the MJ Grill appliance discharge.

*Adjusting the MB Blade Threaded Rod  
Figure 39*

### C. Adjusting the air velocity to the Chef Region



The amount of air directed to the Chef Region is a personal decision. When commissioning an MJ hood system we recommend the following:

Heavy Appliances, Charbroilers, Woks: Rotate the Comfort Tuning Dial towards the blue dot three (3) rotations clockwise.

Medium Appliances, Griddles, and Ranges: Rotate the Comfort Tuning Dial towards the blue dot one (1) rotations clockwise.

Light Appliances, Ovens, and Kettles: Rotate the Comfort Tuning Dial towards the red dot to fully close the air to the Chef Region.

*Comfort Tuning Dial  
Figure 40*

**NOTE: Check to make sure that the Appliance Region velocity does not decrease below the required velocity after adjusting the Chef Region air with Comfort Tuning Dial.**