



KES Enviro

Maintenance Manual

KES Enviro Maintenance Manual Table of Contents

Introduction.....	1
The System.....	1
Control System: Water Wash Ventilator SB, SBA Panels.....	2
Control System: Water Wash Ventilator AP, MP Panels.....	4
Filter Hood or Dry Grease Extractor.....	5
Control Circuit.....	7
Setting the Day and Time.....	13
Setting the Weekday Fan “ON” and “OFF” Times.....	14
Setting Weekend Operation.....	15
Odor Spray Systems.....	15
Where to Purchase Filters.....	19
Replacement Filter Equivalents.....	19
Trouble Shooting.....	20
KES Maintenance Schedule.....	22
KES Enviro Start-Up Report.....	24
Filter Frequency Chart.....	26

KES OPERATIONS AND MAINTENANCE MANUAL

INTRODUCTION

The SPRING AIR SYSTEMS INC. kitchen Enviro system (KES), Exhaust Cleaning Assembly for Kitchen Exhaust Duct, "Enviro Unit" is ULC and UL listed for use in a commercial kitchen exhaust system. KES units are available in sizes ranging from 1,000 CFM to 40,000 CFM for indoor or outdoor applications.

The primary function of a KES Enviro unit is to filter the grease, lint and dust particles and remove the odor from the exhaust air.

The Underwriters' Laboratories of Canada Limited (ULC) listing allows the use of non-NFPA-96 exhaust ductwork after the exhaust air is discharged from the KES unit. In other words the discharge ductwork can be treated similar to standard HVAC ducting. Also after the kitchen exhaust air has been treated with the KES unit the exhaust can be discharged outdoors at low levels.

The Underwriters Laboratories Inc. (UL) listing allows the kitchen exhaust air to be discharge to atmosphere at low levels.

Prior to any installation the installer must seek approval from the authorities having jurisdiction.

THE SYSTEM

The grease-laden air rises from the cooking equipment into a UL or ULC exhaust hood. The exhaust hood removes some of the airborne grease particulate. Typically most micron and submicron particles escape

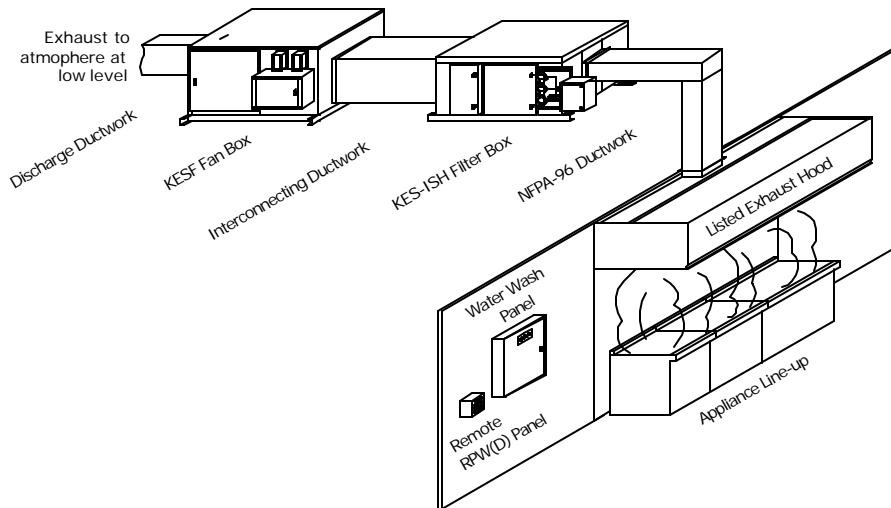

into the exhaust ductwork. The exhaust ducting is connected from the hood to the inlet of the KES Enviro unit. This exhaust ductwork must be supplied and installed in accordance with the NFPA-96 code.

*KES System Schematic
Figure 1*

Within the KES unit the exhaust air travels through three stages of particulate filters:

- 1Two (2) inches pleated - 30 percent ASHRAE 52-76 prefilters.
- 2Twenty-one (21) to twenty-two (22) inch bag - 90 percent ASHRAE 52-76 filters.
- 3Twelve (12) inches box - 95 percent DOP filters.

Once through the particulate filter sections the exhaust air enters the optional odor removal section. The odor section is only required when discharging cooking smells may be offensive. This section consists of two optional odor removal systems.

1. Odor Cells filled with activated alumina impregnated with potassium permanganate. The odor is controlled through a combination of sorption and the chemical modification of the gaseous contaminants. The odor media is non-toxic and non-flammable.
1. Odor spray solution. The odor is control by spraying an odor reducer into the exhaust air stream intermittently during the operation of the cooking systems.

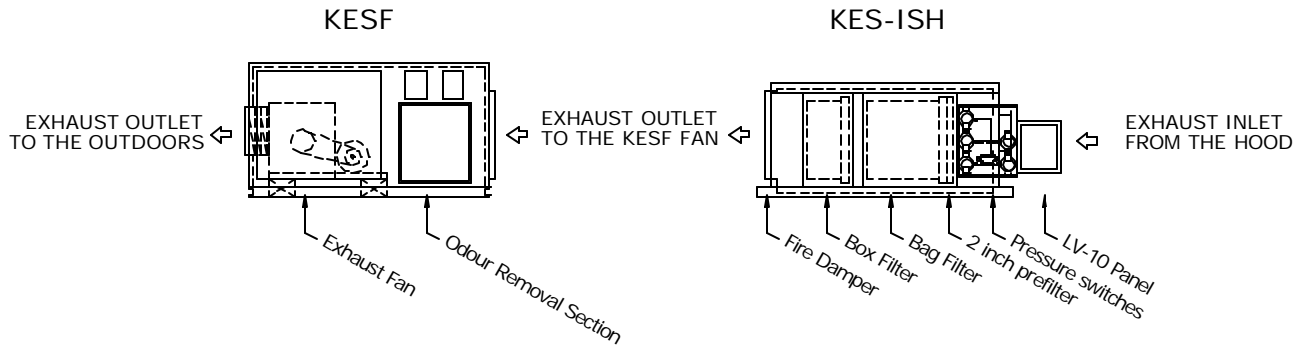

2.

*KES-ISH and KESF Enviro components
Figure 2*

The exhaust air is discharged from the KES unit through a single width, single inlet (SWSI) or double width, double inlet (DWDI) exhaust fan. The discharge ductwork transfers the exhaust air outdoors.

CONTROL SYSTEM

Water Wash Ventilator System: SB, SBA Panels

The KES unit off/on operation is controlled from the SB, or SBA water wash ventilator control panel. Power is fed to the RPW10 panel through terminals 1 & 4. When the fan selector switch on the water wash control panel closes a signal is sent through terminal 3 to the RPW10 panel to activate the KES unit.

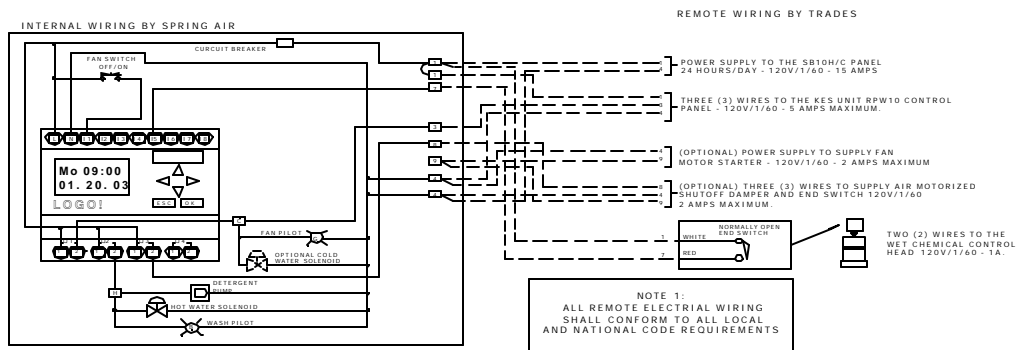

*Typical KES wiring to SB10C water wash panel
Figure 3*

The "NORMAL" operation pilot energizes on the RPW10 remote kitchen annunciation panel. After 30 seconds the RPW10 control circuit is activated. The RPW10 is a stainless steel panel located remote from the SB or SBA panel. See Figure 5 for RPW10 wiring and dimensions. The KES exhaust fan motor is energized through the terminals 5 & 4 to the LV10 J-Box located on the KESF fan section. See figure 11 for internal wiring of the LV10 J-box. See figure 3 or 5 for a SB water wash panel.

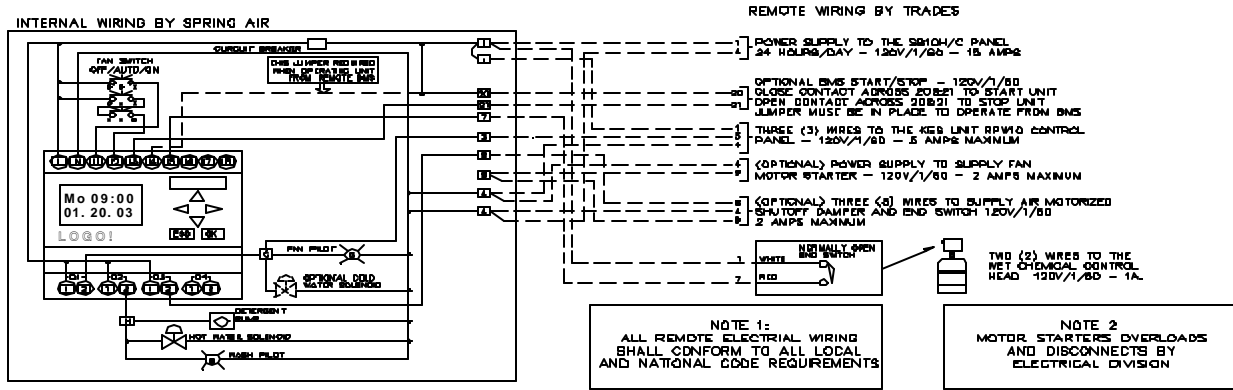

Typical KES wiring to SBA10C water wash panel
Figure 4

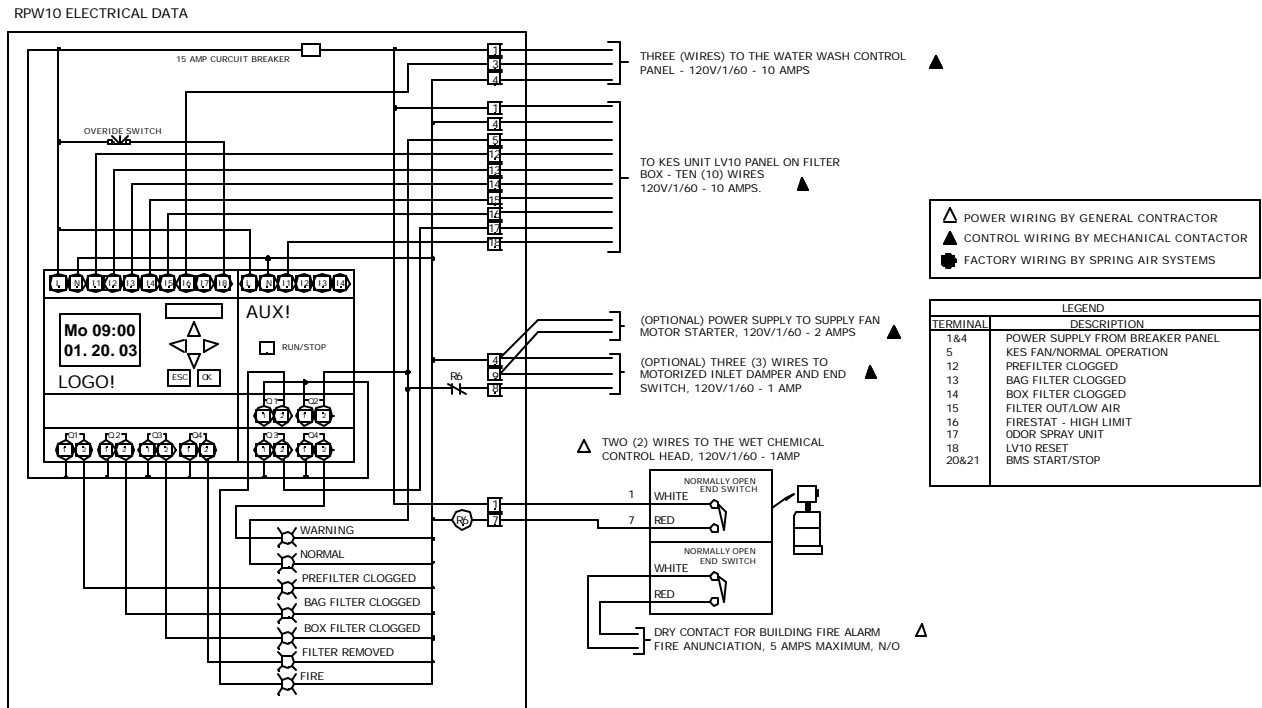

RPW10 Wiring Schematic
Figure 5

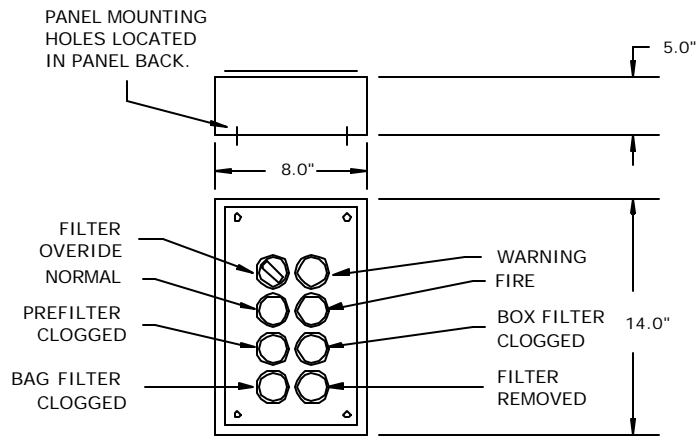

Remote RPW10 Panel Dimensions
Figure 6

Water Wash Ventilator System: AP, MP Panels

The KES unit off/on operation is controlled from the MP or AP water wash ventilator control panel. The fan selector switch on the water wash control panel closes and sends power through terminals 3 & 4 to the RPW10 remote panel to energize the exhaust fan through terminals 5 & 4 in the LV-10 J-Box. (The LV10 J-Box is mounted on the KES-ISH filter section).

The "NORMAL" operation pilot energizes on the RPW10. After 30 seconds the KES control circuit within the RPW10 remote panel is activated. See Figure 5 for RPW10 internal wiring. The exhaust fan motor is energized through the terminals 9 & 4 to the motor starter located on the KESF fan section. See figure 11 for internal wiring of LV10 J-Box with RPW10 remote panel.

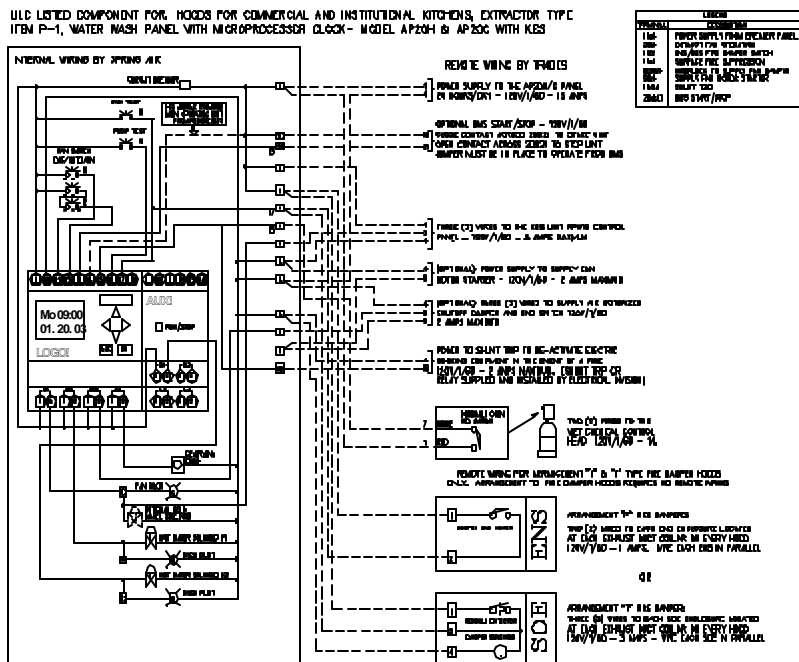

Typical KES wiring to AP20C water wash panel
Figure 7

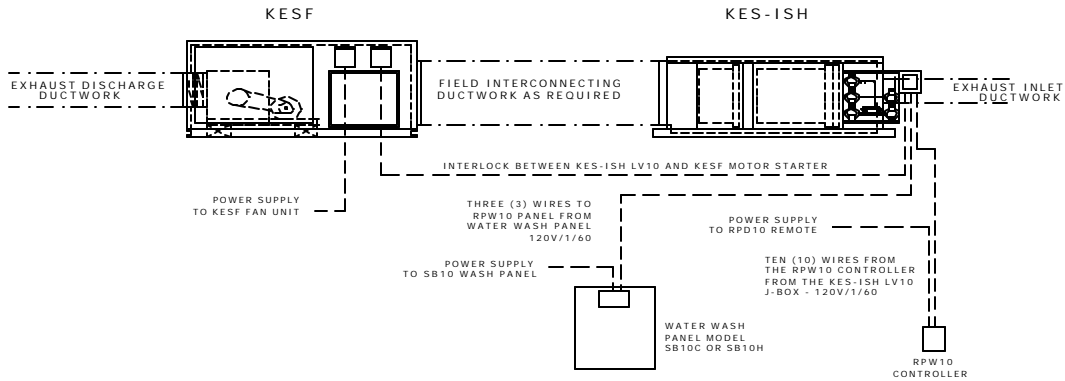

Remote wiring of KES Enviro units with Water Wash Hood and Panel
Figure 8

Filter Hood or Dry Grease Extractor: RPD10 Remote Panel

The KES unit off/on operation is controlled from RPD10 remote annunciation panel. The fan selector switch on the RPD10 remote panel closes and sends power through terminals 5 & 4 to the LV10 J-Box to energize the exhaust fan circuit. (The LV10 J-Box is mounted on the KES-ISH filter section). The "NORMAL" operation pilot on the RPD10 remote kitchen annunciation panel energizes and after 30 seconds the KES control circuit within the RPD10 remote panel is activated. The exhaust fan motor is energized through the terminals 5 & 4 to the motor starter. See figure 8 for the RPD10 remote panel wiring and figure 9 for dimensions.

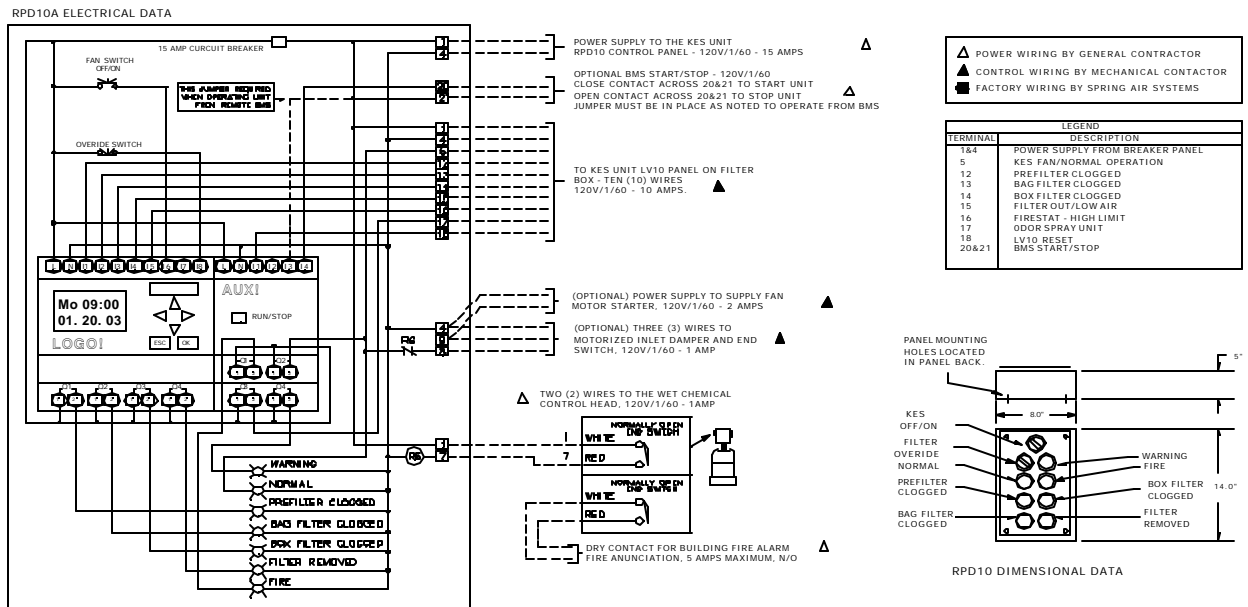

RPD10 Wiring Schematic
Figure 9

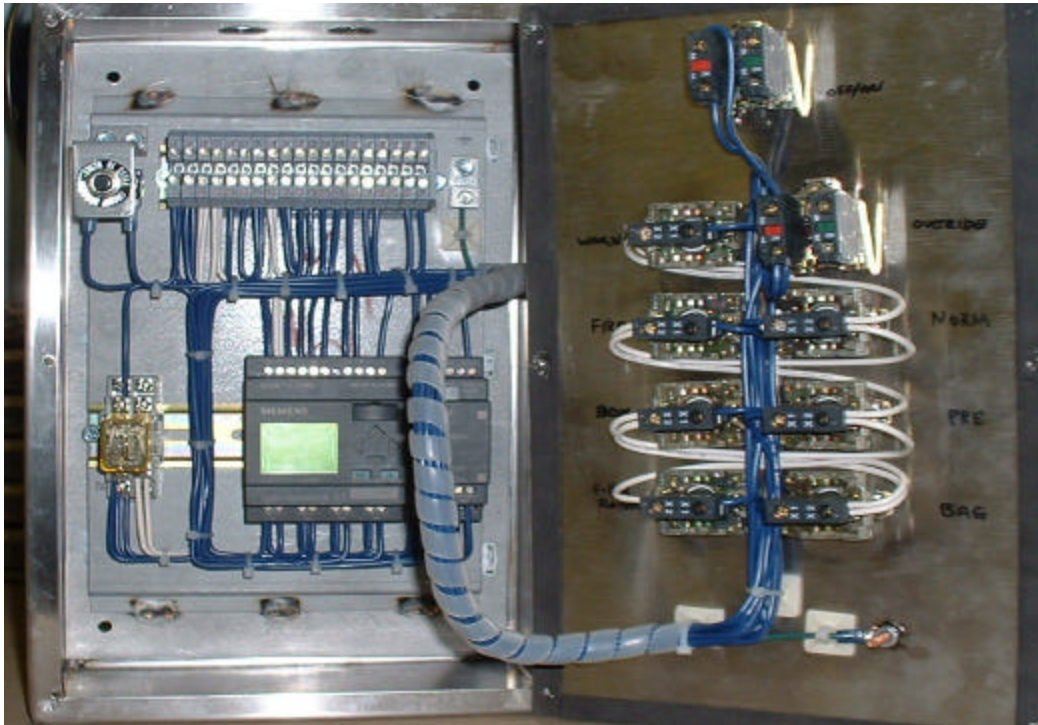

RPD10 Internal Wiring
Figure 10

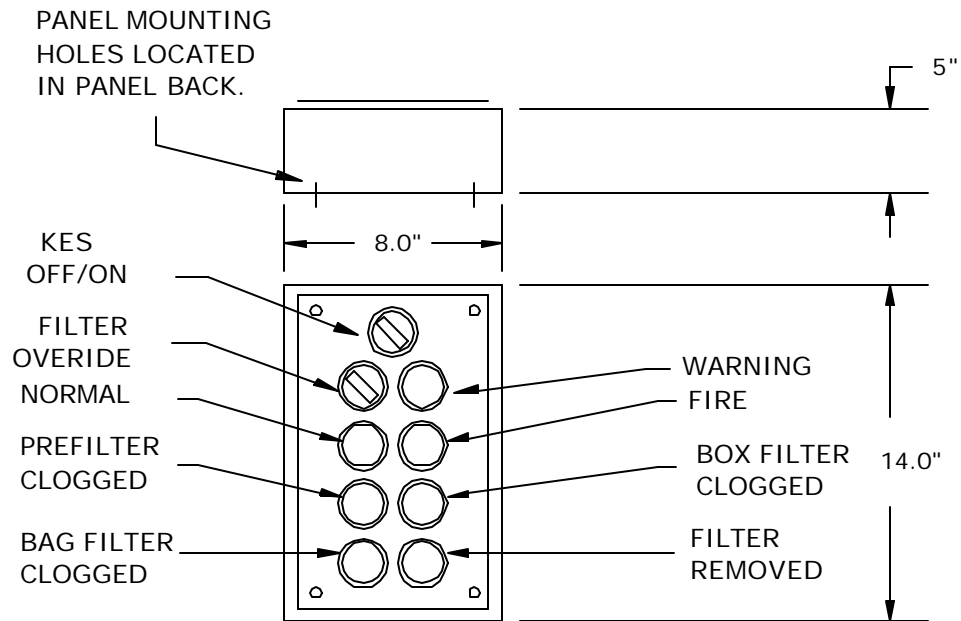

RPD10 Remote Panel Dimensions
Figure 11

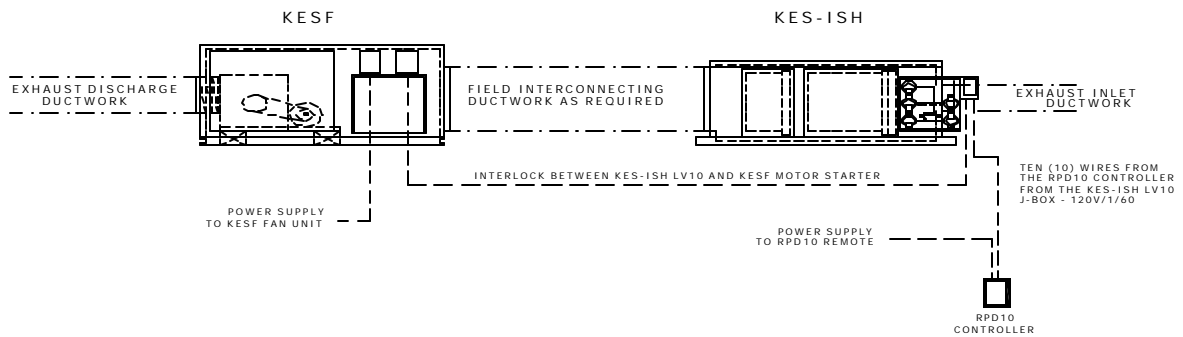

Remote wiring of KES Enviro units with Dry Hood
Figure 12

CONTROL CIRCUIT

Filter Clogged:

During normal operation of the KES unit three-filter stages collect grease, dust, and lint particulate. The type of cooking equipment and the hours of operation determines the useful life of the individual filters.

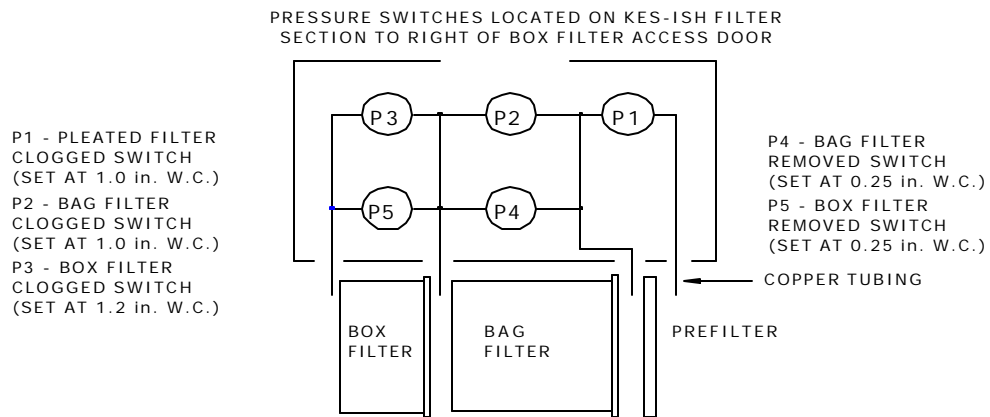

Pressure Switch Locations
Figure 13

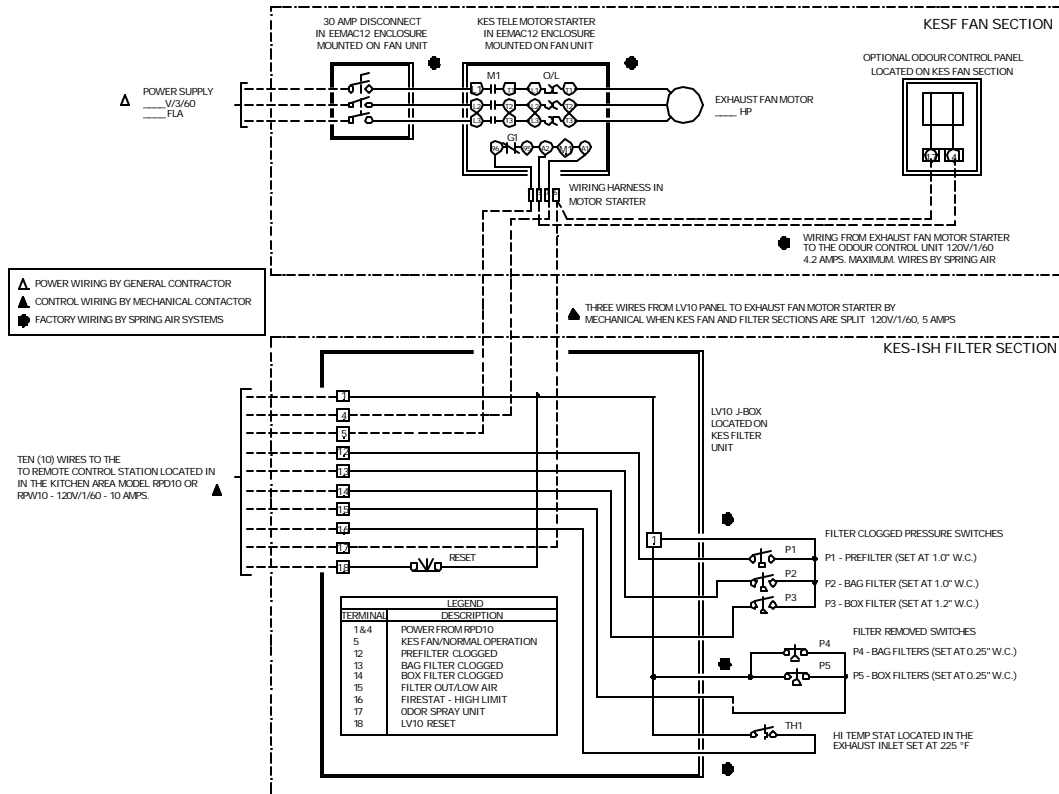

Typical indoor KES, motor starter, LV10 J-Box with odor spray wiring schematic
Figure 14

Pressure switches have been installed to determine when the filters are totally used and must be replaced. As the filter reaches the grease loading capacity the static pressure across each filter increases. When the maximum static pressure is reached the pressure switch is activated. The exhaust fan shuts off, the "NORMAL" pilot energizes, and the kitchen remote panel annunciates a filter-clogged condition. (The remote panel indicates which stage of filters has clogged; PREFILTER, BAG FILTER, or BOX FILTER.) In addition the screen of the LOGO controller in the RPD10 or RPW10 has a text message also indicating which filter is clogged.

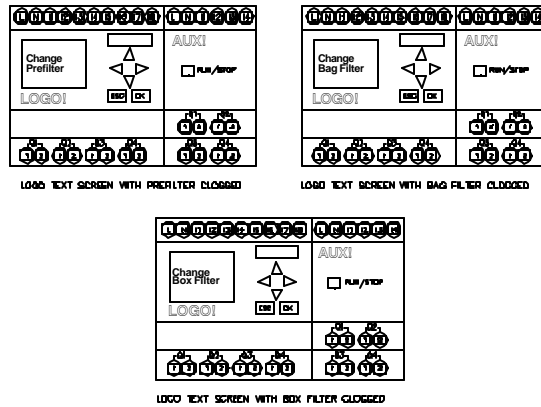

RPD10 or RPW10 LOGO controller indicating Box Filter clogged text messages
Figure 15

The clogged filter must be replaced and the system reset to resume normal operation. If this condition occurs during normally operating hours rotate the OVERRIDE selector switch and the fan will come back on. The systems can run in the OVERRIDE position for about 4 hours. (See the section the OVERRIDE switch) If the system runs longer than 4 hours the fan will shut down. The filters must be changed and the system reset. It is recommended that the filters be changed prior to the filter clogged light energizing. A filter usage chart is attached to record when the filters are being changed. Using this chart a regular maintenance schedule can be set up to ensure constant uninterrupted operation of the commercial kitchen.

Filter Removed:

Should the bag or box filters be removed during normal operation the KES unit is automatically shut down. A pressure switch across the bag filters and box filters monitors a minimum pressure drop of 0.25" W.C. When the filter is removed the pressure differential falls and the pressure switch is activated. The exhaust fan shuts off, the "FILTER REMOVED" pilot light on the RPD10 or RPW10 energizes and the screen of the LOGO controller in the RPD10 or RPW10 has a text message indicating "FILTER REMOVED/LOW EXHAUST. To resume normal operation the filter must be replaced and the system reset. (See the section the OVERRIDE switch)

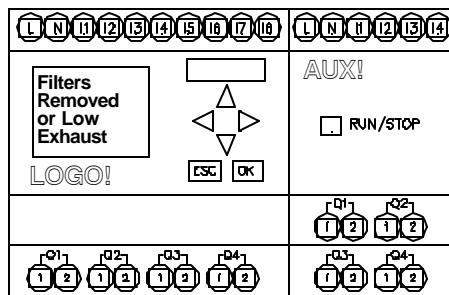

*RPD10 or RPW10 LOGO controller indicating filter removed text message
Figure 16*

Fire:

In the event of a high temperature in the ductwork leading to the KES unit or within the KES unit a firestat located at the inlet of the KES filter section is activated. When the exhaust air reaches 160 F the firestat is energized. The exhaust fan shuts off, the "NORMAL" pilot goes off, and a "FIRE" pilot energizes on the remote RPD10 or RPW10 panel. Should the exhaust temperature continue to rise the fusible link melts and closes the fire damper in the exhaust discharge of the KES filter section. This fire damper is always located between the fan and filter section. The fire damper fusible link is rated at 165 F. Shut off all cooking equipment and notify the fire department. To resume normal operation, replace the fusible link and reset the system. An authorized SPRING AIR SYSTEM INC. service technician should be called to inspect the unit.

Override Switch: (located on RPW10 or RPD10 panel)

In the event that the filter clogged annunciation shuts off the KES unit during a peak cooking time rotate the OVERRIDE SWITCH located on the RPW10 panel clockwise. The WARNING pilot light will energize and the FILTER CLOGGED and NORMAL lights will turn off. This is a temporary override to allow for the cooking equipment to be shut off prior to changing the filters. The systems can run in the OVERRIDE position for 4 hours. If the system runs longer than 4 hours the fan will shut down. The filters must be changed and the system reset. It is recommended that the filters be changed prior to the filter clogged light energizing. A filter usage chart is attached to record when the filters are being changed. Using this chart a regular maintenance schedule can be set up to ensure constant uninterrupted operation of the commercial kitchen.

Once the dirty filter has been replaced rotate the OVERRIDE SWITCH to counter clock wise to resume normal operation.

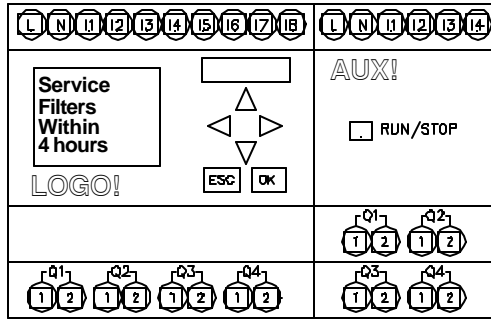

*RPD10 or RPW10 LOGO with Override selector in on position
Figure 17*

System Reset:

After any of the safety circuit annunciation, the system must be reset. The system is reset by toggling the "RESET" switch in the LV10 J-box, or switching the OVERRIDE SWITCH on the RPW10 or RPD10, or turning the fan selector switch to the "OFF" and then to the "ON" position.



*Logo Processor
Figure 18*



*RPD10 Face Plate
Figure 19*



*RPW10 Face Plate
Figure 20*

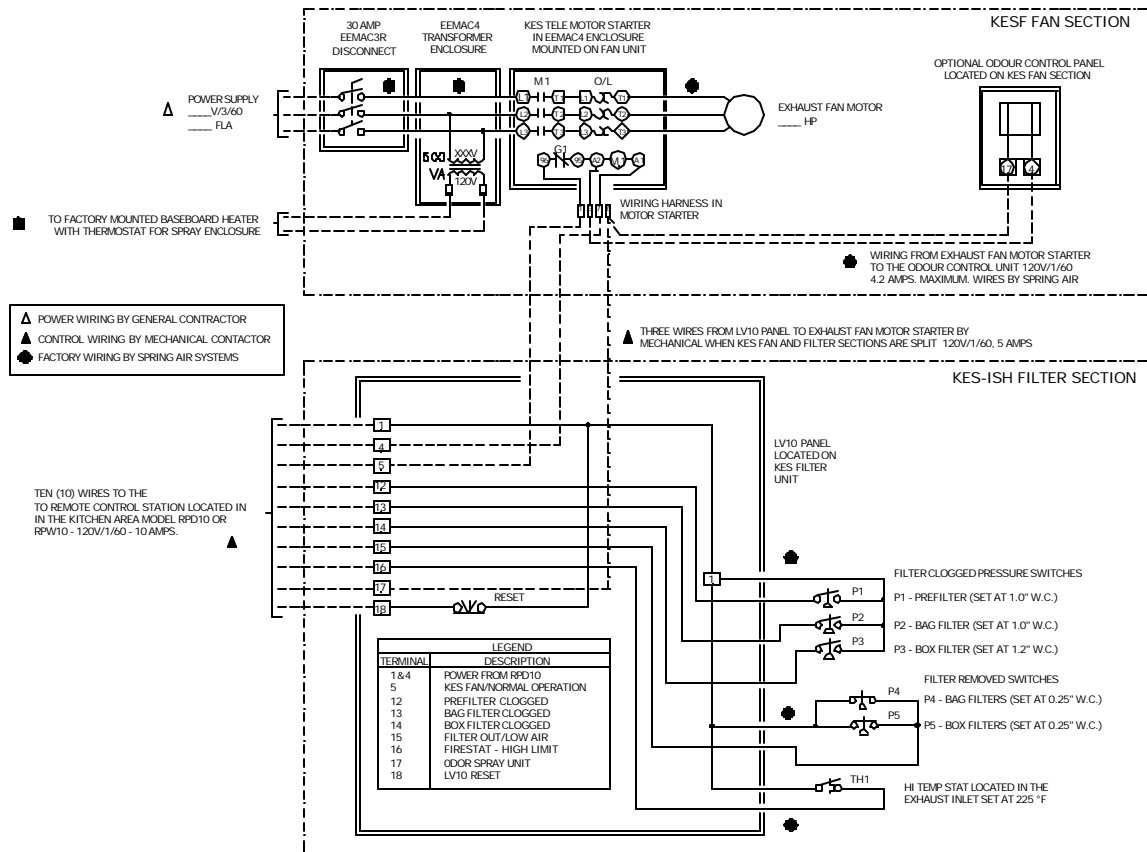

Wiring diagram for Outdoor KES, motor starter, LV10 J-Box, and odor unit
 Figure 21

Setting the Day and Time

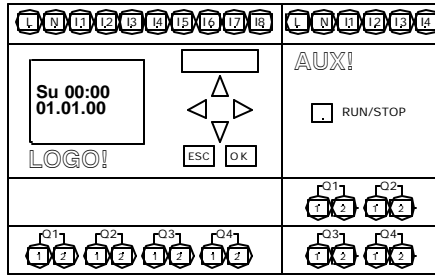

- | | |
|--|---|
| Su 00:00
01.01.00 | <p>1. When power is first applied to the RPD10 panel the following display will blink. If the SERVICE FILTERS WITHIN 4 HOURS displays instead the OVERRIDE switch is on. Just rotate the switch and the correct display will blink.</p> |
| >Stop
Set Parma
Set Clock
Prg Name | <p>2. Press OK and the following screen will appear.</p> |
| Stop
Set Parma
>Set Clock
Prg Name | <p>3. Press ▽ twice.</p> |
| Set Clock
■Su 00:00
MM.DD.YY
01. 01. 00 | <p>4. Press OK and the following screen will appear.</p> |
| Set Clock
■Th 00:00
MM.DD.YY
01. 01. 00 | <p>5. To change the day press △ until the correct day appears.</p> |
| Set Clock
Th 00:00
MM.DD.YY
01. 01. 00 | <p>6. To change the time press ▷ once. The hour will be highlighted. Press △ or ▽ until the correct hour appears. Press ▷ to move to minutes. Adjust the minutes by pressing △ or ▽ until correct minutes appears.</p> |
| Set Clock
Su 06:16
MM.DD.YY
01. 01. 00 | <p>7. To change the date press ▷ again. The month will be highlighted. Press △ or ▽ until the correct month appears. Press ▷ to move to day. Adjust the day by pressing △ or ▽ until correct day appear. Press ▷ to move to year. Adjust the year by pressing △ or ▽ until correct year appears.</p> |
| Set Clock
Su 06:16
MM.DD.YY
01. 06. 03 | <p>8. You have finished setting the clock.</p> |
| Su 06:16
01. 06. 03 | <p>7. Press OK and ESC to return to the operating screen.</p> |

*Setting the clock on RPD10A automatic panels
Figure 22*

Setting the Weekend Fan "ON" and "OFF" times

<p>Su 06:16 01. 06. 03</p>	<p>1. Press <input type="button" value="ESC"/></p>
<p>>Stop >Set Parma >Set Clock >Prg Name</p>	<p>2. Press <input type="button" value="▽"/> once.</p>
<p>Stop >Set Parma >Set Clock >Prg Name</p>	<p>3. Press <input type="button" value="OK"/></p>
<p>B04: No1 D =MTWTFSS On = 06: 00 Off = 23: 00</p>	<p>4. Press <input type="button" value="△"/> until the B04: No1 timer appears. This is the time setting for start and stop each weekday.</p>
<p>B04: No1 D =MTWTFSS On = 06: 00 Off = 23: 00</p>	<p>5. The clock has been factory set to turn the fan on at 6:00 a.m. and off at 23:00 hours or 11:00 p.m.</p>
<p>B04: No1 D = <input type="checkbox"/>TWTFSS On = 06: 00 Off = 23: 00</p>	<p>6. To change the above settings press <input type="button" value="OK"/> The cursor will move to M = Monday.</p>
<p>B04: No1 D = MTWTF-S On = 06: 00 Off = 23: 00</p>	<p>7. Press <input type="button" value="△"/> to remove Monday from the weekly schedule. The - dash indicates the fan will not start automatically any given day.</p>
<p>B04: No1 D = - TWTF- - On = 06: 00 Off = 23: 00</p>	<p>8. Press <input type="button" value="▷"/> to move to the next day of the week. Press <input type="button" value="△"/> each time the fan is not required to operate on that given day. The screen on the left indicates the fan will not automatically operate on Monday, Saturday or Sunday.</p>
<p>B04: No1 D = - TWTF- - On = <input type="checkbox"/>6: 00 Off = 23: 00</p>	<p>9. Press <input type="button" value="▷"/> to move to the hour that the fan will start in the morning. Press <input type="button" value="▷"/> to change the hour you want the fan to start in each morning. Press <input type="button" value="▷"/> to move to the minute the the fan will start in the morning. Press <input type="button" value="△"/> to change the minutes.</p>
<p>B04: No1 D = - TWTF- - On = 06: 30 Off = <input type="checkbox"/>3: 00</p>	<p>10. Press <input type="button" value="▷"/> to move to the hour that the fan will stop in the evening. Press <input type="button" value="▷"/> to change the hour you want the fan to stop each evening. Press <input type="button" value="▷"/> to move to the minute the fan stop in the evening. Press <input type="button" value="△"/> to change the minutes.</p>
<p>B04: No1 D = MTWTF- - On = 06: 30 Off = 22: 30</p>	<p>11. Press <input type="button" value="OK"/></p>
<p>Su 06:16 01. 06. 03</p>	<p>12. If your selection is complete press <input type="button" value="ESC"/> and <input type="button" value="ESC"/> to return to the operating screen. You have completed programming one weekly fan "On" and "Off" cycling. If you wish to program a second (Weekend Operation) or third weekly setting go the the section "Setting Weekend Operation"</p>

Setting the Week Day Fan On and Off Timers on RPD10A automatic panels
Figure 23

Setting Weekend Operation

- | | |
|---|--|
| <p>Su 06:16
01. 06. 03</p> | 1. Press <input type="button" value="ESC"/> |
| <p>>Stop
Set Parma
Set Clock
Prg Name</p> | 2. Press <input type="button" value="▽"/> once. |
| <p>Stop
>Set Parma
Set Clock
Prg Name</p> | 3. Press <input type="button" value="OK"/> |
| <p>B04: No2
D = -:-:-:-
On = -:-:-:-
Off = -:-:-:-</p> | 4. Press <input type="button" value="△"/> until the B04: No1 timer appears. This is the time setting for start and stop each weekday. |
| <p>B04: No2
D = ■-:-:-:-
On = -:-:-:-
Off = -:-:-:-</p> | 5. Press <input type="button" value="OK"/> to program the weekend operation. |
| <p>B04: No2
D = -:-:-:-SS
On = -:-:-:-
Off = -:-:-:-</p> | 6. Press <input type="button" value="▷"/> five times to move to Saturday. Press <input type="button" value="△"/> to turn fan on Saturday. Press <input type="button" value="▷"/> once to move to Sunday. Press <input type="button" value="△"/> to turn fan on Sunday. |
| <p>B04: No2
D = -:-:-:-SS
On = ■-:-:-:-
Off = -:-:-:-</p> | 7. Press <input type="button" value="▷"/> to move to the hour that the fan will start in the morning. Press <input type="button" value="▷"/> to change the hour you want the fan to start in each morning. Press <input type="button" value="▷"/> to move to the minute the the fan will start in the morning. Press <input type="button" value="△"/> to change the minutes. |
| <p>B04: No2
D = -:-:-:-SS
On = 10:00
Off = ■-:-:-:-</p> | 8. Press <input type="button" value="▷"/> to move to the hour that the fan will stop in the evening. Press <input type="button" value="▷"/> to change the hour you want the fan to stop each evening. Press <input type="button" value="▷"/> to move to the minute the fan stop in the evening. Press <input type="button" value="△"/> to change the minutes. |
| <p>B04: No2
D = -:-:-:-SS
On = 10:00
Off = 23:30</p> | 9. Press <input type="button" value="OK"/> If your selection is complete press <input type="button" value="ESC"/> and <input type="button" value="ESC"/> to return the operating screen. |
| <p>Su 06:16
01. 06. 03</p> | 10. You have completed programming weekend fan "On" and "Off" cycling. |

*Setting the and Weekend Fan On and Off Timers on RPD10A automatic panels
Figure 24*

ODOR SPRAY SYSTEM

Operating and Maintenance

The Spring Air Systems Inc. odor spray unit has a one-year warranty from startup. The two timers, cycle timer B01, and spray timer B02, are factory set (5 minute cycle and 2 second spray) and then adjusted during startup to the odor reducing intensity required for the application. The B01 cycle timer is generally set between 5 to 10 minutes. The B02 spray timer is generally set between 2 to 60 seconds.

How does it Work?

The odor spray setting is a qualitative measurement. The spray timers are field set to provide adequate odor reduction for the installation. This is completely subject to what a particular person feel is an acceptable discharge odor.

During the spray timer activation the combination air compressor and air-atomizing nozzle injects a volume of odor solution into the exhaust discharge. This solution is carried along the discharge duct and vented to atmosphere. The spray solution chemically activates with the kitchen exhaust air to reduce the kitchen exhaust odors. As the solution is carried down the duct some adheres to the duct walls. We will call this the spray residue. During the cycle time when the spray is not activated this spray residue continues the odor reducing process as the exhaust air passes. Therefore installation with longer discharge ducts can normally use a longer cycle time because there will be more spray residue. A shorter run of discharge duct usually results in shorter cycle time.

- A. When adjusting the timers the object is to use as little spray solution as possible to provide adequate odor reduction:
1. First adjust the spray cycle, B01 timer.
 2. Reduce this setting by $\frac{1}{2}$ of the original cycle setting and check the operation. If $\frac{1}{2}$ proves adequate, increase the cycle back to $\frac{3}{4}$ of the original cycle setting. If this is adequate increase to $\frac{7}{8}$ of the original setting and so forth.
 3. If reducing the setting by $\frac{1}{2}$ is not adequate decrease the cycle to $\frac{1}{4}$ of the original setting. If this is not adequate adjust the spray timer B02.
 - a. Increase the spray time B02 in increments of 5 seconds. After each 5 second increase evaluate the quality of the exhaust discharge air to determine if it is acceptable to the user.
 - b. When the spray timer setting equals the cycle timer settings the spray will be continuous. The maximum setting of B02 should not exceed the cycle timer B01.

The odor spray bottle must be changed regularly depending on the length of time set on timers B01 and B02. The odor spray line from the spray bottle to the spray nozzle must be cleaned every 6 months in a water and detergent mixture. The compressed air gauge should read between 10 and 15 psi. When the air gauge is reading below 10 psi clean out the compressed air line. If the pressure is still low proceed to the next step compressor maintenance.

When there is odor in adjoining floors or office spaces

A kitchen located in the interior of an office building must be very negative to keep the kitchen odor within the kitchen. We recommend the kitchen be a minimum 20% negative. The fresh air supply is 80% of the total exhaust air from the kitchen space. When there is odor in adjoining spaces check the following.

1. The kitchen is not negative enough to keep the smell of the kitchen in the kitchen. If this is the case the odor is usually present all the time, even when there is no cooking. Reduce the amount of fresh air to the kitchen by adjusting the supply fan volume.
2. The kitchen may be connected to the same building A/C unit as the rest of the floor. If this is the case the return air grilles in the kitchen draws the kitchen odor to the main A/C unit and disperses the odor throughout the floor. The main A/C return must be blocked from the kitchen and put on a separate A/C unit.
3. The floor above the kitchen have odor. There are three possibilities.
 - a. The exhaust shaft is not sealed and the kitchen exhaust is leaking out onto the floors above the kitchen. Either adjust the amount of odor spray per section "A" above or install

an exhaust fan on the roof to draw the kitchen exhaust to the roof and maintain a negative pressure in the discharge duct.

- b. The odor may escape when the kitchen is not operating during the night. After the kitchen is shut off kitchen odor may migrate up the exhaust duct and leak out into the adjoining floors. This can be solved by operating the kitchen exhaust for a couple hours after the cooking has stopped for the day and starting the kitchen exhaust fan an hour before cooking starts in the morning.

Setting the cycle and spray times

Su 06:16 01. 06. 03	1. Press ESC
>Stop Set Parma Set Clock Prg Name	2. Press ▽ once.
Stop >Set Parma Set Clock Prg Name	3. Press OK
B01: T T = 05:00m Ta = 05:00m	4. Press △ until the B01 timer appears. This is the cycle timer or the time period between sprays.
B01: T T = 5 :00m Ta = 00:00m	5. To change the cycle time press OK
B01: T T = 05 :00m Ta = 00:00m	6. The first two digits are minutes and the two digits to the right are seconds. Press △ to change the cycle length in minutes. Press ▷ to move to the cycle length in seconds. Press △ to change the seconds.
B01: T T = 04:30m Ta = 00:00m	7. Press OK if the cycle time is correct.
B02: T T = 03:00s Ta = 00:00m	8. Press △ until the B02 timer appears. This is the spray timer or the length of the odor sprays.
B02: T T = 3 :00s Ta = 00:00s	9. To change spray time press OK
B02: T T = 03 :00s Ta = 00:00s	10. The first two digits are seconds and the two digits to the right are 0.1 and 0.01 seconds. Press △ to change the spray in seconds. Press ▷ to move to the spray time in fractions of a second. Press △ to change the 0.1 and 0.01 seconds.
B02: T T = 02:30s Ta = 00:00s	11. Press OK if the cycle time is correct.
Su 06:16 01. 06. 03	12. Press ESC and ESC to return to the operating screen.

*Setting the Cycle and Spray Timer
Figure 25*

Compressor Maintenance

Do not, at any time lubricate any of the parts with oil, grease, or petroleum products nor clean with acids, caustics or chlorinated solvents. Be very careful to keep the diaphragm from contacting any petroleum product of hydrocarbons. It can affect the service life of the pump.

To clean or replace the filters and/or rubber gasket, remove the five screws in the top of the unit. The filters and gaskets are located beneath this top plate. Remove the filters and wash then in a solvent and/or blow off with air and replace. The gasket may be cleaned with water. Replace the filters in proper position and replace the gasket. Note that the gasket and top plate will fit in one position only.

To replace the diaphragm, remove the socket cap screws from the head of the pump. The diaphragm is held in place by two Philip head screws. Remove screws, retainer plate, and diaphragm. The diaphragm will fit in any position on the connecting rod. Replace the plate and the two Phillips head screws. Torque to 30 inch-pounds on DOA and DAA.

Caution: Do not raise any burrs or nicks on the heads of these screws. These burrs could cause damage to the inlet valve.

For replacing the inlet and outlet valve, remove the slotted machine screw that holds each valve in place. The stainless steel inlet and outlet valves are interchangeable. Clean them with water. When replacing the outlet valve, place the new valve in location and note there is a retaining bar near the machine screw hole. This retaining bar holds the valve in position. When replacing the inlet valve, note that the valve holder is marked with an X in one corner. This X should be in the lower right hand corner toward the inlet of the air chamber. Replace the head and tighten the socket head screws to 90-100 inch-pounds or torque on DOA and DAA.

WARNING -
The motor is thermally protected and can automatically restart when the protector resets. ALWAYS disconnect KES fan power source before servicing.

Do not attempt to replace the connecting rod or motor bearings. If after cleaning the unit and/or installing a new service kit, the unit still does not operate properly, contact your representative, the factory, or return the pump to one of our authorized Service Centers.

IF YOUR PUMP IS EQUIPPED WITH PLASTIC PLUGS IN THE EXHAUST AND/OR INTAKE POTS, REMOVE BEFORE STARTING THE UNIT

Wiring Information

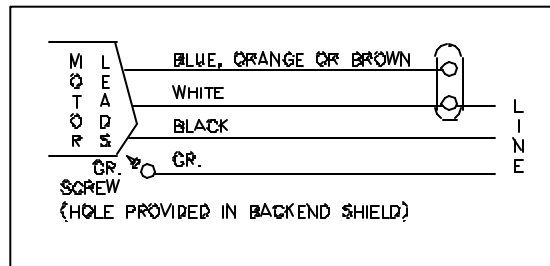

For any permanent split capacitor motor, which has four (4) leads is as follows:
Brown leads to capacitor.
Black-leads to Power Source.

For any permanent split capacitor for DOA & DAA motor, which has three (3) leads is as follows:

IMPORTANT NOTICE:

DO NOT AT ANY TIME ATTEMPT TO REMOVE THE CONNECTING ROD OR COMPLETELY DISASSEMBLE THE PUMP. IF IT DOES NOT GIVE YOU THE PROPER SERVICE EVEN AFTER INSTALLING A NEW SERVICE KIT, PLEASE RETURN IT TO ONE OF THE AUTHORIZED SERVICE CENTERS

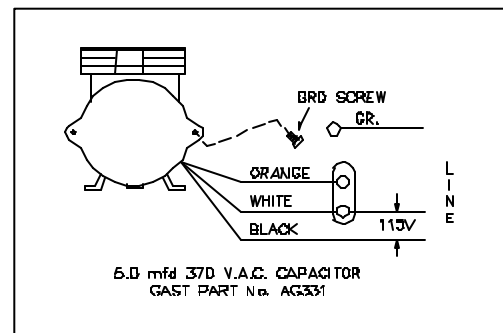

WHERE TO PURCHASE FILTERS:

Spring Air Systems Inc.

1388 Cornwall Rd., Oakville Ont., L6J 7W5
(905) 338-2999

Airguard Industries

125 Buttermill Rd., Concord, Ontario, L4K 3X5
905-669-9876

Airguard Corp.

4806 Strong Rd., Crystal Lake, IL, 60014
888-324-5665

Camfil Farr Filters

67 Steelecase Rd. W., Markham Ont., L3R 2M4
(905) 415-3030

Camfil Farr

2201 Park Place, El Segundo, CA, 90245
310-727-6300

RECOMMENDATION

TO ENSURE TROUBLE FREE OPERATION FOR YOUR KITCHEN EXHAUST SYSTEM A PROPER PREVENTATIVE MAINTENANCE PROGRAM IS A NECESSITY.

SPRING AIR SYSTEMS RECOMMENDS THAT A YEARLY SERVICE CONTRACT BE SET UP WITH A REPUTABLE SERVICE ORGANIZATION. THIS WILL REDUCE UNEXPECTED DOWN TIME TO A MINIMUM.

REPLACEMENT FILTER EQUIVALENTS

PREFILTERS: 30% ASHRAE 52-76 - ULC Class II

Airguard: 24" x 24" x 2" - DP40 Class II
12" x 24" x 2" - DP40 Class II

American Air Filter:

24" x 24" x 2" - AM-AIR Class II
12" x 24" x 2" - AM-AIR Class II

Farr Filters: 24" x 24" x 2" - 30% ASHRAE 52-76 Class II
12" x 24" x 2" - 30% ASHRAE 52-76 Class II

BAG FILTERS: 90 - 95% ASHRAE 52 - 76 - ULC Class II

Airguard: 24" x 24" x 22" - V9-4M Class II
12" x 24" x 22" - V9-4M Class II

American Air Filter:

24" x 24" x 21" - DRI-PAK - Class II
12" x 24" x 21" - DRI-PAK - Class II

Farr Filters: 24" x 24" x 22" - 90% ASHRAE 52-76 Class II
12" x 24" x 22" - 90% ASHRAE 52-76 Class II

BOX FILTERS: 95% DOP/99% ASHRAE 52-76 ULC Class II

Airguard: 24" x 24" x 12" - VMB- 904 Class II
12" x 24" x 12" - VMB-904 Class II

American Air Filter:

24" x 24" x 12" - BIOCELL Class II
12" x 24" x 12" - BIOCELL Class II

Farr Filter:

24" x 24" x 12" - 6 pocket - 95% DOP Class II
12" x 24" x 12" - 6 pocket - 95% DOP Class II

ODOR MEDIA: 1/8" Activated alumina pellets impregnated with potassium permanganate.

Airguard: Barneby-Cheney CP-2

American Air Filter:

Permasorb

Farr Filters:

Unisorb.

Odor Spray: Spring Fresh, Spring Air Systems

TROUBLE SHOOTING

I. Exhaust fan does not run.

Reset the system once. Press the reset button in the LV10 J-Box or turn the fan selector switch to "OFF" and "ON". Observe the sequence that follows.

1.The fan does not start and there is no indication on remote panel.

- a)Check power from the breaker to the RPD10.
- b)Check the three wiring connection from the wash panel to the RPW10 panel.

2.The fan does not start but the green normal pilot energizes for 30 seconds goes out and "Filter removed" pilot energizes.

- a)Check wiring between KES filter box LV10 J-box terminals 5 & 4 and the KESF fan motor starter.
- b)Check wiring between the RPD10 or RPW10 remote and the KES-ISH LV10 J-Box
- c)Reset the exhaust fan overload in the exhaust fan motor starter on the KESF fan section.
- d)Check three phase power to the KESF fan section disconnect.
- e)Check if exhaust duct access door is open between the KES filter section and hood.
- f)Check that all filters on in place.
- g)Check if the prefilter or box filter access door on the KES unit is open
- h)Check the Filter Removed pressure switch. The switch must make and close after 30 seconds of operation. Adjust the pressure setting or replace switch.
- i)If all the filters are in place check if pressure tips on the end of the pressure switch manifolds are plugged. There is a pressure tip in front and behind each filter.
- j)Measure Exhaust air volume. If low increase fan RPM to within FLA of fan motor
- k)Check KESF exhaust fan motor starter coil. Replace or repair.
- l)Check KESF fan belts if loose or broken.
- m)Check KESF exhaust fan motor. Replace or repair.

3.The exhaust fan runs for 30 seconds then shuts off and one of the Filter Clogged pilots energizes.

- a.Check the wiring from the LV10-J-Box to the pressure switch
- b.Check pressure switch operation P1, P2 & P3. These switches should remain open after 30 seconds operation. Calibrate the pressure setting or replaced switch.
- c.Check the wiring between the RPD10 or RPW10 panel and the LV10 J-Box.

II. Low Exhaust Air

1.Exhaust fan is running but exhaust air is low.

- a)Check if fan belts are slipping. Tighten if necessary.
- b)Check if fusible link fire damper has closed in the KES filter section. Replace fusible link.
- c)Check if filters are dirty but have not activated the "Filter Clogged" pilot. Replace dirty filters.
- d)Check for correct fan rotation.

III. Filter Clogged Pilot On.

1. Filter clogged pilot indicates which filter section has plugged. Replace filter and reset system.

IV. Filter Removed Pilot On.

1. A filter has been removed or access door left open. Replace if necessary.

V. Fire Pilot On.

1. The fire stat in the KES filter section exhaust outlet has activated and shut the KES system down. If a fire is not present check calibration of firestat TH1. Firestat should be set at 160F.

If operation problems persist check the individual the connection between the RPD10 or RPW10 panel and the LV10 J-Box. If problems still exist contact an authorized SPRING AIR SYSTEMS service technician.

KES MAINTENANCE SCHEDULE

Every two weeks:

1. Inspect the prefilters. Replace if necessary. It is important to maintain clean prefilters. Replacing the inexpensive prefilters often extends the life of the bag and box filters and reduces unnecessary down time due to clogged filter shutdowns. *The RPD or RPW annunciation panel will indicate separately when the “prefilter”, “bag” and “box” filters are clogged. When this occurs the unit shuts down. Rotate the override switch to energize the system for about 4 hours. This provides time to change the filters after the day of cooking. This is a final dirty filter warning. The filter life of all the filters is constant for each operation. Once the approximate filter life for your application is determined we recommend that a regular filter change schedule be set up before the filter out switches activate.*

Every Month:

1. Complete the two-week list.
2. Inspect the exhaust fan belt for correct tension and wear. All belts usually require adjustment at this time. Failure to tighten may result in the belt falling off and no airflow.
3. Inspect the bag filters (2nd stage filtration). Replace if necessary. The life of the bag filter depends on the type of cooking equipment and exhaust hood system. For heavy cooking applications the bag filters may require replacement every month.
4. **(Odor Spray Option)** Inspect the odor spray bottle. Refill if necessary. *At startup the odor spray is adjusted to the desired level. The amount of odor spray used varies with this initial setting. It is important to inspect the level in the bottle every two weeks until the normal rate of use is determined.*

Every Three Months:

1. Complete the two-week and monthly checklist.
2. Inspect the exhaust fan belt for correct tension and wear. Adjust if necessary.
3. Inspect the box filters (3rd stage filtration). Replace if necessary. Once again the life of the box filter depends on the type of cooking equipment and exhaust hood system. The box filter may provide one year of service on most applications with high efficiency water wash ventilators.
4. Inspect all electrical connections. Tighten if necessary.
5. Test the filter-removed circuit. Open the prefilter access door while the KES unit is in operation. The unit should shut down and indicate a filter-removed condition.

Every Six Months

1. Complete the two-week, monthly and three month check list.
2. Open the fan wheel access door or hatch on the KES fan section. Inspect the fan wheel for grease build up. Clean as required.
3. Inspect the exhaust inlet fire damper and fusible link. Replace link annually.
4. Check the motor and fan bearings for noise or overheating.
5. **(Odor Pellet Option)** Inspect the condition of odor media.

6. The odor media pellets can be checked for remaining life by sending a sample to an accredited test laboratory. Most major filter suppliers have access to such service. Replace media if required. To replace the media remove the cells from the KES unit. Open the side panel on each odor cell and pour out the used media. Refill the cells with new media. Shake cells while filling to allow pellets to settle evenly in the cell. **Note:** Do not allow odor media to come in contact with water, as this will immediately render the pellets useless.

Fan Bearings

1. STY and FYC bearings are factory pre-lubricated lifetime sealed and require no further lubrication.
2. SY and FY bearings are pre-lubricated and equipped with pressure grease fittings for re-greasing.
3. Under normal service conditions grease after six months of operation.

Motor Bearings:

1. All motors leave the factory with bearings custom greased for many years of service under most conditions.
2. Re-greasing of motors depends on the application and is best left to trained service technicians.
3. Periodically check if motor is running hotter than normal.

Centrifugal Exhaust Fan:

1. Make sure the wheel rotates freely before startup.
2. Inspect and clean the wheel periodically.
3. If dirt is allowed to build up the wheel could become out of balance and cause premature bearing wear.
4. A noisy fan is a typical sign of a fan out of balance.

V-Belt Drives:

1. ALWAYS KEEP SPARE SET OF BELTS. Periodically check the belt tension and adjust if necessary.
2. Some slack should be left in the belt, typically 1/4" per foot of belt from the fan to the motor sheave.
3. Always replace the complete set of belts to ensure even tension and wear. When replacing belts loosen the motor mounts.
4. Do not force belts over sheaves.

RECOMMENDATION

TO ENSURE TROUBLE FREE OPERATION FOR YOUR KITCHEN EXHAUST SYSTEM A PROPER PREVENTATIVE MAINTENANCE PROGRAM IS NECESSARY. SPRING AIR RECOMMENDS THAT A YEARLY SERVICE CONTRACT BE SET UP WITH A REPUTABLE SERVICE ORGANIZATION. THIS WILL REDUCE UNEXPECTED DOWN TIME TO A MINIMUM.

KES ENVIRO START-UP REPORT

Job Name		Date	
Location		File No.	
KES No.		Motor HP	
S/N		Voltage	

Item	Description	Y / N
1	Check all electrical connections. Tighten as necessary	
2	(RPD10 panels only) Check for power to the RPD10 panel on terminals 1 & 4	
2a	Check all remote wiring to ensure it has been connected	
3	(RPW10 panels only) Check wiring to terminals 1, 3 & 4 from water wash panel to RPW10 remote	
4	LV10 J-Box wiring to terminal 1, 4 & 5 from RPD10- or RPW10 remote	
5	LV10 J-Box wiring to terminal 4 & 5 to exhaust fan motor starter	
6	LV10 J-Box wiring to odor spray 4 & 17 (Optional for odor spray units)	
7	Power wiring to disconnect switch	

Check if all filters are in the unit

Type of Filter	Size	Qty
8	Prefilter	12" x 24" x 2"
9	Prefilter	24" x 24" x 2"
10	Bag Filter	12" x 24" x 22"
11	Bag Filter	24" x 24" x 22"
12	Box Filter	12" x 24" x 12"
13	Box Filter	24" x 24" x 12"

Item	Description	Y / N
14	Check of the inlet exhaust ductwork to the KES unit from the kitchen exhaust hood is all welded NFPA-96	
15	Check if clearance to top, sides, and ends of KES filter box is available: 18" to combustible or 6" to non-combustibles	
16	Check power at disconnect switch	3/60/ V
17	Check fan rotation as follows: Turn on the main disconnect to the KESF fan motor starter Turn "FAN ON" switch in the wash panel or remote RPD10 panel to the ON position Turn on the Override switch in the RPD10 or RPW10 remote panel. The LOGO text message "Service Filters within 4 hours" will appear. Turn "FAN OFF" switch in the wash panel or remote RPD10 panel to the OFF position. Observe the fan rotation. Change one of L1, L2 or L3 if fan is rotating backwards	

Item	Description	Y / N
18	Turn "FAN ON" switch in the wash panel or remote RPD10 panel to the ON position	
19	Check the FLA	L1 L2 L3
20	Adjust the overload setting on motor starter to FLA rating of motor	

Safety Circuit Check

21	Turn "FAN OFF" switch in the wash panel or remote RPD10 panel to the OFF position	
22	Rotate the OVERRIDE switch on the RPD10 or RPW10 to the original position. The text message will disappear once the fan is turned back on.	
23	Remove the front covers from all the pressure switches on the KES-ISH filter box.	
24	Turn "FAN ON" switch in the wash panel or remote RPD10 panel to the ON position	

Switch P1

25	Jumper switch P1- terminals 1 & 12	
26	KES unit shuts off	Yes No
27	Prefilter clogged light on and LOGO text message "Change Prefilter"	Yes No
28	Reset unit at LV10 J-Box reset switch by turning on and off	

Switch P2

29	Jumper switch P2- terminals 1 & 13	
30	KES unit shuts off	Yes No
31	Bag clogged light on and LOGO text message "Change Bag filter"	Yes No
32	Reset unit at LV10 J-Box reset switch by turning on and off	

Switch P3

33	Jumper switch P3- terminals 1 & 14	
34	KES unit shuts off	Yes No
35	Box clogged light on and LOGO text message "Change Box Filter"	Yes No
36	Reset unit at LV10 J-Box reset switch by turning on and off	

KES ENVIRO STARTUP REPORT page 2

Switch P4

33	Jumper switch P4		
34	KES unit shuts off	Yes	No
35	Filter removed light on and LOGO text message "Filter Out or Low Exhaust"	Yes	No
36	Reset unit at LV10 J-Box reset switch by turning on and off		

Switch P5

33	Jumper switch P5		
34	KES unit shuts off	Yes	No
35	Filter removed light on and LOGO text message "Filter Out or Low Exhaust"	Yes	No
36	Reset unit at LV10 J-Box reset switch by turning on and off		

Filter Out Test #1

33	Replace pressure switch covers and turn of the unit and remove all the bag filters. Shut the access door and turn the unit on. Wait for 30 sec.		
34	KES unit shuts off	Yes	No
35	Filter removed light on and LOGO text message "Filter Out or Low Exhaust"	Yes	No
36	Reset unit at LV10 J-Box reset switch by turning on and off		

Filter Out Test #2

37	Replace pressure switch covers and turn of the unit and remove all the box filters. Shut the access door and turn the unit on. Wait for 30 sec.		
38	KES unit shuts off	Yes	No
39	Filter removed light on and LOGO text message "Filter Out or Low Exhaust"	Yes	No
40	Reset unit at LV10 J-Box reset switch by turning on and off If the unit does not shut off and the filter clogged light does not come on for this test the pressure switch setting must be adjusted. With the filters out rotate the pressure adjustment screw slowly clock wise until the unit shuts off.		

Fire Switch Test

41	Jumper terminals 1 & 16 in the LV10 J-Box.		
42	KES unit shuts off	Yes	No
43	Fire light on	Yes	No
44	Reset unit at LV10 J-Box reset switch by turning on and off		

Check override switch

45	Turn "FAN OFF" switch in the wash panel or remote RPD10 panel to the OFF position		
46	Jumper terminals 1 & 12		
47	Turn "FAN ON" switch in the wash panel or remote RPD10 panel to the ON position		
48	After 30 seconds the KES shuts off, the Prefilter Clogged light turns on and the LOGO text message "Prefilter Clogged" will appear.		
49	Rotate the OVERRIDE switch on the RPW10 or RPD10 remote panel to the ON position.		
50	KES unit turns on	Yes	No
51	Warning light turns on and the LOGO text message "Service Filters within 4 hours" will appear.	Yes	No
52	Turn "FAN OFF" switch in the wash panel or remote RPD10 panel to the OFF position		
53	Remove the jumper		
54	Turn "FAN ON" switch in the wash panel or remote RPD10 panel to the ON position		
55	Rotate the OVERRIDE switch on the RPW10 or RPD10 remote panel to the OFF position. The Warning light goes off and the LOGO text message disappears.		
56	Measure the exhaust air volume at each hood Use hood start up form for this		

Comments:

Service Technician: _____

Yes I have received a set of Spring Air Systems Inc. maintenance manuals.

Signature _____ Print Name _____

FILTER FREQUENCY CHART

Enter the date of each filter change				
Startup date				
Change No.	Prefilter	Bag Filter	Box Filter	Odor
1				
2				
3				
4				
5				
6				
7				
8				
9				
10				
11				
12				
13				
14				
15				
16				
17				
18				
19				
20				
21				
22				
23				
24				
25				
26				
27				
28				

Other Fine Products From

SPRING AIR SYSTEMS...

Water Wash Ventilators

- Hot Water Wash
- Cold Water Spray/Hot Water Wash
- Water Wash Control Panels

Dry Ventilators

REV-LOW Hood

Filter Hoods

Surface Fire Suppression

Commercial Kitchen Exhaust Fans

Kitchen Enviro Systems

- KES - 100% Exhaust

Commercial Kitchen Supply Units

Bio Spray Hoods

Compensating Hoods