



KES ENVIRO TOUCHSCREEN

Maintenance Manual

Spring Air Systems Inc., Oakville, Ontario
Phone (866) 875-4505, Fax (905) 338-0179, info@springairsystems.com www.springairsystems.com

June 2010

Introduction	2
The System Components	2
Filter Section	3
Filtration	3
Bag filters	3
Box Filters	3
Control Circuit	4
Fire Damper	5
High Limit	5
Optional Fire Suppression	5
Fan Section	6
MXFlow	7
Components	7
Variable Frequency Drives (VFD)	8
Operation	8
Optional Odour Module	9
Odor Pellets	9
Odor Spray	9
Touchscreen Operation	10
Logging into the Touchscreen	11
Dashboard Window	12
Power Window	13
Operation Status Window	14
What to do in the event of an alarm	14
Common alarms reported by touchscreen:	14
Primary Toolbox window	15
Viewing Filter Alarm Report	15
Changing Time to Dashboard	16
Setting the automatic Opening and Closing Times	16
Waterwash Setup	17
Odour Spray Setup	17
Adjusting the Odour Spray	18
Secondary Setup Window	19
Viewing Drive Parameters	19
Viewing VFD Frequency Settings	20
Kitchen Setup	21
Filter Annunciation	22
Filter Clogged Alarm	22
Filter Removed Alarm	23
Surface Fire Alarm	23
Setting Up a Filter Change Schedule	24
Where to Purchase Filters	25
Suggested Maintenance Schedule	26
APPENDIX	30
A. PXR3 Micro-controller: Factory setup	30
B. Sensor Fault Operation	31
C. Factory Drive Terminal Schematic	32
D. Logic Input Switch	33
E. Technical Specifications for Locating VFD	34
F. Hazardous Warning	35
G. Good Wiring Practice	36
H. Grounding	37
I. Manually Starting the Drive	38
J. Accessing the Drive Program Menu	39
K. Programming the Drive Parameters	40
L. Drive Factory Reset	48
M. Troubleshooting and Drive Fault Display	50
N. Touchscreen Factory Wiring	53
O. Odor Spray Compressor Maintenance	55
P. MSDS Sheet C-10	56
Q. MSDS Sheet Spring Fresh	58
R. Touchscreen Initial Set-up	60
S. Changing Exhaust Air Volume on Site	66
T. Field Connecting the KES-ISH Filter Box and KESF Fan Box	68
U. Hanging the KES-ISH Filter and KESF Filter Box	69
V. KES Unit Weight Chart (lbs)	70
W. Touchscreen Troubleshooting Sheet	71

INTRODUCTION

Thank you for purchasing a Spring Air Systems commercial kitchen ventilation product. Please read the complete “KES Enviro with Touchscreen Operation and Maintenance Manual” prior to installation, commissioning or operating a KES unit.

The SPRING AIR SYSTEMS INC. Kitchen Enviro System (KES), Exhaust Cleaning Assembly for Kitchen Exhaust Duct, “Enviro Unit” is ULC and UL listed for use in a commercial kitchen exhaust system. KES units are available in sizes ranging from 1,000 CFM to 40,000 CFM for indoor or outdoor applications.

The primary function of a KES Enviro unit is to filter the grease, lint and dust particles and remove the odor from the exhaust air.

The Underwriters’ Laboratories of Canada Limited (ULC) listing allows the use of non-NFPA-96 exhaust ductwork after the exhaust air is discharged from the KES unit. In other words the discharge ductwork can be treated similar to standard HVAC ducting. Also after the kitchen exhaust air has been treated with the KES unit the exhaust can be discharged outdoors at low levels.

The ULC Online “YXLTC.Guide: Info for Ventilating Equipment for Restaurant Cooking Appliances” states: This category covers filter units, cleaning and recycling assemblies, exhaust hoods, grease ducts, grease duct insulation, power ventilators and other apparatus intended for installation as parts of ventilating and exhaust systems serving restaurant-type cooking appliances and in accordance with ANSI/NFPA 96, “Standard for Ventilation Control and Fire Protection of Commercial Cooking Operations.” Where there are differences between the particular requirements contained in ANSI/NFPA 96 and the ULC Standard indicated in the individual product categories, the requirements of the ULC Standard shall govern unless explicitly stated otherwise by the Authority Having Jurisdiction.

The Underwriters Laboratories Inc. (UL) listing allows the kitchen exhaust air to be discharge to atmosphere at low levels.

Prior to any installation the installer must seek approval from the authorities having jurisdiction.

THE SYSTEM COMPONENTS

The grease-laden air rises from the cooking equipment into a UL or ULC exhaust hood. The exhaust hood removes some of the airborne grease particulate. Typically most micron and all submicron particles escape into the exhaust ductwork. The exhaust ducting is connected from the hood to the inlet of the KES Enviro unit. This exhaust ductwork must be supplied and installed in accordance with the NFPA-96 code.

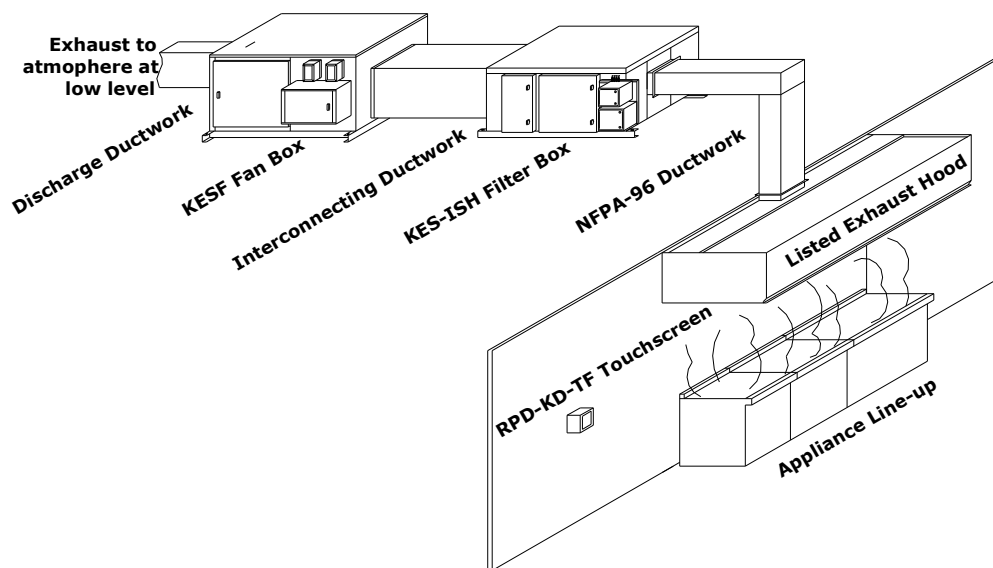

Typical KES System Schematic

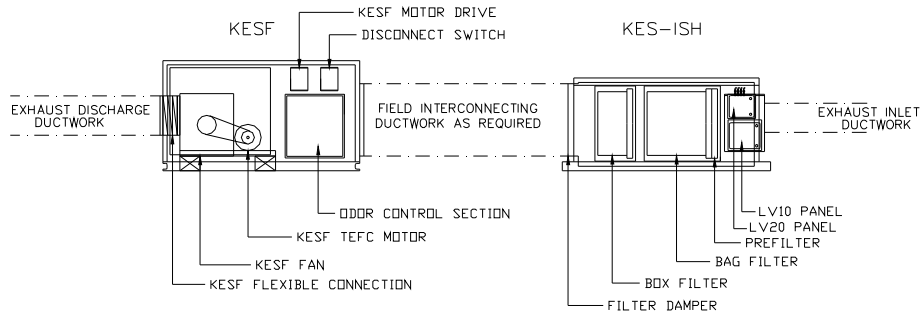

KES-ISH and KESF Enviro components

KES ENVIRO FILTER UNIT (KES-ISH)

The unit is constructed of 16 gauge steel inner shell, continuously welded and liquid tight in accordance with the NFPA-96. The outside of the unit is wrapped in 1.5" insulation and 18 gauge steel protective covering primed and painted. Channels running along the length of each side support the unit. Lifting and support points are at the four corners of the KES-ISH unit at the ends of these channels. No external isolation of the unit is required. The two access doors are double wall construction with 1.5" insulation and cam lock door fasteners per the UL/ULC fire rated listing.

The KES filter section contains the three-stage filtration to remove grease, dust, and lint particulate from the air captured at the exhaust hood. The quantity and size of the filters is determined on the size of the KES unit.

PRE FILTERS – first stage

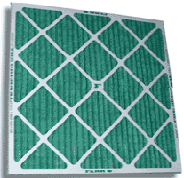

Rated at **MERV7 (30% ASHRAE 52-76) ULC/UL Class II.**

BAG FILTERS – second stage



Rated at **MERV13 (90-95% ASHRAE 52-76) ULC/UL Class II**

BOX FILTERS – final stage



Rated at **MERV16 (95% DOP / 99% ASHRAE 52-76), ULC/UL Class II**

CONTROL CIRCUIT

During normal operation of the KES unit three-filter stages collect grease, dust, and lint particulate. The type of cooking equipment and product cooked as well as the hours of operation determines the useful life of the individual filters.

Pressure transducers determine when the filters are totally used and must be replaced. The static pressure across each filter increases as the filter reaches the grease/dust loading capacity. When the maximum static pressure is reached the transducer activates a PLC output. The exhaust fan shuts off and the Touchscreen panel annunciates a filter-clogged condition. In addition the screen of the PLC in the RPD-KD or RPD-KW has a text message also indicating which filter is clogged.



Copper pressure tubing from the pressure transducers is run inside along the top of the unit to pressure probes located in front and behind each filter section.

Box Filter probes as viewed from discharge

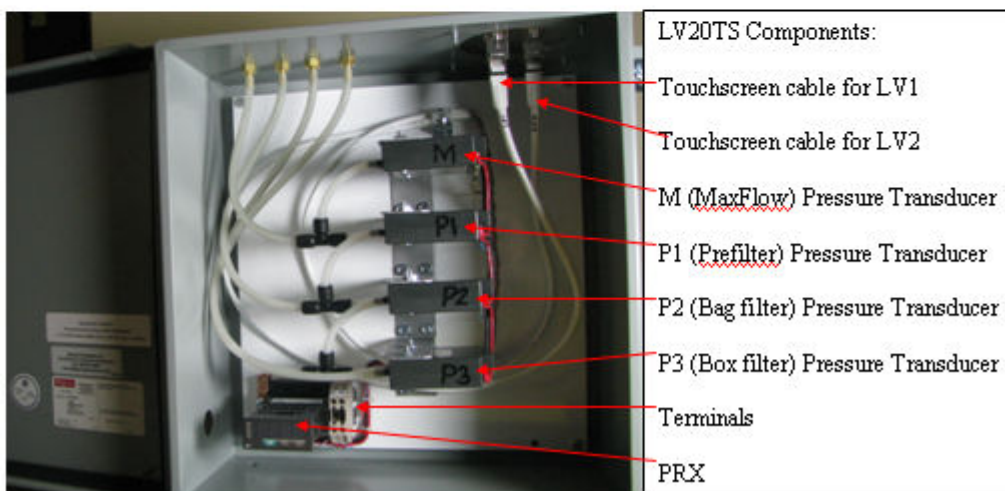
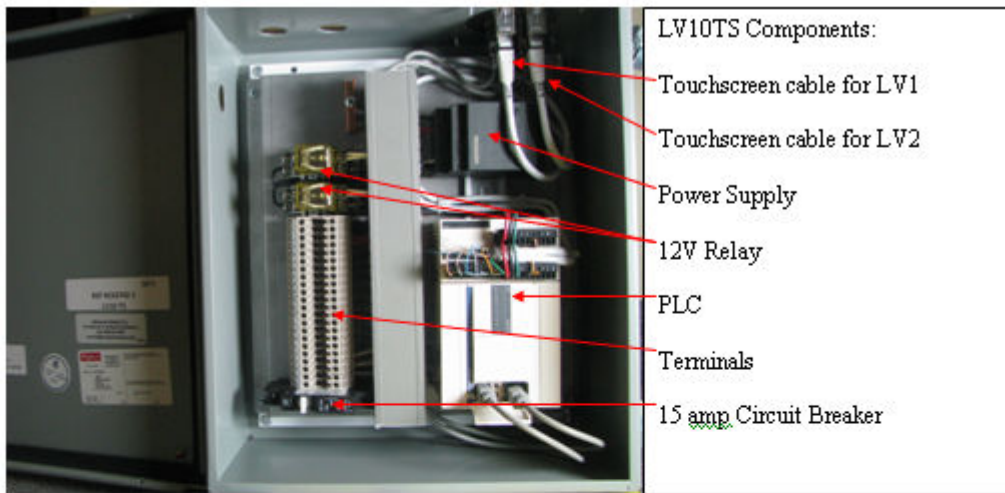

Fire Damper



The fire damper (shown here in a KES still under construction) is located between the fan and filter sections and is accessible through the Prefilter/Bag filter access door.

It is held open by a fusible link that will melt once a rated (165° F) temperature is reached inside the KES unit.

High Limit



The high limit is located at the exhaust inlet end and mounted on the same side as the LV10 panel.

Optional Fire Suppression



All KES units come factory pre-piped for fire suppression. The pre-piping includes the hole and seal through which fire suppression discharge pipe and detection lines are run.

Units that are specified with full fire suppression will also include all necessary components for a fully operational fire suppression system.

KESF ENVIRO FAN UNIT

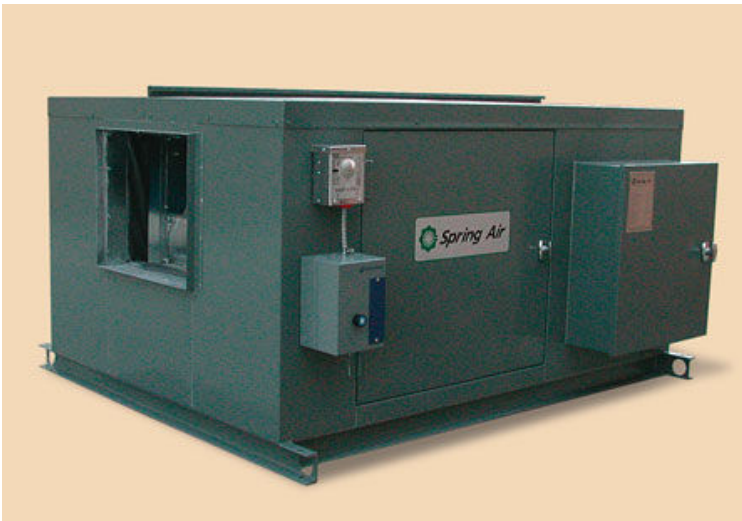

The *KESF Enviro Fan* unit contains the exhaust fan, exhaust fan motor, drives, and belts, disconnect, variable speed drive for MxFlow operation, isolators and optional odor reduction section spray or pellets.

The unit casing is 16-gauge steel, primed and painted, suitably reinforced to ensure rigidity. An optional sound attenuation package is available for the interior of the fan unit. This package is highly recommended on all indoor units. Channels running along the length of each side support the KESF unit. Lifting and support points are at the four corners of the KESF unit at the ends of these channels. An access door is provided for the exhaust fan/ motor and drive section.

Every KESF unit is equipped with a backward-inclined; AMCA rated, Class II, exhaust fan with heavy-duty bearings, and two groove sheaves. The Class of the fan is dependent on the total static pressure and CFM of the system. The Class II blower will handle up to 7.5" W.C. total static pressure. The following options are also available:



Single Width, Single Inlet (SWSI) or Double Width, Double Inlet (DWDI): The standard unit comes with a DWDI fan package. The DWDI is preferred when the exhaust discharge is straight through the KESF Fan unit. The DWDI can also discharge up or down from the KESF fan unit but not out the sides. DWDI exhaust fans up to 8,000 CFM are stocked at the Spring Air factory.

The SWSI fan is preferred if the exhaust discharge from the KESF Enviro fan unit is required to be at right angles (Out the Side) to the exhaust discharge.

The KESF fan unit is always **internally** isolated. The KESF fan unit has spring mounted isolators inside the KESF fan unit and does not require any external flexible connection outside the unit.

MXFLOW

MXFlow is designed to increase filter life while maintaining maximum exhaust volume during the commercial kitchen cooking operation. Immediately after commissioning the KES unit the exhaust air volume is at the highest level. As each of the three filter sections captures grease particulate of micron and submicron size they begin to fill and the air resistance through each filter increases. Even though the KESF unit has a heavy duty, Class II, backward-inclined fan the increase in combined resistance (static pressure “W.C.”) through each filter will gradually reduce the exhaust volume. In cases where there is very heavy cooking with large quantities of micron and submicron grease particulate the reduced exhaust volume is most noticeable. In some cases the filters may have to be changed not because the filter is clogged but because the combined static pressure resistance through all the filters has reduced the exhaust volume enough to affect smoke capture. This is less of a problem with lighter cooking operations.

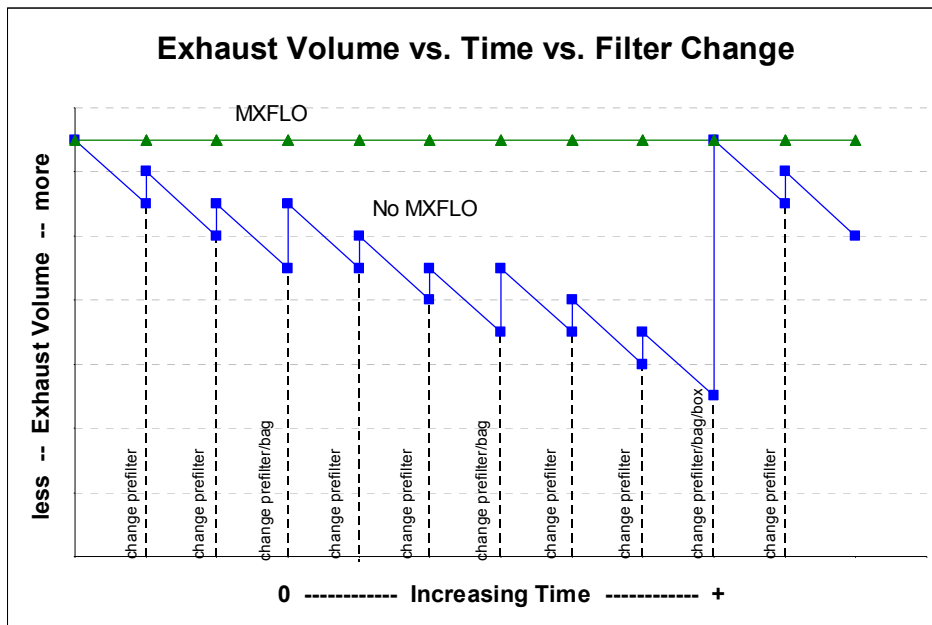

In the example above the “No MXFlow” KES unit exhaust volume (shown in BLUE) gradually drops as the filters become increasingly clogged. Even when the prefilters and bag filters are replaced the exhaust volume does not return to maximum because the box filter continues to clog. This drop in exhaust volume generally only represents about 10% of the total exhaust volume. But in some cases this can be enough to affect the hoods ability to capture smoke adequately.

The “MXFlow” KES unit incorporates a combination pressure transducer/microprocessor and variable speed drive to maintain constant exhaust volume regardless of the increased static pressure through any of the particulate filters. As the pressure across any filter increases and the exhaust volume decreases the pressure transducer/microprocessor senses this change and automatically increases the exhaust fan speed to compensate for the increased static pressure to maintain a constant exhaust volume.

MXFlow also allows for one touch exhaust volume adjustment when commissioning the unit; thereby making commissioning a more straightforward process. Additionally MXFlow eliminates the need to change sheaves. If the exhaust volume needs to be field adjusted because of an appliance change or ductwork change the MXFlow provides exhaust volume adjustment, up or down, with the touch of a single button.

MXFlow Components

The MXFlow is factory installed and tested prior to shipment. The components consist of the MXFlow control panel model LV20 in conjunction with an exhaust fan motor variable speed controller.

The MXFlow components are located in the LV20 panel. The MXFlow components include the pressure transducer (PT), and micro-processor (DMP). When the operator turns on the KESF exhaust fan the motor starts. In addition a 24V power supply activates both the digital readout on the micro-processor and the PT. The (+ve) pressure port on the PT is vented to atmosphere and the (-ve) pressure port is piped into the inlet of the KES-ISH filter box. The probes measure the external static pressure on the inlet of the KES-ISH filter box. The DMP is factory set to the filter box inlet static pressure

as indicated on the KES LV10 drawing. The PT is located in the LV20 panel with the pressure probes existing from the top. One probe enters the unit casing and the other is vented to atmosphere.

Variable Frequency Drives (VFD)

The variable frequency drive is mounted on the KES fan section next to, or below, the disconnect switch. The VFD is connected to the LV20 panel by a shielded CAT5 cable. This cable is factory supplied. The drive changes the AC frequency to the exhaust motor between 18Hz and 70Hz.



VSD front

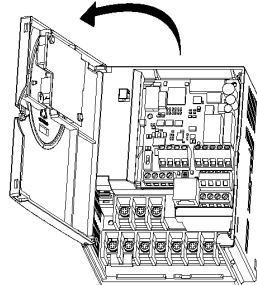

VSD open front

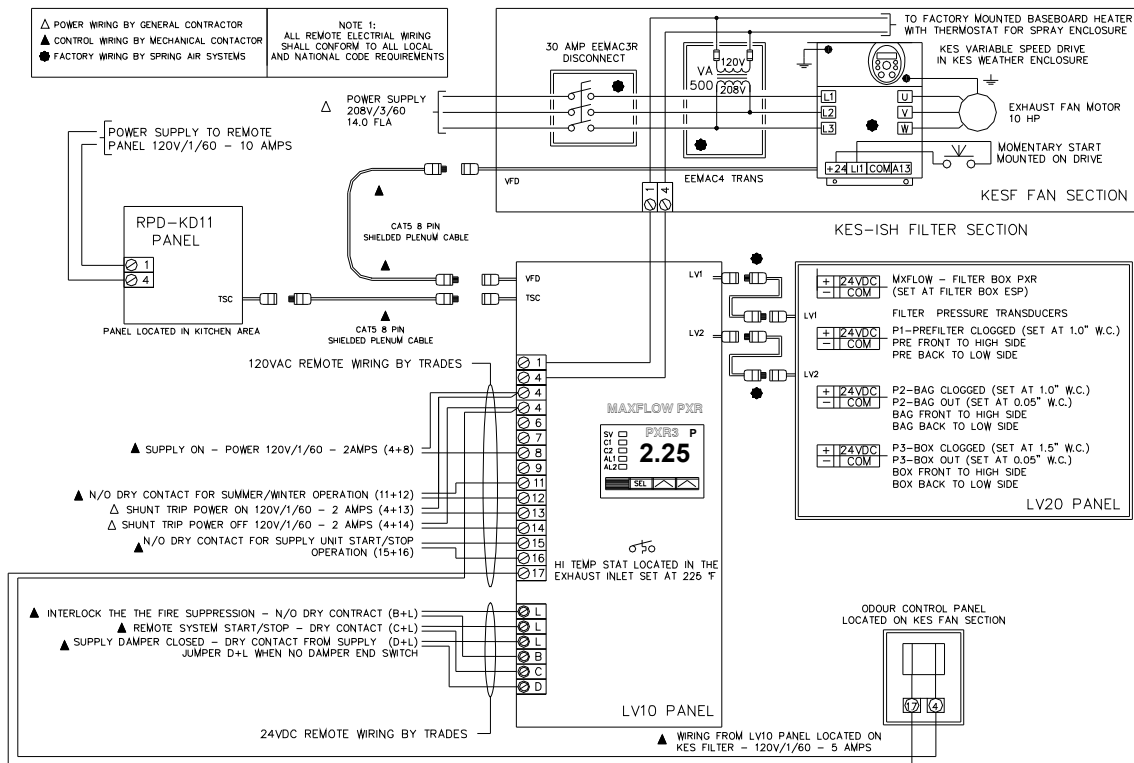

Typical indoor KES, motor starter, LV10 wiring schematic with optional odour spray

MXFlow Operation

As a filter clogs, the pressure drop through the filter increases, decreasing the exhaust air volume, and decreasing the static pressure measured at the PT. The PT sends a signal to the DMP to increase the static pressure back to the set point by increasing fan speed. The result is a constant exhaust volume until the filters are full and must be replaced.

Optional Odour Module

Once through the particulate filter sections the exhaust air enters the optional odor removal section. The odor section is only required when discharging cooking smells may be offensive. This section consists of two optional odor removal systems.

1. Odor Cells filled with activated alumina impregnated with potassium permanganate. The odor is controlled through a combination of sorption and the chemical modification of the gaseous contaminants. The odor media is non-toxic (disposal non-hazmat) and non-flammable.

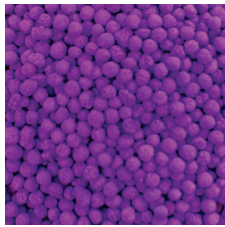

New odour pellets

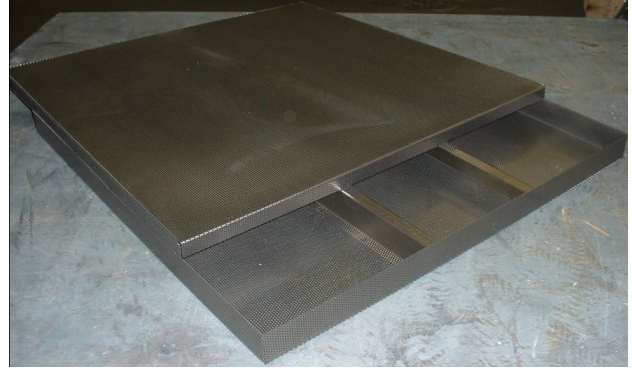

Unfilled odor tray

2. Odor Spray solution. The odor is control by spraying an odor reducer into the exhaust air stream intermittently during the operation of the cooking systems. The odor spray unit is normally located mounted on the KESF fan section. The cabinet includes an air compressor, atomizing air nozzle and piping and odor spray container.

The duration and length of the spray can be adjusted by using the Touchscreen.



Odor Spray components

Touchscreen Operation



The exhaust system is operated through a Touchscreen control panel. The Touchscreen allows users to turn the system on, off, set up an automatic start/stop schedule, and monitor the status of the KES filters all through the Touchscreen. The Touchscreen also keeps a record of system messages that are useful for service technicians to diagnose and correct problems.

The date, time, kitchen name, and automatic schedule times can be changed on the Touchscreen by logging in.

There are four main windows on the Touchscreen:

1. Dashboard

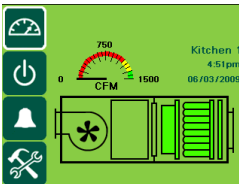

The **Dashboard** is the heart of the KES system. It displays the current system status.

2. Power



The **Power** window provides access to the exhaust components controlled by the Touchscreen panel. Users can turn the system on, or off, change the makeup air between summer and winter mode, and access the filter use graph.

3. Operation Status

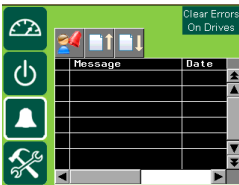

The **Operation Status** window provides a list of current and previous messages that have been recorded by the Touchscreen. A few of the recorded messages are filters requiring changing, power outages, and high temperature. Users will need to go to this screen to clear a message. The red message indicates an active message, a green message indicates a cleared message, and a yellow message indicates the message is still active, but has been acknowledged.

4. Primary Toolbox

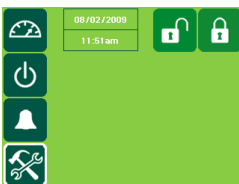

The **Primary Toolbox** window allows users to make changes to the date, time, automatic opening and closing times, along with the time to dashboard, odour spray timer and waterwash timer.

The window shown left is the Primary Toolbox before logging in. The screen shown right will be available once a user is logged in.

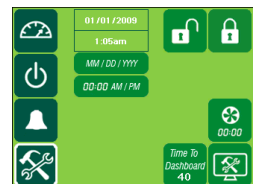

Logging in and out of the Touchscreen

In order to make any changes to the system setup, a user must log in. Management and Administrative log in have different levels of setup access.



Touch the **Primary Toolbox** icon.

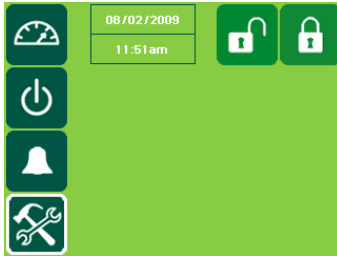

Touch the **Login** icon.

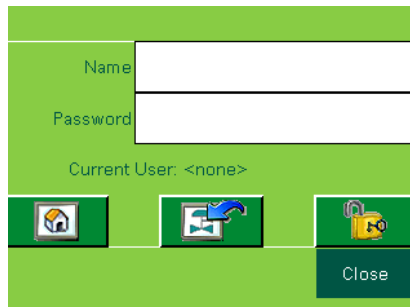

Touch the white field beside **Name**.

Type your username in the pop-up keyboard.
Touch **Enter** key.
Window returns to the Login window.



The login name is case sensitive. The CAPS key is on automatically.

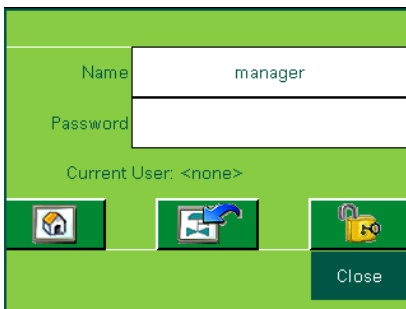

Touch the white field beside **Password**



Type your password in the pop-up keyboard.
Touch **Enter** key.
Window returns to Login window

The password is also case sensitive.



Touch the **UNLOCK** icon.
Touch the word **Close** to close the login box.

You have completed the login.

Logout

The Touchscreen will automatically log out users after a pre-set length of time (Time to Dashboard).



Touch the **Primary Toolbox** window button.



Touch the lock.

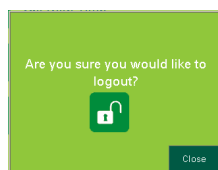

Touch the lock again.

You are now logged out.

The **Dashboard** is the heart of the KES system. It displays the current system operating status.

Example dashboards:

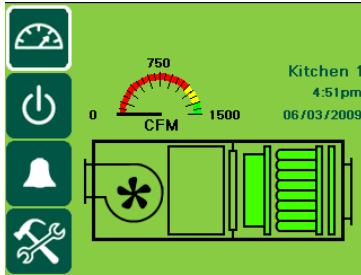

Normal Operation

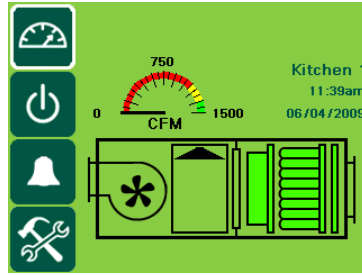

Normal Operation with odour spray

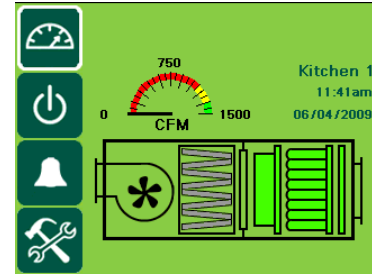

Normal Operation with odour pellets



Operating CFM Dial indicates the current operating CFM. When the filters become so clogged that the motor can no longer compensate, this dial will drop down into the red section. Be sure to change filters *before* the system shuts down.



Kitchen Name, Time and Date. These can all be changed through the **Primary Toolbox**.



Fan Status will indicate if the KES is turned on or off. When the KES is on, this icon will rotate.



Odour Spray. If the KES is equipped with odor spray, this icon will be shown spraying when the spray is discharging.



Odour Pellets. If the KES is equipped with odor pellets, this icon will be visible.

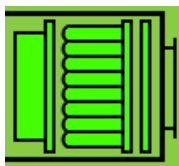

Filter Status. This area indicates the filter status (from right to left) for the pre filters, bag filters and box filters.

The filter icon will change color first to yellow, and then to red, as it become clogged with grease and particulate. Touching this area will open the Filter Status Window.

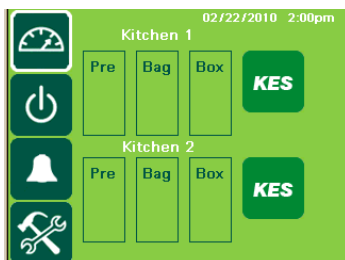

Multiple KES display.

Touch the KES icon beside either kitchen to access the KES unit's individual **Dashboard** window.

The **Power** window provides access to the exhaust components controlled by the Touchscreen panel. Users can turn on or off the KES, change the makeup air between summer and winter mode, and access the filter use graph.



Single KES Display



Multiple KES Display



Fan Status icon. *Touch* this icon to turn the system on and off. When system is on, the icon has a white border and the fan rotates.



Return to Dashboard. Touching this icon will return the Touchscreen view to the **Dashboard** window.



Manual System Operation.
Touch icon to operate exhaust system manually.

When manual operation is engaged, icon has white border and exhaust system will need to be turned on and off manually every day from the **Power** window.

Scheduled start/stop times for an automatic schedule can be set in the **Primary Toolbox**.



Filter Use Graph will plot the average static pressure reading for the filters at the end of each day. This information is used in determining a filter replacement maintenance plan.



Summer/Winter icon.
Touch icon to switch between summer and winter mode.
When in winter mode, makeup air burner will activate as required to maintain makeup air temperature.

The **Operation Status** window provides a list of current and previous operation messages that have been recorded by the Touchscreen. A few of the recorded messages include filters requiring changing, power outages, and high temperature. Users will need to go to this screen to clear a message.

Accessing the Operation Status Window:

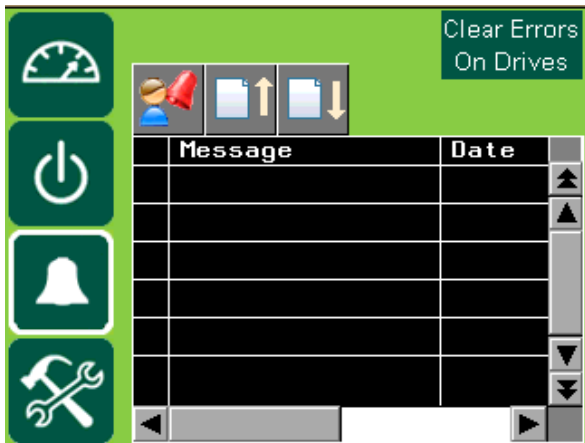

Touch the **Operation Status** icon.



Acknowledge Message icon. Messages must be acknowledged before they can be cleared. Unacknowledged messages will show in red on the list; acknowledged messages will be yellow or green.



Move Up one page.



Move Down one page.

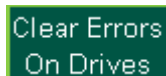

Clear Com or Comport error. This icon must be pressed whenever there is a COMM PORT or COMM error after the fault has been acknowledged and corrected to resume normal operation.

What to do in the event of a message:



Messages will change the screen to red with a yellow exclamation mark.

Touch the screen anywhere to go to the **Operation Status** window.



Touch the **Acknowledge Message** icon. This will turn all current messages yellow.

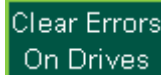

Touch the **Clear Errors on Drives** icon. This will turn the current messages that can be cleared locally green.

If there are any messages remaining yellow, these must be cleared by resetting the variable speed drive. To reset the variable speed drive, follow these steps:

1. Turn off the disconnect on the KES unit.
2. Leave the disconnect off until all lights and the display on the VFD turn off.
3. Turn the disconnect back on.
4. Turn the KES unit back on using the Touchscreen.

If the alarm returns, refer to the Troubleshooting Sheet, or contact Spring Air for assistance.

Common messages reported by Touchscreen:

Message on screen:	Cause:	What to do:
Pre/Bag/Box filter clogged	The pre, bag, or box filter has been totally used. The filter status bar will show red.	The KES will shut down and can only be operated in Override. Replace clogged filter and reset system.
Bag/Box filter Out	The bag or box filter has been removed or the filter door is open.	Check if the filters are removed or the KES filter door is open.
High Temperature	The temperature inside the KES has reached a high limit.	Check filter statuses, make sure fire damper is open, check belts.

The **Primary Toolbox** window allows users to make changes to the date, time, automatic opening and closing times, along with the time to dashboard, odour spray timer and waterwash timer. This window will not be available until a user logs in. Not all settings will be accessible or changeable by Management users.

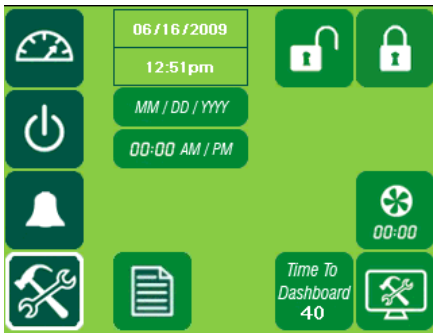

Example Primary Toolbox window

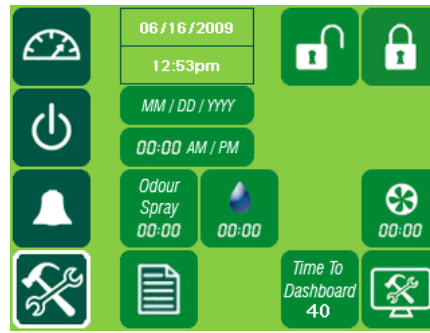

Example Primary Toolbox with Waterwash and Odour Spray

Viewing Filter Message Report

The Filter Message Report provides a list of dates, times and stage of filter alarms. It includes both filter clogged and filter out messages.



Press the Filter Message Report icon.

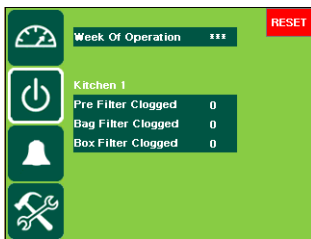

The Filter Message Report window lists the number of times each stage of filter has been changed.

This report can be reset by touching the red **reset** icon on the top right-hand corner of the window.

Changing Date and Time

The Touchscreen will update itself for Leap Years; however a user will need to adjust the time for daylight savings.

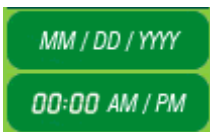

Touch the green field with the date or time.

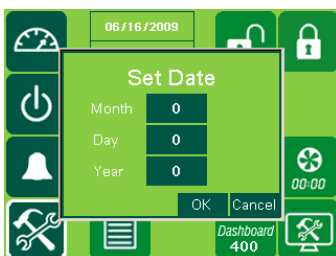

Touch the Month, Day or Year field.

Type the new setting using the pop-up keyboard. Touch **enter** to return to the Set Date window. Touch **OK** to return to the

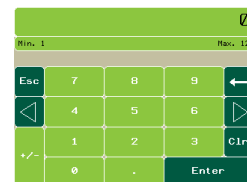

Changing Time to Dashboard



Touch the Time to Dashboard icon adjust the number of seconds before the Touchscreen returns to the **Dashboard** window.

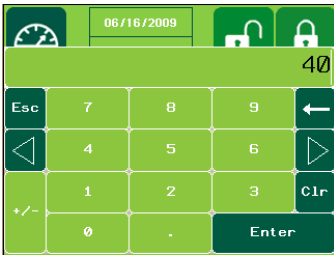

Type new setting (in seconds) using the pop-up keyboard.
Touch **enter** to return to **Primary Toolbox** window.

Setting the automatic Opening and Closing Times

An automatic time for the KES system to turn on and off can be set up for each day of the week. The system will need to be turned to Automatic via the **Power** window for the schedule to run.



Touch **Automatic Schedule** icon to set automatic opening and closing times.

The Automatic Schedule window will become available.

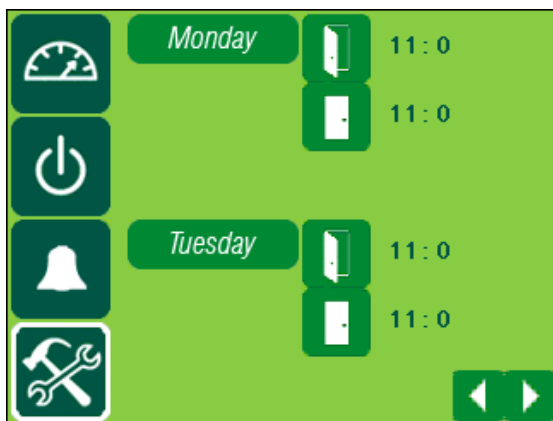

Touch the **open door** icon to change the time for the kitchen exhaust system to turn on.

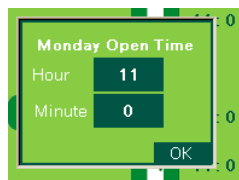

Touch the dark green field to open the pop-up keyboard and adjust the hour and minute for the kitchen exhaust system to turn on. Hour setting is based on 24-hour. Press **enter** to save.

Touch **OK** to return to the **Automatic Schedule** window.



Touch the **closed door** icon to change the time for the kitchen exhaust system to turn off. Follow the same steps as for the Opening Time to adjust the hour and minute for each day.



Touch the **next page** (the arrow facing right) icon for to set times for the remaining days of the week.

Touch the **previous page** (the arrow facing left) icon to return to the **Primary Toolbox** window.

An on/off time will need to be set for each day **Manual System Operation** will *not* be selected on the **Power** window. If the Kitchen does not operate on a given day, make the start and stop time the same and the kitchen exhaust system will not operate that day.

Optional Equipment Setup

Waterwash System

If the hoods connected to the KES unit are equipped with a water wash system, this system can be controlled by the KES Touchscreen.



Touch the **Water Wash** icon to open the **Set Water Wash Timers** window.

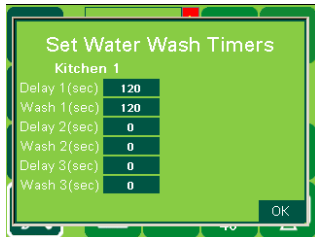

Touch the dark green field next to **Delay 1**.

Type the new length of time (in seconds) the exhaust system will be off before the first wash system's cycle begins. Touch **enter**.



Touch the dark green field next to **Wash 1**.

Type the new length of time (in seconds) the first wash system's cycle will run.

Repeat these steps for each wash cycle (if there is more than one).

Odour Spray System

How does it Work?

The odor spray setting is a qualitative measurement. The spray timers are field set to provide adequate odor reduction for the installation. This is completely subject to what a particular person feels is an acceptable discharge odor.

During the spray timer activation the combination air compressor and air-atomizing nozzle injects a volume of odor solution into the exhaust discharge. This solution is carried along the discharge duct and vented to atmosphere. The spray solution chemically activates with the kitchen exhaust air to reduce the kitchen exhaust odors. As the solution is carried down the duct some adheres to the duct walls. We will call this the spray residue. During the cycle time when the spray is not activated this spray residue continues the odor reducing process as the exhaust air passes. Therefore installation with longer discharge ducts can normally use a longer cycle time because there will be more spray residue. A shorter run of discharge duct usually results in shorter cycle time.

A. When adjusting the timers the object is to use as little spray solution as possible to provide adequate odor reduction:

1. First adjust the spray cycle timer.
2. Reduce this setting by $\frac{1}{2}$ of the original cycle setting and check the operation. If $\frac{1}{2}$ proves adequate, increase the cycle back to $\frac{3}{4}$ of the original cycle setting. If this is adequate increase to $\frac{7}{8}$ of the original setting and so forth.
3. If reducing the setting by $\frac{1}{2}$ is not adequate decrease the cycle to $\frac{1}{4}$ of the original setting. If this is not adequate adjust the spray timer.
 - a. Increase the spray time in increments of 5 seconds. After each 5 second increase evaluate the quality of the exhaust discharge air to determine if it is acceptable to the user.
 - b. When the spray timer setting equals the cycle timer settings the spray will be continuous. The maximum setting of B02 should not exceed the cycle timer.

The odor spray bottle must be changed regularly depending on the length of time set on the timers. The odor spray line from the spray bottle to the spray nozzle must be cleaned every 6 months in a water and detergent mixture. The compressor air gauge should read between 10 and 15 psi. When the air gauge is reading below 10 psi clean out the compressor air line. If the pressure is still low proceed to the next step compressor maintenance.

When there is odor in adjoining floors or office spaces

A kitchen located in the interior of an office building must be very negative to keep the kitchen odor within the kitchen. We recommend the kitchen be a minimum 20% negative. The fresh air supply is 80% of the total exhaust air from the kitchen space. When there is odor in adjoining spaces check the following.

1. The kitchen is not negative enough to keep the smell of the kitchen in the kitchen. If this is the case the odor is usually present all the time, even when there is no cooking. Reduce the amount of fresh air to the kitchen by adjusting the supply fan volume.
2. The kitchen may be connected to the same building A/C unit as the rest of the floor. If this is the case the return air grilles in the kitchen draws the kitchen odor to the main A/C unit and disperses the odor throughout the floor. The main A/C return must be blocked from the kitchen and put on a separate A/C unit.
3. The floor above the kitchen have odor. There are three possibilities.
 - a. The exhaust shaft is not sealed and the kitchen exhaust is leaking out onto the floors above the kitchen. Either adjust the amount of odor spray per section "A" above or install an exhaust fan on the roof to draw the kitchen exhaust to the roof and maintain a negative pressure in the discharge duct.
 - b. The odor may escape when the kitchen is not operating during the night. After the kitchen is shut off kitchen odor may migrate up the exhaust duct and leak out into the adjoining floors. This can be solved by operating the kitchen exhaust for several hours after the cooking has stopped for the day and starting the kitchen exhaust fan an hour before cooking starts in the morning.

Adjusting the Odour Spray



Touch the **Odour Spray** icon in the **Primary Toolbox** to open the **Set Odour Spray** window.



Touch the dark green field next to **Cycle**.

Type the new length of time (in seconds) between sprays using the



pop-up

Touch the dark green field next to **Duration**.

Type the new length of time (in seconds) the spray discharges. The higher this number, the longer the spray.

Secondary Setup Window

The Secondary Toolbox provides access to KES Touchscreen system setup features and variable speed drive information.

The Managers login will only have access to view this information. The Administrative login has access to change some setup and drive settings.



Touch the Secondary Setup icon on the Primary Toolbox window.



Viewing Drive Parameters



Touch the Kitchen 1 bar to view all fan drives connected to the Kitchen 1.

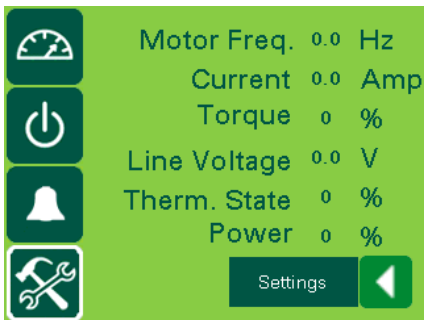

After touching the *Kitchen 1* bar the drive parameters can be viewed for that specific kitchen.

The user can not change any parameters. The user can view Motor Frequency, Current, Motor Torque, Line Voltage, Thermal State, and Motor Power.



Touch the Left Arrow key once to return to the Secondary Setup Screen.

Viewing VFD Frequency Settings

 Settings

Touch the **Settings** icon to view the VFD Frequency Settings.

Access to the VFD Frequency Settings will only be available when logged in with administrative permissions and the fans are turned off.



Touch **read speed** for Min freq. The field will turn pink for several seconds, then display the current minimum operating frequency on the drive.

Touch **read speed** for Max freq. The field will turn pink for several seconds, then display the maximum frequency on the drive.



If it is necessary to change the minimum or maximum frequency of the VFD, Touch the field to the left of Write Speed under Min. freq.



Using the pop-up keyboard, type in the new minimum frequency. Touch **enter** to return to the VFD Frequency Settings window.

Touch **write speed** for Min. Frequency. The new setting is now saved (written) to the drive.

Repeat these steps for Max. Frequency.

Kitchen Setup

Only users with administrative settings will have access to these windows. These items will all be pre-set in the factory; however they can be changed at anytime in the field.



Touch the **Kitchen Setup** icon.



Single Unit Window



Multiple Unit Window



Up to two KES units can be controlled from a single Touchscreen panel. To adjust the number of KES units, touch the up or down arrows.



Touch the dark green field under **Kitchen Name** to change the name displayed.

Use the pop-up keyboard to type in the new name.



If the hoods connected to the KES unit are equipped with a water wash system, *touch* the checkbox beside **Water Wash** to include it in setup options.



If the KES unit is equipped with an odour spray module, *touch* the checkbox beside **Odour Spray** icon to include it in setup option.



If the KES unit is equipped with odour pellets, *touch* the checkbox beside **Pellets** to include.

Filter Annunciation

This section will discuss how to check the status of the filters in the KES unit.

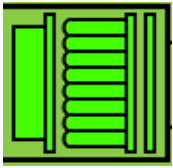

From the **Dashboard**, *Touch* the **filter status** area. The **Filter Status** window will open.



The first bar indicates the amount that the Pre Filter that has been used. The bright green area is the used portion of the Pre Filter and the green area above the bright green area is the portion left. The 0.55 value is the pressure drop in inches W.C. across the filter.



The second bar indicates the amount of the Bag Filter that has been used. The yellow area is the used portion of the Bag Filter. The yellow color indicates that the filter is about to run out of life and needs to be replaced shortly. The 1.20 value is the actual pressure drop in inches W.C. across the filter.



The third bar indicates the amount the Box Filter that has been used. The red color indicates that the filter has run out of life and at this point the fan will shut down. In this case the Box Filter has about 0% usage left. The 1.50 value is the actual pressure drop in inches W.C. across the filter.



Filter Clogged Message

Once a filter has reached the end of its life, a signal is sent back to the Touchscreen, the Message screen is shown and KES will turn off.

Touch anywhere on the screen to return to the **Dashboard** window.

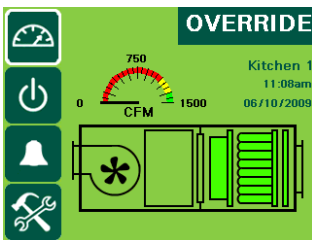

If this condition occurs during a busy period when filters cannot be changed, *Touch* the **OVERRIDE** button and the KES will turn back on.

Engaging the override option will begin a count-down and the KES will run for 4 hours before shutting down again.

The filters must be changed and the system reset.

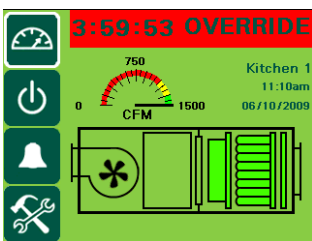

Recording filter changes on the attached filter usage chart (see page 24) will help you prevent having to run in override. Using this chart a regular maintenance schedule can be set up to ensure constant uninterrupted operation of the commercial kitchen.

Filter Removed Message

Should the bag or box filters be removed during normal operation, the KES unit is automatically shutdown. The message screen appears and the Diagnostic Screen will indicate "FILTER REMOVED/LOW EXHAUST". To resume normal operation the filter must be replaced and the system reset.

The system cannot be operated or turned to **OVERRIDE** with a filter removed.

High Temperature Message

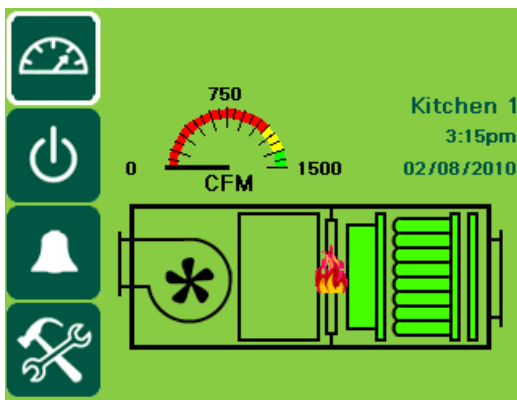

In the event of a high temperature in the inlet to the KES-ISH filter unit a high temperature stat located at the inlet of the KES-ISH filter section is activated. When the exhaust air reaches 160 F the high temperature stat is energized. The exhaust fan shuts off, the message screen appears and the Diagnostic Screen will indicate "High temperature in the KES". Should the KES exhaust temperature continue to rise the fusible link melts in the KES-ISH filter section discharge and closes the fire damper in the exhaust. This fire damper is always located between the fan and filter section. The fire damper fusible link is rated at 165 F. Shut off all cooking equipment and notify the fire department. To resume normal operation, replace the fusible link and reset the system. An authorized SPRING AIR SYSTEM INC. service technician should be called to inspect the unit.

Surface Fire Message

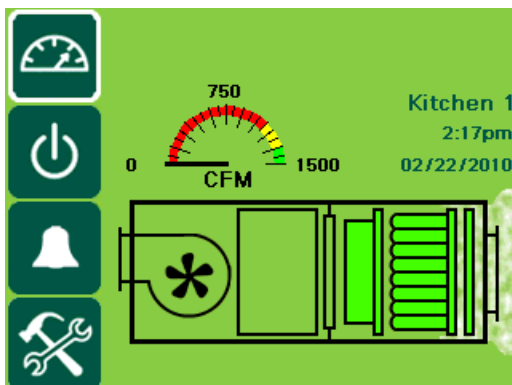

In the event the surface fire suppression system activates, the KES unit will display as shown to the left.

To resume normal operation, the fire suppression system and KES unit will need to be reset.

Determine the Filter Change Schedule

The Prefilter, Bag filter and Box filter must be changed on a regular basis to maintain the high grease extraction efficiency required by the UL/ULC listing. Once a red filter clogged light comes on the filter has reached its grease/particulate holding capacity. Further use will restrict exhaust air flow causing hood smoke capture problems and/or cause the clogged filter to blow out into the next filter or the exhaust fan. Therefore the three particulate filters must be changed when the red Filter Clogged lights activates. This will provide simple uninterrupted operation for your commercial kitchen operation.

These steps can be used to determine an approximate date to change filters.

1. Operate the unit until the filter icon turns red.
2. Change the filter at the end of the shift or the next day before cooking.
3. Write that date under Filter Change No. 1 / Actual for the filter that was changed.
4. Count the number of days between the Startup Date and the first filter change date.
5. Count forward that number of days from the first filter change date.
6. Record that date under Filter Change No. 2 / Scheduled
7. If the filter icon turns red prior to the scheduled filter change date, change the filter at that time and re-count the days for the next scheduled change date.

EXAMPLE

KES unit was started up on June 1st and the pre-filter icon turned red on June 25th. This is 24 days. The Filter Change No. 2 / Scheduled should be written down as July 19th.

FILTER FREQUENCY CHART						
Startup date/First Prefilter change						
Change No.	Prefilter		Bag Filter		Box Filter	
	Schedule	Actual	Schedule	Actual	Schedule	Actual
1						
2						
3						
4						
5						
6						
7						
8						
9						
10						
11						
12						
13						
14						
15						
16						
17						
18						
19						
20						
21						
22						
23						
24						

WHERE TO PURCHASE FILTERS:

Spring Air Systems Inc.

1388 Cornwall Rd., Oakville Ont., L6J 7W5
(905) 338-2999

Airguard Industries

125 Buttermill Rd., Concord, Ontario, L4K 3X5
905-669-9876

Airguard Corp.

4806 Strong Rd., Crystal Lake, IL, 60014
888-324-5665

Camfil Farr Filters

67 Steepecase Rd. W., Markham Ont., L3R 2M4
(905) 415-3030

Camfil Farr

2201 Park Place, El Segundo, CA, 90245
310-727-6300

RECOMMENDATION

TO ENSURE TROUBLE FREE OPERATION FOR YOUR KITCHEN EXHAUST SYSTEM A PROPER PREVENTATIVE MAINTENANCE PROGRAM IS A NECESSITY.

SPRING AIR SYSTEMS RECOMMENDS THAT A YEARLY SERVICE CONTRACT BE SET UP WITH A REPUTABLE SERVICE ORGANIZATION. THIS WILL REDUCE UNEXPECTED DOWN TIME TO A MINIMUM.

REPLACEMENT FILTER EQUIVALENTS

PREFILTERS: MERV7 (30% ASHRAE 52-76) - ULC Class II

Airguard: 24" x 24" x 2" - DP40 Class II
12" x 24" x 2" - DP40 Class II

American Air Filter:

24" x 24" x 2" - AM-AIR Class II
12" x 24" x 2" - AM-AIR Class II

Farr Filters: 24" x 24" x 2" - 30% ASHRAE 52-76 Class II
12" x 24" x 2" - 30% ASHRAE 52-76 Class II

BAG FILTERS: MERV13 (90 - 95% ASHRAE 52 - 76) - ULC Class II

Airguard: 24" x 24" x 22" - V9-4M Class II
12" x 24" x 22" - V9-4M Class II

American Air Filter:

24" x 24" x 21" - DRI-PAK - Class II
12" x 24" x 21" - DRI-PAK - Class II

Farr Filters: 24" x 24" x 22" - 90% ASHRAE 52-76 Class II
12" x 24" x 22" - 90% ASHRAE 52-76 Class II

BOX FILTERS: MERV16 (95% DOP/99% ASHRAE 52-76) ULC Class II

Airguard: 24" x 24" x 12" - VMB- 904 Class II
12" x 24" x 12" - VMB-904 Class II

American Air Filter:

24" x 24" x 12" - BIOCELL Class II
12" x 24" x 12" - BIOCELL Class II

Farr Filter:

24" x 24" x 12" - 6 pocket - 95% DOP Class II
12" x 24" x 12" - 6 pocket - 95% DOP Class II

ODOR MEDIA: 1/8" Activated alumina pellets impregnated with potassium permanganate.

Airguard: Barneby-Cheney CP-2

American Air Filter:

Permasorb

Farr Filters:

Unisorb.

Odor Spray: Spring Fresh, Spring Air Systems

KES MAINTENANCE SCHEDULE

Every two weeks:

1. Check the prefilter pressure reading. If the prefilter bar graph is red replace the prefilter. It is very important to maintain clean prefilter(s). Replacing the inexpensive prefilter(s) often extends the life of the bag and box filters and reduces unnecessary down time due to clogged filter shutdowns. *The Touchscreen panel will indicate separately when the “prefilter”, “bag” and “box” filters are clogged. When this occurs the unit shuts down. Touch the override button to energize the system for another 4 hours. This provides time to change the filters after the day of cooking is complete. This is a final dirty filter alarm after the red dirty filter warning. Once the approximate filter life for your application is determined we recommend that a regular filter change schedule be set up before the filter clog activates.*

Every Month:

1. Complete the two-week list.
2. Inspect the exhaust fan belt for correct tension and wear. All belts usually require adjustment at this time. Failure to tighten may result in the belt falling off and no airflow.
3. Check the bag filter (2nd stage filtration) pressure reading. If the bag filter bar graph is red replace the bag filter. The life of the bag filter depends on the type of cooking equipment and exhaust hood system. For heavy cooking applications the bag filters may require replacement every month.
4. **(Odor Spray Option)** Inspect the odor spray bottle. Refill if necessary. *At startup the odor spray is adjusted to the desired level. The amount of odor spray used varies with this initial setting. It is important to inspect the level in the bottle every two weeks until the normal rate of use is determined.*

Every Three Months:

1. Complete the two-week and monthly checklist.
2. Inspect the exhaust fan belt for correct tension and wear. Adjust if necessary.
3. Check the box filter (3rd stage filtration) pressure reading. If the box filter bar graph is red replace the box filter. Once again the life of the box filter depends on the type of cooking equipment and exhaust hood system. The box filter may provide one year of service on most applications with high efficiency water wash ventilators.
4. Inspect all electrical connections. Tighten if necessary.
5. Test the filter-removed circuit. Open the prefilter access door while the KES unit is in operation. The unit should shut down and indicate a filter-removed condition.

Every Six Months:

1. Complete the two-week, monthly and three month check list.
2. Open the fan wheel access door or hatch on the KES fan section. Inspect the fan wheel for grease build up. Clean as required.
3. Inspect the exhaust inlet fire damper and fusible link. Replace link annually.
4. Check the motor and fan bearings for noise or overheating. STY and FYC bearings are factory pre-lubricated lifetime sealed and require no further lubrication. SY and FY bearings are pre-lubricated and equipped with pressure grease fittings for re-greasing. Under normal service conditions grease after six months of operation.
5. **(Odor Pellet Option)** Inspect the condition of odor media.
6. The odor media pellets can be checked for remaining life by sending a sample to an accredited test laboratory. Most major filter suppliers have access to such service. Replace media if required. To replace the media remove the cells from the KES unit. Open the side panel on each odor cell and pour out the used media. Refill the cells with new media. Shake cells while filling to allow pellets to settle evenly in the cell. **Note:** *Do not allow odor media to come in contact with water, as this will immediately render the pellets useless.*

Every Year:

1. Complete the two-week, monthly, three month and six month check list.
2. Check if KESF fan motor is running hotter than normal. If the motor running hot check the operating AMPS of the motor.
3. Make sure the KESF fan wheel rotates freely before startup. Inspect and clean the wheel periodically. If dirt is allowed to build up the wheel could become out of balance and cause premature bearing wear.

Fan Bearings

1. STY and FYC bearings are factory pre-lubricated lifetime sealed and require no further lubrication.
2. SY and FY bearings are pre-lubricated and equipped with pressure grease fittings for re-greasing.
3. Under normal service conditions grease after three to six months of operation.

Motor Bearings:

1. All motors leave the factory with bearings custom greased for many years of service under most conditions.
2. Re-greasing of motors depends on the application and is best left to trained service technicians.
3. Periodically check if motor is running hotter than normal.

Centrifugal Exhaust Fan:

1. Make sure the wheel rotates freely before startup.
2. Inspect and clean the wheel periodically.
3. If dirt is allowed to build up the wheel could become out of balance and cause premature bearing wear.
4. A noisy fan is a typical sign of a fan out of balance.

V-Belt Drives:

1. ALWAYS KEEP SPARE SET OF BELTS. Periodically check the belt tension and adjust if necessary.
2. Some slack should be left in the belt, typically 1/4" per foot of belt from the fan to the motor sheave.
3. Always replace the complete set of belts to ensure even tension and wear. When replacing belts loosen the motor mounts.
4. Do not force belts over sheaves.

RECOMMENDATION

TO ENSURE TROUBLE FREE OPERATION FOR YOUR KITCHEN EXHAUST SYSTEM A PROPER PREVENTATIVE MAINTENANCE PROGRAM IS NECESSARY. SPRING AIR RECOMMENDS THAT A YEARLY SERVICE CONTRACT BE SET UP WITH A REPUTABLE SERVICE ORGANIZATION. THIS WILL REDUCE UNEXPECTED DOWN TIME TO A MINIMUM.

Troubleshooting

I. **Low Exhaust Air**

1. **Exhaust fan is running but exhaust air is low.**

- a) Check if fan belts are slipping. Tighten if necessary.
- b) Check if fusible link fire damper has closed in the KES filter section. Replace fusible link.
- c) Check if filters are dirty but have not indicated any filter clogged... Check if all the filters are in the yellow. Replace prefilter first and check air flow on screen dirty filters.
- d) Check for correct fan rotation. On MXFLOW units to correct fan rotation switch two of the high voltage wires on terminals V/T1, U/T2 or W/T3 on the drive.

II. **Red Filter Clogged Message.**

1. Filter clogged message indicates which filter section has plugged. Replace filter and reset system on the screen.
2. If the filter clogged activates earlier than the normal established check the actual operating pressure vs. the FILTER CLOGGED pressure setting for each of the filters from the Truflow screen. Adjust the pressure setting at the screen as required. .
3. If adjusting the pressure settings is not effective and the amount/usage of the kitchen has not increased check the recommended filter clogged limits from the filter manufacturer.

III. **Filter Out Message.**

1. A filter has been removed or access door left open. Replace if necessary.
2. Check if fusible link fire damper has closed in the KES filter section. Replace fusible link.
3. All filters may be closed to sending a clogged message. Change the prefilter first. If the filter out message does not reset change the bag filters. **NEVER CHANGE ALL FILTERS AT THE SAME TIME. THIS IS A WASTE OF MONEY.**

V. **High Temperature Message.**

1. The high temperature stat in the KES filter section exhaust outlet has activated and shut the KES system down. If a high temperature is not present check calibration of high temperature stat TH1. High temperature stat is set at 160F.
2. Check if fusible link fire damper has closed in the KES filter section. Replace fusible link.

Checking Fan Rotation

Fan rotation should be checked prior to commission the system. The backward inclined KESF fan must be running backwards such that the fan blades pushing the air from the back of the blade. If the fan is scooping the air change the fan rotation. To correct fan rotation switch two of the high voltage wires on terminals V/T1, U/T2 or W/T3 on the drive or switch two wires at the motor.

SHUT OF ALL POWER TO THE KESF BEFORE CORRECTING ROTATION



A KESF DWDI fan. Correct rotation for this fan arrangement looking into the end shown above is clockwise

Common MXFlow Touchscreen Messages

- a) Drive(x) Motor Overload/Over-speed fault. Motor overload setting incorrect or RPM too high.
- b) Drive(x) Exhaust over-current fault. Running motor amp too high.
- c) Drive(x) Impending Short Circuit. Possible dead short at fan(x) motor soon.
- d) Drive(x) Motor short circuit fault to earth. Dead short at fan(x) motor
- e) Drive(x) Line supply over-voltage fault. Input voltage source to drive too high.
- f) Drive(x) Line under-voltage fault. Input voltage source to drive too low.
- g) Drive(x) Supply phase loss fault. Input voltage source to drive has lost a phase.
- h) Drive(x) Drive over-heating fault. Drive(x) is overheating. Shut off fan.
- i) Drive(x) Internal Fault. Drive(x) has internal fault that will not allow drive(x) to operate from Touchscreen panel.
- j) Drive(x) Modbus Communication fault. Drive(x) connected to the TruFlow is not communicating with TruFlow.
- k) Drive(x) External Fault. Drive(x) is faulty.
- l) Drive(x) Brake control fault. Possible exhaust fan problem.
- m) Drive(x) Drive voltage disabled. Not input voltage source to Drive(x).
- n) Drive(x) Drive configuration invalid. Drive(x) has lost factory drive configuration.
- o) Surface Fire. The surface fire suppression system has activated.
- p) COMM(x) Fault: Drive(x) has no communication. Drive(x) CAT5 is probably connected to TruFlow.
- q) COMM2 Port Error: The CAT5 to all drives is not connected to the MxFlow.

Drive Messages:

- a) Drive in SLF state: Drive(x) is not communicating with the TruFlow.
- b) Drive in NST state: Drive(x) is communicating but no information is being send by TruFlow.

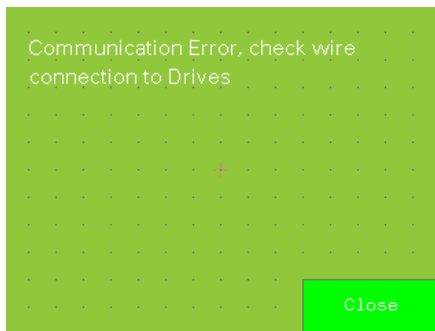

Communication Error Screen

Typical message displayed on diagnostic screen after Modbus, Comm Port or Comm fault.



Surface Fire Suppression Reset

Typical message displayed on Dashboard screen after surface fire suppression activates.

APPENDIX

A. SETTING THE DMP (PXR) Controller for Pressure Transducer

	Set Point (SV parameter) - Setting the set point
SV=total static pressure	Touch SEL once. Use V and Λ to adjust the project set point. Touch SEL. The factory setting is the total static pressure indicated on the KESF unit drawings" W.C. (Total static pressure)

PXR3 Micro-controller: Factory setup

Power the MXFLOW panel and proceed to input the following setting.

	2nd Block Parameters
	Touch SEL and hold for about 3 seconds until P appears on the display. Release SEL.
P=17	Touch SEL again to set the Proportional Band. Use the Λ to increase parameter set value and V to decrease parameter set value. Set P = 17 and then touch SEL.
I=12	Touch V to next parameter, integral time, I. Touch SEL and set value to 12. Touch SEL
d=3.3	Touch V to next parameter, derivative action time, d. Touch SEL and set value to 3.3. Touch SEL.
hys=0	Touch V to next parameter, hysteresis, hys. Touch SEL and set value to 0. Touch SEL
CTrL=PID	Touch V three times to next parameter, Control algorithm, CTrL. Touch SEL and check that the setting is PID. If is not us the V and Λ to set to PID and then touch SEL.
P-n2=16	Touch V three times to next parameter, input type code, P-n2. Touch SEL and adjust setting to 16. Touch SEL.
P-SL=0	Touch V to next parameter, Lower limit of input range, P-SL. Touch SEL and adjust setting to 0. Touch SEL.
P-SU=500	Touch V to next parameter, Upper limit of input range, P-SU. Touch SEL and adjust setting to 500. Touch SEL.
P-dF=20	Touch V twice to next parameter, Time constant of input firtev. Touch SEL and adjust setting to 20. Touch SEL.
	Touch SEL and hold for about 2 seconds to return to set point.

	3rd Block Parameters
	Touch SEL and hold for about 5 seconds until P-n1 appears on the display. Release SEL.
P-n1=1	Touch SEL again to set the Control Action, P-n1. Use the Λ and V to adjust the value to 1. Touch SEL.
SV-L=0	Touch V to next parameter, Lower limit of SV, SV-L. Touch SEL and adjust setting to 0. Touch SEL.
SV-H=5.0	Touch V to next parameter, Upper limit of SV, SV-H. Touch SEL and adjust setting to 5.0. Touch SEL.
	Touch SEL and hold for about 2 seconds to return to set point.



	1st Block Parameters
	Touch SEL and hold for about 1 second until STbY appears on the display. (or LACH)
AT=1	AUTOTUNING Touch V until AT appears on display. Touch SEL and set the Auto-tuning to 1. using V and Λ. Touch SEL.
LOC=2	Locks the parameter values

After re-programming any value **Autotune** the controller again.

B. PXR Sensor Fault Operation

[8] Sensor fault operation

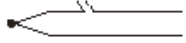
• Thermocouple

Condition		Display	Control output
Break			ON or more than 20mA (Note) OFF or less than 4mA
Short circuit		short-circuit point Temperature display	Input is controlled as short-circuit point (Note) temperature.

• 4-20mA DC

Over-range		OFF or less than 4mA (Note)
Under-range		ON or more than 20mA

C. FACTORY DRIVE TERMINAL SCHEMATIC

Wiring Diagram for Factory Settings

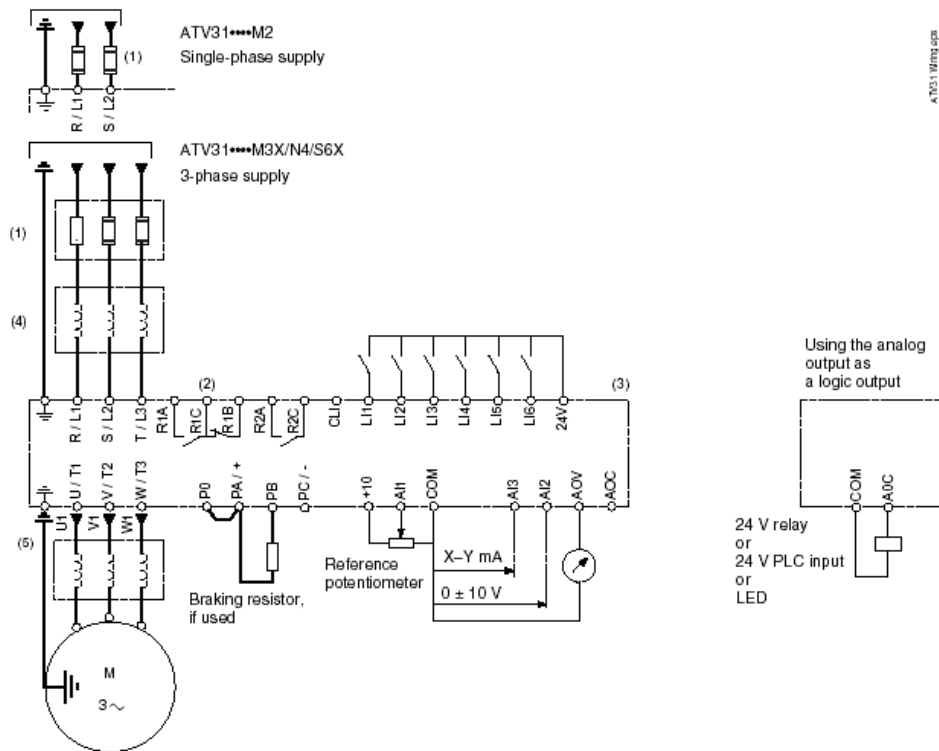

NOTE: The line supply terminals are shown at the top and the motor terminals are shown at the bottom. Connect the power terminals before connecting the control terminals. Install surge suppressors on all inductive circuits located near the drive controller or coupled to the same circuit.

- (1) Refer to the drive controller nameplate or to the tables on pages 34–35 for recommended fuses. Fast acting or time delay Class J fuses can be used.
- (2) Fault relay contacts for remote indication of drive controller status.
- (3) Internal +24 V. If an external source is used (30 V max.), connect the 0 V terminal of the source to the 0 V (COM) terminal, and do not use the +24 V terminal on the drive controller for any purpose.
- (4) Line reactor, if used. All 575 V installations must include a line reactor. See page 21.
- (5) Installation of a load filter is recommended for all 575 V applications. See page 22.

D. LOGIC INPUT SWITCH

The logic input switch assigns the logic input common link to 0 V (Source logic), 24 V (Sink logic), or floating.

NOTE: When the logic input is configured for Sink logic, grounding the input signals can result in unintended activation of drive controller functions.

⚠ DANGER

UNINTENDED EQUIPMENT OPERATION

- Protect the signal conductors against damage that could result in unintentional conductor grounding.
- Follow NFPA 79 and EN 60204 guidelines for proper control circuit grounding practices.

Failure to follow these instructions can result in death, serious injury, or equipment damage.

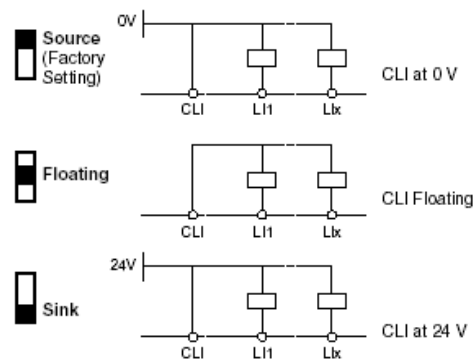

AT028 Logic Input Switch.jpg

E. DRIVE TECHNICAL SPECIFICATIONS FOR LOCATING DRIVE PANELS

Table 2: Environment

Degree of Protection	<ul style="list-style-type: none"> • IP20 without protective vent cover, NEMA 1, UL open type. • IP21 on wiring terminals • IP31 and IP41 all other areas • UL Type 1 without removal of the protective vent cover from the top of the controller and with the addition of the Conduit Entry Kit (see page 14).
Resistance to vibrations	Conforming to IEC/EN 60068-2-6: 1.5 mm peak to peak from 3 to 13 Hz, 1 gn from 13 to 150 Hz
Resistance to shocks	15 gn for 11 ms conforming to IEC/EN 60068-2-27
Pollution degree	Pollution degree 2 according to UL 940. Protect the drive controller against dust, corrosive gas, and falling liquid.
Maximum relative humidity	96% maximum, non-condensing and without dripping (provide heating system if there is condensation) Conforms to IEC 60068-2-3
Maximum ambient temperature	Storage: -13 to +158 °F (-25 to +70 °C) Operation: +14 to +122 °F (-10 to +50 °C) without vent cover removed and without derating +14 to +140 °F (-10 to +60 °C) with vent cover removed and with derating. Refer to derating curves on page 15.
Altitude	Up to 3,300 ft (1,000 m) without derating; derate by 1% for each additional 330 ft (100 m)

F. HAZARDOUS WARNING

DANGER

HAZARDOUS VOLTAGE

- Read and understand this manual before installing or operating the Altivar 31 drive controller. Installation, adjustment, repair, and maintenance must be performed by qualified personnel.
- For more information on Altivar 31 drive controllers, see the *Altivar 31 Start-Up Guide*, VVDED303043US, and the *Altivar 31 Programming Manual*, VVDED303042US. Both manuals are shipped with the drive controller. They are also available from www.us.SquareD.com or from your Schneider Electric representative.
- The user is responsible for conforming to all applicable code requirements with respect to grounding all equipment.
- Many parts in this drive controller, including printed wiring boards, operate at line voltage. DO NOT TOUCH. Use only electrically insulated tools.
- DO NOT touch unshielded components or terminal strip screw connections with voltage present.
- DO NOT short across terminals PA and PC or across the DC bus capacitors.
- Install and close all covers before applying power or starting and stopping the drive controller.
- Before servicing the drive controller:
 - Disconnect all power.
 - Place a "DO NOT TURN ON" label on the drive controller disconnect.
 - Lock the disconnect in the open position.
- Disconnect all power including external control power that may be present before servicing the drive controller. WAIT 3 MINUTES for the DC bus capacitors to discharge. Then follow the DC bus voltage measurement procedure on page 20 to verify that the DC voltage is less than 45 Vdc. The drive controller LEDs are not accurate indicators of the absence of DC bus voltage.

Electric shock will result in death or serious injury.

G. GOOD WIRING PRACTICE

Good wiring practice requires the separation of control circuit wiring from all power (line) wiring. In addition, power wiring to the motor must have the maximum possible separation from all other power wiring, whether from the same drive controller or other drive controllers; **do not run in the same conduit**. This separation reduces the possibility of coupling electrical transients from power circuits into control circuits or from motor power wiring into other power circuits.

CAUTION

IMPROPER WIRING PRACTICES

- Follow the wiring practices described in this document in addition to those already required by the National Electrical Code and local electrical codes.
- The drive controller will be damaged if input line voltage is applied to the output terminals (U, V, W).
- Check the power connections before energizing the drive controller.
- If replacing another drive controller, verify that all wiring connections to the ATV31 drive controller comply with all wiring instructions in this manual.

Failure to follow this instruction can result in injury or equipment damage.

Follow the practices below when wiring ATV31 drive controllers:

- Verify that the voltage and frequency of the input supply line and the voltage, frequency, and current of the motor match the rating on the drive controller nameplate.
- Use metallic conduit for all drive controller wiring. Do not run control and power wiring in the same conduit.
- Separate the metallic conduits carrying power wiring from those carrying control wiring by at least 76 mm (3 in.).

- Separate the non-metallic conduits or cable trays used to carry power wiring from the metallic conduit carrying control wiring by at least 305 mm (12 in.).
- Whenever power and control wiring cross, the metallic conduits and non-metallic conduits or trays must cross at right angles.
- Equip all inductive circuits near the drive controller (such as relays, contactors, and solenoid valves) with noise suppressors, or connect them to a separate circuit.

H. GROUNDING

Ground the drive controller according to the National Electrical Code and all local codes to ensure safe, dependable operation. To ground the drive controller:

- Connect a copper wire from the equipment ground lug or terminal to the power system ground conductor. Size the wire according to the drive controller rating and national and local codes.
- Verify that resistance to ground is one ohm or less. Improper grounding causes intermittent and unreliable operation.

⚠ DANGER

HAZARDOUS VOLTAGE

Ground equipment using the provided ground connecting point as shown in the figure below. The drive controller panel must be properly grounded before power is applied.

Electric shock will result in death or serious injury.

Ground multiple drive controllers as shown in the figure below. Do not loop the ground cables or connect them in series.

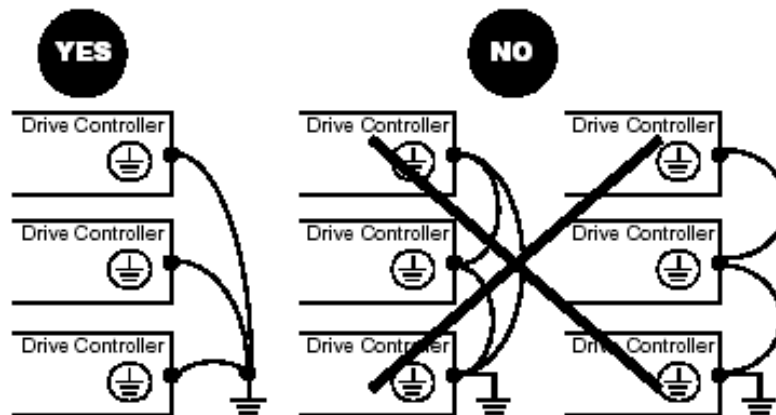

I. MANUALLY STARTING THE DRIVE

ATV31..... Controllers

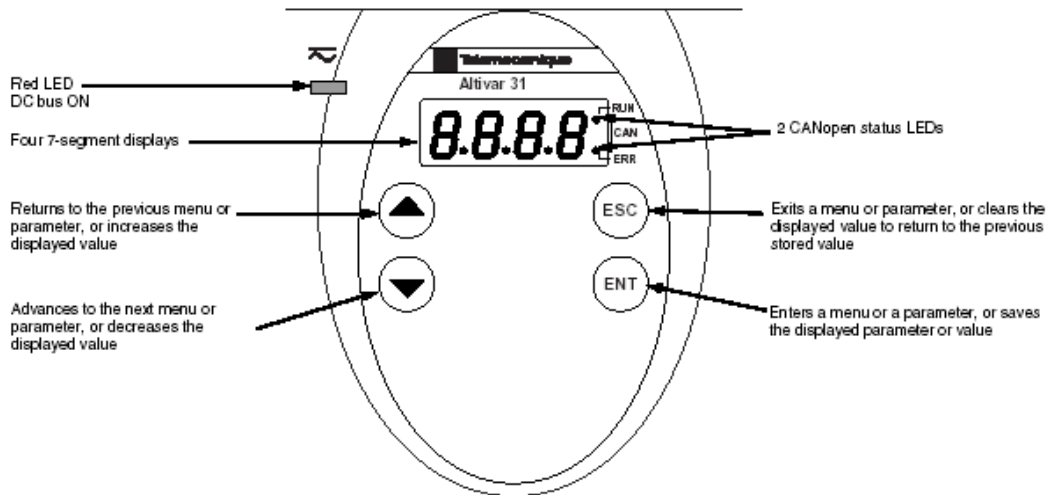

- Press and hold down (longer than 2 seconds) the ▲ or ▼ keys to scroll through the data quickly.
- Pressing ▲ or ▼ does not store the selection.
- To store the selection, press the ENT key. The display flashes when a value is stored.

A normal display with no fault present and no run command shows:

- The value of one of the display parameters (see page 80). The default display is motor frequency, for example 43.0. In current limiting mode, the display flashes.
- init: Initialization sequence
- rdY: Drive ready
- dcb: DC injection braking in progress
- nSt: Freewheel stop
- FSt: Fast stop
- tUn: Auto-tuning in progress

If a fault is present, the display flashes.

J. ACCESSING THE DRIVE PROGRAM MENU

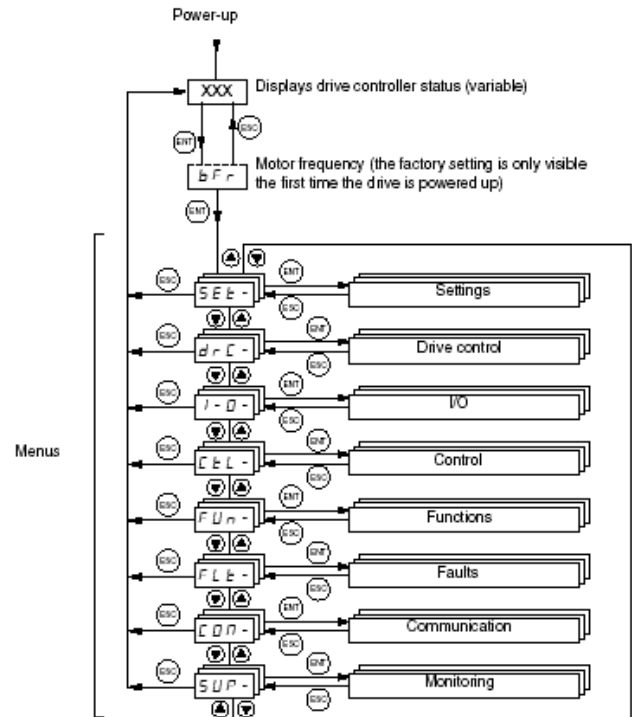

The following figure illustrates how to access parameters and assign their values. To store the parameter value, press the ENT key. The display flashes when a value is stored.

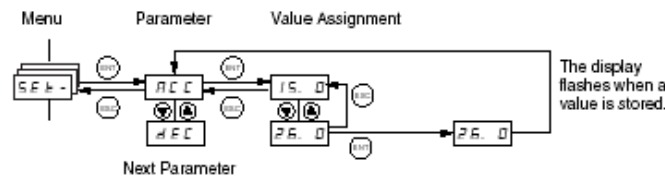

All of the menus are drop-down type menus. Once you have reached the last parameter in a list, press the ▼ key to return to the first parameter. From the first parameter in the list, press the ▲ key to jump to the last parameter.

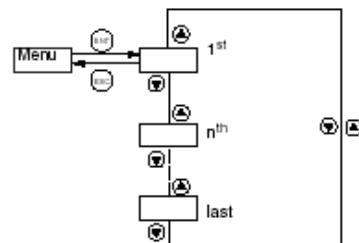

If you have modified a parameter in a menu and you return to that menu without accessing another menu in the meantime, you will be taken directly to the parameter you last modified. See the illustration below. If you have accessed another menu or have restarted the drive controller since the modification, you will be taken to the first parameter in the menu. See the illustration above.

K. PROGRAMMING THE DRIVE PARAMETERS

MXFLOW Parameter Setting on Drive

NOTES:

If blinking **SLF** appears on screen then recycle the power.

 Touch to select until the screen blinks. If drive value is already desired value then screen will not blink upon reselection.



nSt

1. Touch if appears on screen.



dr [-

2. Touch until appears on screen.



3. Touch



bFr

4. Touch until appears.



5. Touch



6. Touch or to obtain 60.0.



7. Touch



8. Touch

9. Touch



until

nCr

appears on screen.



10. Touch



11. Touch **FLA** or until appears.



12. Touch



13. Touch



14. Touch or *t U n* until appears.



15. Touch



P O n

16. Touch until appears.



17. Touch



18. Touch



t F r

19. Touch until appears.



20. Touch



21. Touch or to obtain 72.0.



22. Touch



23. Touch



24. Touch



25. Touch until appears.

S E t -



26. Touch



A C C

27. Touch until appears.



28. Touch or to obtain 10.0.



29. Touch



d E C























30. Touch until appears.



31. Touch



32. Touch or to obtain 10.0.

-  33. Touch
-  34. Touch
-  *L S P* 35. Touch until appears.
-  36. Touch
-   37. Touch or to obtain 45.0.
-  38. Touch
-  39. Touch
-   *H S P* 40. Touch or until appears.
-  41. Touch
-   42. Touch or to obtain 65.0.
-  43. Touch
-  44. Touch
-  *t t d* 45. Touch until appears.
-  46. Touch
-  47. Touch to obtain 118.
-  48. Touch
-  49. Touch
-  50. Touch
-  *C E L -* 51. Touch until appears.
-  52. Touch



F r l

53. Touch until appears.



54. Touch



A l 3

55. Touch or until appears.



56. Touch and HOLD until the screen blinks.



57. Touch



L A C

58. Touch or until appears.



59. Touch



60. Touch *L 3*

or until appears.



61. Touch and HOLD until the screen blinks.



62. Touch



63. Touch



l - 0 -

64. Touch until appears.



65. Touch



r r 5

66. Touch until appears.



67. Touch



n 0

68. Touch or until appears.



69. Touch



70. Touch



[r L 3

71. Touch or until appears.



72. Touch



73. Touch or to obtain 4.0.



74. Touch



75. Touch



C r H E

76. Touch or until appears.



77. Touch



78. Touch or to obtain 20.0.



79. Touch



80. Touch



81. Touch until appears.

r l



82. Touch



r U n

83. Touch or until appears.



84. Touch



























85. Touch





86. Touch until appears.

A O I E

-  87. Touch
- 

4 A 88. Touch or until appears.
-  89. Touch
-  90. Touch
-  91. Touch until appears.
 d 0
-  92. Touch
- 

0 F r 93. Touch or until appears.
-  94. Touch
-  95. Touch
-  96. Touch
-  97. Touch until appears.
 F U n -
-  98. Touch
- 
S A 1 - 99. Touch until appears.
-  100. Touch
- 

S A 2 101. Touch or until appears.
-  102. Touch
- 

n 0 103. Touch or until appears.
-  104. Touch
-  105. Touch
- 
S A 3 106. Touch until appears.
- 

107. Touch

  *n 0* 108. Touch or until appears.

 109. Touch



 110. Touch

 111. Touch



 112. Touch

 113. Touch until appears. *FL E -*

 114. Touch

  *AL r* 115. Touch or until appears.

 116. Touch

  *YES* 117. Touch or until appears.

 118. Touch

 119. Touch

 *dr n* 120. Touch until appears.

 121. Touch

 122. Touch until appears. *YES*

 123. Touch and HOLD until screen blinks.

 124. Touch

 *0 PL* 125. Touch until appears.

 126. Touch

  *n 0*
KES Touchscreen Maintenance Manual June 2010

127. Touch or until appears.



128. Touch



129. Touch



130. Touch until appears.

L F L



131. Touch



L F F

132. Touch or until appears.



133. Touch



134. Touch



135. Touch or until appears.

L F F



136. Touch



137. Touch or to obtain 60.0.



138. Touch







n 5 t

139. Touch until appears.

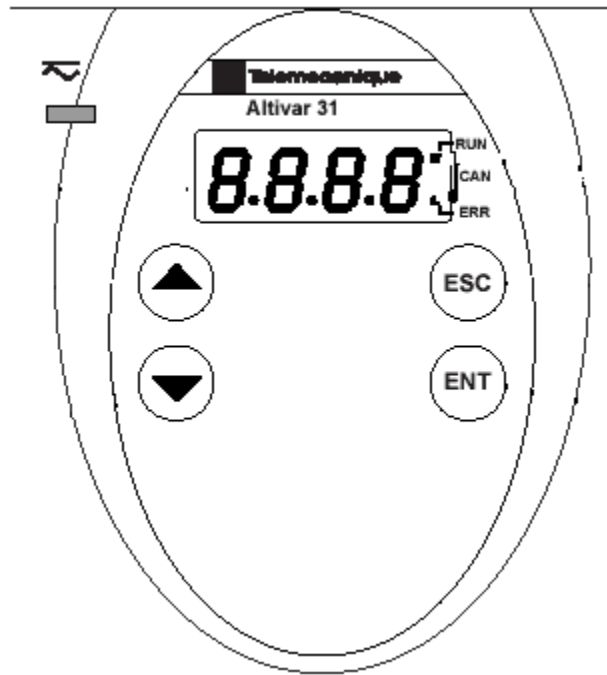
L. Drive Factory Reset

Drive Key Pad Display



-  Scroll up OR increase numerical value
-  Scroll down OR decrease numerical value
-  Explore directory OR Select
-  Exit directory / Go back

Resetting the Drive to Factory Setting

Notes:

Ensure that the motor is NOT running while performing this operation.

1) Read the screen.

a. *S L F* then recycle the power

b. *n S t* touch 

 *d r [-* 2) Touch until *d r [-* appears on screen.

 3) Touch

 *F C S* 4) Touch until *F C S* appears on screen.

 5) Touch

 *I n I* 6) Touch until *I n I* appears on screen.

 7) Touch and HOLD until the screen *n 0* blinks and appears.

 *n S t* 8) Touch until *n S t* is on screen.

M. TROUBLE SHOOTING AND DRIVE FAULT DISPLAY

PRECAUTIONS

Read the following safety statements before proceeding with any maintenance or troubleshooting procedures.

DANGER

HAZARDOUS VOLTAGE

- Disconnect all power before servicing the drive controller.
- Read and understand these procedure and the precaution on page 13 of this manual before servicing the ATV31 drive controllers.
- Installation, adjustment, and maintenance of these drive controllers must be performed by qualified personnel.

Failure to follow this instruction will result in death or serious injury.

ROUTINE MAINTENANCE

Perform the following steps at regular intervals:

- Check the condition and tightness of the connections.
- Make sure that the ventilation is effective and that the temperature around the drive controller remains at an acceptable level.
- Remove dust and debris from the drive controller, if necessary.

FAULT DISPLAY

If a problem arises during setup or operation, ensure that all ambient environment, mounting, and connection recommendations have been followed.

The first fault detected is stored and displayed, flashing, on the screen. The drive controller locks and the fault relay (RA-RC) contact opens, if it has been configured for this function.

Drive Controller Does Not Start, No Fault Displayed

If the drive controller will not start and there is no display indication, consider the following:

1. Check the power supply to the drive controller.
2. The assignment of the fast stop or freewheel stop functions prevents the drive controller from starting if the corresponding logic inputs are not powered up. In this case, the drive controller displays nSt in freewheel stop mode and FSt in fast mode. This is normal, since these functions are active at zero speed so that the drive controller will stop safely if there is a wire break.
3. Ensure that the run command inputs have been actuated in accordance with the chosen control mode (ICC parameter in the I-O- menu. See page 29).
4. If an input is assigned to the limit switch function and this input is at state 0, the drive controller can only be started by sending a command for the opposite direction (see page 72).
5. If the reference channel (page 37) or the control channel (page 38) is assigned to Modbus or CANopen, the drive controller displays nSt on power up and remains stopped until the communication bus sends a command.

TROUBLESHOOTING

Fault Display

If a problem occurs during setup or operation, ensure that all ambient environment, mounting, and connection recommendations have been followed.

The first fault detected is stored and displayed, flashing, on the screen. The drive controller locks and the fault relay (R1A-R1C or R2A-R2C) contact opens.

Drive Controller Does Not Start, No Display

If the drive controller will not start and there is no display indication, check the power supply to the drive controller. Refer to the *ATV31 Programming Manual* for more troubleshooting information.

Faults Which Cannot be Automatically Reset

Faults which cannot be automatically reset are listed in the table beginning on page 44. To clear these faults:

1. Remove power from the drive controller.
2. Wait for the display to go off completely.
3. Determine the cause of the fault and correct it.
4. Reapply power.

CrF, SOF, tnF, bLF, and OPF can also be reset remotely via a logic input (rSF parameter in the FLT-menu, see the *ATV31 Programming Manual*).

Faults Which Cannot be Automatically Reset

Fault	Probable Cause	Remedy
bLF Brake sequence	Brake release current not reached	<ul style="list-style-type: none"> • Check the drive controller and motor connections. • Check the motor windings. • Check the lbr setting in the FUn-menu. Refer to the <i>ATV31 Programming Manual</i>.
CrF Precharge circuit fault	Precharge circuit damaged	<ul style="list-style-type: none"> • Reset the drive controller. • Replace the drive controller.
tnF Internal fault	<ul style="list-style-type: none"> • Internal fault • Internal connection fault 	<ul style="list-style-type: none"> • Remove sources of electromagnetic interference. • Replace the drive controller.
OPF Overcurrent	<ul style="list-style-type: none"> • Incorrect parameter settings in the SEt- and drC- menus • Acceleration too rapid • Drive controller and/or motor undersized for load • Mechanical blockage 	<ul style="list-style-type: none"> • Check the SEt- and drC- parameters. • Ensure that the size of the motor and drive controller is sufficient for the load. • Clear the mechanical blockage.
SCF Motor short circuit	<ul style="list-style-type: none"> • Short circuit or grounding at the drive controller output • Significant ground leakage current at the drive controller output if several motors are connected in parallel 	<ul style="list-style-type: none"> • Check the cables connecting the drive controller to the motor, and check the motor insulation. • Reduce the switching frequency. • Connect output filters in series with the motor.
SOF Overspeed	<ul style="list-style-type: none"> • Instability • Overhauling load 	<ul style="list-style-type: none"> • Check the motor, gain, and stability parameters. • Add a braking resistor. • Check the size of the motor, drive controller, and load.
tnF Auto-tuning fault	<ul style="list-style-type: none"> • Motor or motor power not suitable for the drive controller • Motor not connected to the drive controller 	<ul style="list-style-type: none"> • Use the L or the P ratio (see UFT on page 36). • Check the presence of the motor during auto-tuning. • If a downstream contactor is being used, close it during auto-tuning.

Faults Which Can be Reset With the Automatic Restart Function

After the cause of the fault has been removed, the following faults can be reset:

- With the automatic restart function (Atr parameter in the FLT- menu, see the *ATV31 Programming Manual*),
- Via a logic input (rSF parameter in the FLT- menu, see the *ATV31 Programming Manual*),
- By cycling power to the drive controller.

Faults Which Can be Reset With Automatic Restart

Fault	Probable Cause	Remedy
LD F Serial link failure CANopen	Loss of communication between drive controller and communication device or remote keypad.	<ul style="list-style-type: none"> • Check the communication bus. • Refer to the product-specific documentation.
EP F External fault	User defined	User defined
LF F Loss of 4-20 mA follower	Loss of the 4-20 mA reference on input AI3	Check the connection on input AI3.
DB F Overvoltage during deceleration	<ul style="list-style-type: none"> • Braking too rapidly • Overhauling load 	<ul style="list-style-type: none"> • Increase the deceleration time. • Install a braking resistor if necessary. • Activate the brA function if it is compatible with the application. Refer to the <i>ATV31 Programming Manual</i>.
DHF Drive overload	<ul style="list-style-type: none"> • Drive controller or ambient temperature are too high. • Continuous motor current load is too high. 	Check the motor load, the drive controller ventilation, and the environment. Wait for the drive controller to cool before restarting.
DL F Motor overload	<ul style="list-style-type: none"> • Thermal trip due to prolonged motor overload • Motor power rating too low for the application 	Check the Ith setting (motor thermal protection, page 32), check the motor load. Allow the motor to cool before restarting.

Faults Which Can be Reset With Automatic Restart (Continued)

Fault	Probable Cause	Remedy
DP F Motor phase failure	<ul style="list-style-type: none"> • Loss of phase at drive controller output • Downstream contactor open • Motor not connected • Instability in the motor current • Drive controller oversized for motor 	<ul style="list-style-type: none"> • Check the connections from the drive controller to the motor. • If a downstream contactor is being used, set OPL to OAC. Refer to the <i>ATV31 Programming Manual</i>, FLT- menu. • Test the drive controller on a low power motor or without a motor: set OPL to nO. Refer to the <i>ATV31 Programming Manual</i>, FLT- menu. • Check and optimize the UFr (page 32), UnS (page 35), and nCr (page 35) parameters and perform auto-tuning (page 36).
DS F Overvoltage during steady state operation or during acceleration	<ul style="list-style-type: none"> • Line voltage too high • Line supply transients 	<ul style="list-style-type: none"> • Check the line voltage. Compare with the drive controller nameplate rating. • Reset the drive controller.
PH F Input phase failure	<ul style="list-style-type: none"> • Input phase loss, blown fuse • 3-phase drive controller used on a single phase line supply • Input phase imbalance • Transient phase fault <p><i>Note: This protection only operates with the drive controller running under load.</i></p>	<ul style="list-style-type: none"> • Check the connections and the fuses. • Disable the fault by setting IPL to nO. Refer to the <i>ATV31 Programming Manual</i>. • Verify that the input power is correct. • Supply 3-phase power if needed.
SL F Serial link failure Modbus	Loss of connection between drive controller and communication device or remote keypad.	<ul style="list-style-type: none"> • Check the communication connection. • Refer to the product-specific documentation.

LV20

LV20-TS PANEL FOR KES TOUCHSCREEN FACTORY WIRING

LV20 TRUFLOW TRANSDUCER SCHEMATIC

KES1 CAT5 CONNECTION
 (AUX1)IN1 = prefilter +ve
 (AUX1)IN2 = bag +ve
 (AUX1)IN3 = box +ve
 (AUX2)IN0 = T4 mxflow +ve
 (AUX2)IN0 = T4 mxflow -ve

KES1 CAT5 CONNECTION
 +24VDC
 Common -ve
 5 = high temp return
 (AUX2)OUT1 = PXR INPUT+ve
 (AUX2)OUT1 = PXR INPUT-ve
 (AUX1)IN0 = pxr output +ve
 (AUX1)IN0 = pxr output -ve

1ST CAT5 LV1
 blue
 blue+white
 orange
 white orange
 brown

2ND CAT5 LV2
 green
 white green
 blue
 white blue
 orange
 white orange
 brown

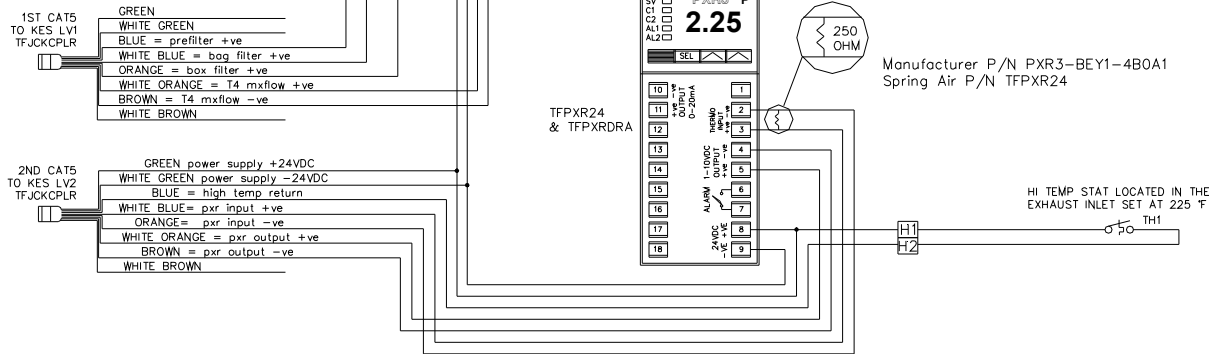

Factory Wiring LV20
Figure 45

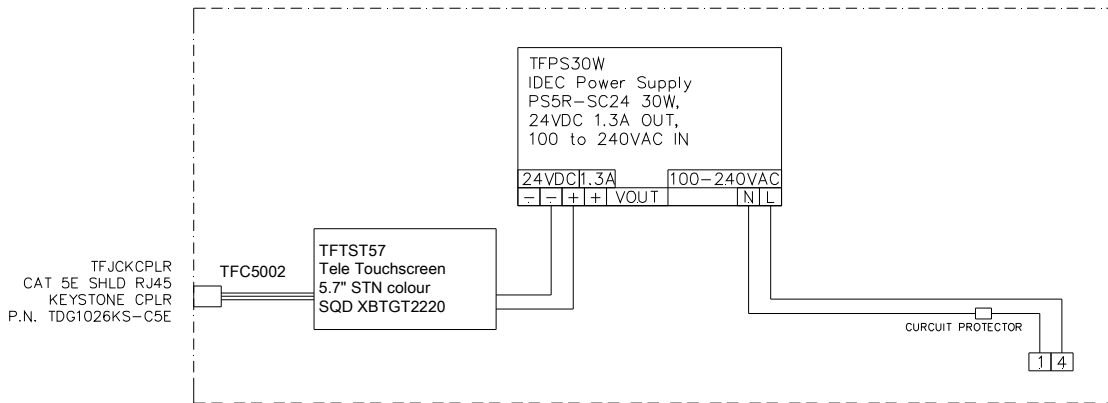

RPD-KD-TS Remote
Figure 46

O. Odor Spray Compressor Maintenance

Do not, at any time lubricate any of the parts with oil, grease, or petroleum products nor clean with acids, caustics or chlorinated solvents. Be very careful to keep the diaphragm from contacting any petroleum product or hydrocarbons. It can affect the service life of the pump.

To clean or replace the filters and/or rubber gasket, remove the five screws in the top of the unit. The filters and gaskets are located beneath this top plate. Remove the filters and wash then in a solvent and/or blow off with air and replace. The gasket may be cleaned with water. Replace the filters in proper position and replace the gasket. Note that the gasket and top plate will fit in one position only.

To replace the diaphragm, remove the socket cap screws from the head of the pump. The diaphragm is held in place by two Philip head screws. Remove screws, retainer plate, and diaphragm. The diaphragm will fit in any position on the connecting rod. Replace the plate and the two Phillips head screws. Torque to 30 inch-pounds on DOA and DAA.

Caution: Do not raise any burrs or nicks on the heads of these screws. These burrs could cause damage to the inlet valve. For replacing the inlet and outlet valve, remove the slotted machine screw that holds each valve in place. The stainless steel inlet and outlet valves are interchangeable. Clean them with water. When replacing the outlet valve, place the new valve in location and note there is a retaining bar near the machine screw hole. This retaining bar holds the valve in position. When replacing the inlet valve, note that the valve holder is marked with an X in one corner. This X should be in the lower right hand corner toward the inlet of the air chamber. Replace the head and tighten the socket head screws to 90-100 inch-pounds or torque on DOA and DAA.

WARNING -
The motor is thermally protected and can automatically restart when the protector resets. ALWAYS disconnect KES fan power source before servicing.

Do not attempt to replace the connecting rod or motor bearings. If after cleaning the unit and/or installing a new service kit, the unit still does not operate properly, contact your representative, the factory, or return the pump to one of our authorized Service Centers.

IF YOUR PUMP IS EQUIPPED WITH PLASTIC PLUGS IN THE EXHAUST AND/OR INTAKE POTS, REMOVE BEFORE STARTING THE UNIT

Wiring Information

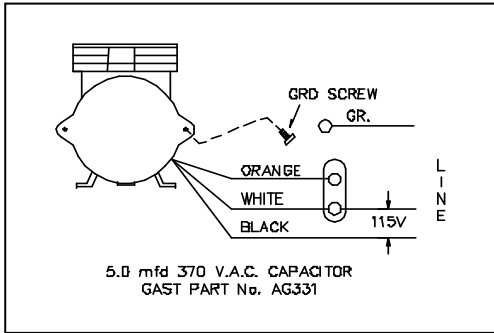
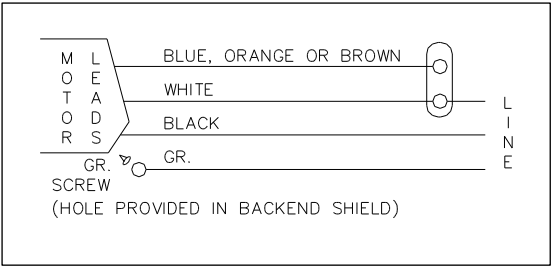

For any permanent split capacitor motor, which has four (4) leads is as follows:

Brown leads to capacitor. Black leads to Power Source.

For any permanent split capacitor for DOA & DAA motor, which has three (3) leads is as follows:

IMPORTANT NOTICE:

DO NOT AT ANY TIME ATTEMPT TO REMOVE THE CONNECTING ROD OR COMPLETELY DISASSEMBLE THE PUMP. IF IT DOES NOT GIVE YOU THE PROPER SERVICE EVEN AFTER INSTALLING A NEW SERVICE KIT, PLEASE RETURN IT TO ONE OF THE AUTHORIZED SERVICE CENTERS



MATERIAL SAFETY DATA SHEET

Product: SOLUTION C-10

Ecolo-Bio
 1010, Boul. Lionel-Boulet
 Varannes, Québec, J3X 1P7
 EMERGENCY PHONE: 450-652-5878 FAX: 450-652-3582
 (613) 996-6666 (CANUTEC)

1- PRODUCT INFORMATION:

Product Manufacturer: Ecolo-Bio
 Product Identifier: C-10
 Product Use: All purpose liquid detergent.

2- HAZARDOUS INGREDIENTS:

THRESHOLD LIMIT
 MATERIAL or COMPOUND: C.A.S. No.: PERCENT: VALUE (TLV) LD50/LC50
 W/W PPM: mg/m3

Not applicable.
 NAP: Not Applicable, NAV: Not Available

3- PHYSICAL DATA:

Physical State: Liquid.
 Appearance and Odor: Clear blue liquid, light perfumed.
 Odor Threshold: Not available.
 Specific Gravity: 1.065
 Vapor Pressure: Not available.
 Vapor Density: Not available.
 Evaporation Rate: < 1 (Butyl acetate=1)
 Boiling Point: > 100oC
 Freezing Point: < 0oC
 pH: 1% solution : 10.5-10.9
 Coefficient of Water/Oil Distribution: Not available.
 Percent Volatile: > 75%
 Solubility in Water: 100%

4- FIRE AND EXPLOSION HAZARD DATA

Conditions of Flammability: None known.
 Extinguishing Media: Not applicable.
 Flash Point and Method: Not applicable.
 Flammable Limits - UEL: Not applicable.
 Flammable Limits - LEL: Not applicable.
 Auto-Ignition Temperature: Not applicable.
 Hazardous Combustion Product: Oxide of carbon.
 Sensitivity to Mechanical Impact / Static Discharge: Not applicable.
 Unusual Fire And Explosion Hazards: None known.

5- REACTIVITY DATA

Stability, If Not, Under Which Condition: Stable.
 Incompatibility - Materials to Avoid: Acid.
 Hazardous Polymerization: Will not occur.
 Corrosion: None known.
 Hazardous Decomposition Products: Not available.

MATERIAL SAFETY DATA SHEET

Product: SOLUTION C-10

6- PREVENTIVE MEASURES

Environmental Data: Not available.
Handling: Practice good industrial hygiene when handling this product.
Personal Protective Equipment:
Eye Protection: Safety glasses.
Hand Protection: Glove, if necessary.
Respiratory Protective Equipment: Not normally necessary.
Other Protective Equipment: Not normally necessary.
Recommended Disposal: Disposal should be in accordance with applicable regulations.
Spill Response: Absorb with a commercial absorbent, Wash the area with water.
Storage Requirements: Avoid freezing.
Ventilation Requirements: Mechanical (general).

7- TOXICOLOGICAL PROPERTIES

ROUTE OF ENTRY: Eyes and skin contact. Inhalation.

7.1 - EFFECTS OF ACUTE EXPOSURE:

Eye Contact: Possibility of a light irritation.
Skin Contact: Possibility of a light irritation.
Inhalation: Possibility of a light headache.
Ingestion: Gastric discomfort, Diarrhea.
OECD 404..... Test conducted on product of same nature had shown a mean of less than one for erythematic and zero for edema.

7.2 - EFFECTS OF CHRONIC EXPOSURE:

Carcinogenicity: Not applicable.
Reproductive Toxicity: Not applicable.
Teratogenicity: Not applicable.
Mutagenicity: Not applicable.
Synergistic Product: Not available.
Sensitization: Not available.

8- SUGGESTED FIRST AID

Eye Contact: Rinse with plenty of water during at least 15 minutes.
Skin Contact: Wash with plenty of water.
Inhalation: Remove victim to fresh air.
If Swallowed: Drink plenty of water.
Other First Aid: Contact a physician.

9- ADDITIONAL INFORMATION

TDG Classification: Not-regulated.
WHMIS Classification: Not-regulated.

10- PREPARATION INFORMATION

Preparation: EcoLo-Bio TEL: 450-652-5878 FAX: 450-652-3582
Code. : 022804
Date of Preparation: revised January 6th 2010
The opinions expressed herein are those of qualified experts within ECOLO-BIO. We believe that the information contained herein is current as of the date of this Material Safety Data Sheet. Since the use of this information and of these opinions and the conditions of use of the product are not within the control of ECOLO-BIO, it is the user's obligation to determine the conditions of safe use of the product.

MATERIAL SAFETY DATA SHEET

ENVIRONMENTAL ODOR CONTROL CORP.
191 ST. DAVID STREET, UNIT 7, LINDSAY, ONTARIO R9V 3K7

SECTION 1 - IDENTIFICATION

Issue Date: JANUARY 01/10 **Contact:** 1-705-328-3305
Emergency: 1-201-825-7595

PRODUCT NAME: SPRING FRESH

Chemical Identify: The specific chemical identities of the ingredients in this are considered by us to be trade secrets and are withheld in accordance with the provisions of 1910, 1200 of the code of federal regulations.

Product Use: Deodorizes garbage odors

WHMIS Classification: Class D-2B-CPR 63

TDG Classification: Not appl.

SECTION 2 - HAZARDOUS INGREDIENTS OF MATERIAL

Hazardous Rating: Health: 1 Fire: 1 Reactivity: 0

Health Hazards Including Signs

Symptoms of Overexposure: This mixture has not been tested as a whole. None of the ingredients are listed as carcinogens or potential carcinogens by OSHA

SECTION 3 - PHYSICAL DATA

Physical State:	Liquid	Solubility in Water:	Completely soluble
Color:	Yellow	Odor:	Floral mint, citrus
Flash Point:	Over 200 F	Boiling Point:	Aqueous solution
Specific Gravity:	1.025	Vapor Pressure:	Now known
Vapor Density (Air-1):	Not appl.	% Volatile:	>87%

SECTION 4 - FIRE AND SECTION EXPLOSION HAZARD DATA

Flash Point: Not known
Extinguishing Media: Carbon dioxide, foam, dry chemical
Special Fire Fighting Procedures: Self contained breathing apparatus and protective clothing should be worn

Unusual Fire & Explosion

Hazards: Closed containers may build up pressure at elevated temperatures. Cool with spray.

Flammable Limits: Not known

SECTION 5 - REACTIVITY DATA

Chemical Stability: Stable
Incompatibility: Avoid contact with strong acids, alkalis or oxidizing agents

Hazardous Decomposition Products: Carbon monoxide and unidentified organic compounds may be formed during combustion

Hazardous Polymerization Products: Will not occur

SECTION 6 - HEALTH AND HAZARD DATA

Inhalation:	May cause irritation to nose and throat If breathing is irregular, call a physician
Eyes:	Flush immediately with water for at 15 minutes
Skin Contact:	Wash affected area with soap and water. Remove contaminated clothing. If irritation persists, call a physician
Indigestion:	Do "NOT" induce vomiting. Drink water or milk to dilute. Call a physician.

SECTION 7 - PRECAUTIONS FOR SAFE HANDLING

Leak and Spill Procedure:	Flush with water or remove in any water proof container. Ventilate area.
Waste Disposal Methods:	Dispose of in approved land fill site
Handling and Storage	
Precautions:	Keep containers tightly closed and upright when when not in use

SECTION 8 - FIRST AID MEASURES

Eyes:	Use goggles or face shield if eye contact may occur
Clothing:	Wear chemically resistant gloves if handling large volumes of chemical
Respiratory:	None generally required. In poorly ventilated area wear NIOSH approved respirator
Ventilation:	Provide adequate ventilation. Use exhaust fan if necessary
Work Practices:	Normal personal hygiene practices should be followed when handling chemical

SECTION 9 - DISCLAIMER

The information in this MSDS was obtained from current and reliable sources. However, the data is provided without any warranty, expressed or implied, regarding its correctness or accuracy. Since the conditions of handling, storage and disposal of this product are beyond our control, it is the responsibility of the use both to determine safe conditions for use of this product and assume full responsibility for loss, injury and expense arising our of the products improper use. No warranty, expressed or inferred, regarding the product described in this MMSDS shall be created or inferred by any statement of this MSDS. Various government agencies may have specific regulations regarding transportation, handling, storage, use of disposal of this product which may not be covered in this MSDS. The use is responsible for full compliance.

R. Touchscreen Initial Set-up

Login as Administrator. If you do not have the Administrators password call Spring Air Systems Inc. head office Service Manager. **ONLY ADMINISTRATOR LOGIN WILL ALLOW YOU TO PERFORM THE STARTUP.**

- 1) Do not power on the fan(s) prior to the set up.
- 2) Only administrator can sign in and proceed with the initial set up or make any changes to the system.
- 3) If the system is being set up for the first time errors will appear on the screen. Do not attempt to address these errors. Proceed with the initial set up instructions.

Follow the instructions step-by-step in order to complete the initial set up. This set up will allow you to set up the system when it is being installed for the first time.

Pre-Start Checklist

- ___ 1. The circuit breaker is on and providing 120V/1/60.
- ___ 2. The commercial kitchen surface fire suppression system must be installed as per NFPA code and tagged.
- ___ 3. The commercial kitchen exhaust hood(s), exhaust fan(s) and supply fan(s) have been installed in accordance with all applicable national and local codes.
- ___ 4. All equipments have been installed as per engineering drawings.
- ___ 5. The interconnection wiring has been installed as per engineering drawings.
- ___ 6. The interconnection wiring and cables have been installed in accordance with all applicable National and Local Codes.

General Information

Spring Air Service Company	
Job Name	
File Number	
Date of startup **REQUIRED FOR WARRANTY PURPOSES	
Customer	
Location	

TECHNICIAN MUST FILL IN ALL SHADED AREAS

General

Item	Description	Y / N
1	Check if the exhaust ductwork from the KES-ISH filter box (or complete KES unit) to the kitchen exhaust hood is all welded per NFPA-96	
2	Check if clearance to top, sides, and ends of KES filter box is available: 18" to combustible or 6" to non-combustibles	



Filters



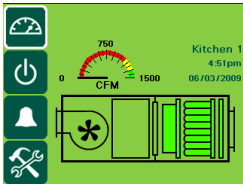

Type of Filter	Size	Qty Shipped	Qty on Site
3	Prefilter	12" x 24" x 2"	
4	Prefilter	24" x 24" x 2"	
5	Bag Filter	12" x 24" x 22"	
6	Bag Filter	24" x 24" x 22"	
7	Box Filter	12" x 24" x 12"	
8	Box Filter	24" x 24" x 12"	

Electrical

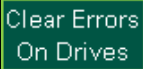

Item	Description	Y / N
9	Check all electrical connections. Tighten as necessary	
10	Check for power wiring from KESF control transformer to KES-ISH filter box LV10 panel, 120V1/60. (If KESF and KES-ISH are shipped in one piece than this wiring is done by factory)	
11	Check LV10 J-Box wiring to odor spray 4 & 17 (Optional: for odor spray units only)	
12	Check for power to remote Touchscreen panel RPD-KD11 from breaker panel, 120V1/60	
13	Check CAT5 LV1 cable from LV10 to LV20 with cable tester	
14	Check CAT5 LV2 cable from LV10 to LV20 with cable tester	
15	Check CAT5 VFD cable from LV10 to Mxflow drive on KESF fan section with cable tester.	
16	Check CAT5 TSC cable from LV10 remote Touchscreen panel RPD-KD11 with cable tester. (The RPD-KD11 will normally be located in the kitchen area)	
17	Check for other interlocks from the LV10 panel as required. Review the project drawings for the optional interlocks such as supply units, summer/winter, supply inlet damper, fire suptouchion, and shunt trips.	
18	Check for power to KESF fan disconnect switch from breaker panel, generally three phase.	
19	Measure voltage at KESF fan disconnect switch. The fan motor Voltage can be measured with a standard amp-probe	3/60/ V

Check fan rotation as follows:

20	Turn on the breaker to KESF fan unit.	
21	Turn on the main disconnect to the KESF	
22	Turn on the breaker to remote Touchscreen panel RPD-KD11.	
23	<p>At the Touchscreen panel. Wait for the panel to power on and the dashboard to appear.</p>  <p>Touch the power screen icon</p>  <p>Touch the manual operation icon.</p>  <p>Touch the KES on icon.</p> <p>Return the KESF fan section. Turn off the disconnect switch. Open the fan and drive access door as the KESF slows down. View the direct of the wheel rotation in regards to the markings on the housing.</p> <p>To correct fan rotation switch two of the high voltage wires on terminals V/T1, U/T2 or W/T3 on the drive or switch two wires at the motor. CAUTION: DISCONNECTING ALL POWER TO THE KESF UNIT BEFORE ADJUSTING ROTATION</p>	
24	Turn on the main disconnect to the KESF	

25	<p>Return to the Touchscreen panel.</p> <p>There will be a message because you have shut power off to the drive from the breaker panel. Touch the screen.</p>   Touch the Operation Status screen icon
	 On the alarm screen touch the Clear Errors On Drives icon. It is located in the top right corner of the screen.
	 Touch the Dashboard icon to return the dashboard.
26	Turn the KES unit again from the Power On screen as in item 23 above.

Quick Exhaust Volume Check before Measuring Exhaust at Hoods

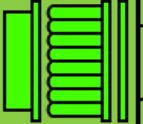
27	 Touch the Setup icon. From the Setup screen login with your password. If you do not have the Touchscreen password contact the factory immediately as it is required to continue.
	 Once you have the login is complete touch the Dashboard icon.
	 On the Dashboard touch anywhere on the three particulate filters to view the filter operation screen.

28	 <p>From the Filter operation screen view the actual static pressure across each filter.</p> <p>The static pressure across each filter is show in each filter box below the filter name. On the illustration on the left the pressure is 0 for each filter because the unit is not on. The static pressure on your screen should have values for each particulate filter.</p> <p>The actual static pressure for the Box filter should be between 0.50 and 0.75. If the reading does not fall within this range adjust the PXR SV. To increase the pressure reading, increase the PXR SV setting.</p> <p>To decrease the pressure reading, decrease the PXR SV setting. See page 16 and 17 for instruction to adjust the PXR settings.</p>
29	Measure the exhaust air volume at each hood. Complete the hood start up form.
30	Once the exhaust volume is measured adjust the PRX SV up to increase air volume and down to decrease air volume



PXR Settings with Clean Filters	
31	SV Setting on PXR: Operating Pressure on PXR screen VFD running Hz. Fan Motor Amp.

Setting Dashboard CFM Range

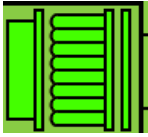
32



On the Dashboard touch anywhere on the three particulate filters to view the filter operation screen





Touch the number 3.0 on the Optimal Air Flow icon on the Filter Operation screen

Enter the SV Setting on the PXR as the Optimal Air Flow value. Enter the KES CFM in the CFM value Touch OK when complete

Pre filter Clogged Test

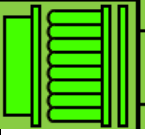
33



On the Dashboard touch anywhere on the three particulate filters to view the filter operation screen.

Touch the Prefilter Clogged set value. Enter a value lower than the actual pressure reading for the Prefilter.

34	 <p>After 30 seconds the message screen appears and the KES unit shuts off. Touch the screen anywhere</p> <p>Touch the override button on the top right of the screen.</p> <p>The unit shut start again and a four hour clock will start to count down.</p>	Yes	No
36	Return to the Filter operation screen and reset the prefilter clogged setting to 0.75".W.	Yes	No
37	Return to the Power screen and turn the unit on and off and on	Yes	No

Bag filter Clogged Test

38

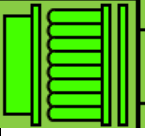



On the Dashboard touch anywhere on the three particulate filters to view the filter operation screen.

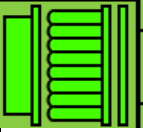

Touch the Bag filter Clogged set value. Enter a value lower than the actual pressure reading for the Bag filter.

39	 <p>After 30 seconds the message screen appears and the KES unit shuts off. Touch the screen anywhere</p> <p>Touch the override button on the top right of the screen.</p> <p>The unit shut start again and a four hour clock will start to count down.</p>	Yes	No
40	Return to the Filter operation screen and reset the Bag filter clogged setting to 1.25".W.	Yes	No
41	Return to the Power screen and turn the unit on and off and on	Yes	No

Box filter Clogged Test

42		<p>On the Dashboard touch anywhere on the three particulate filters to view the filter operation screen.</p> <p>Touch the Box filter Clogged set value. Enter a value lower than the actual pressure reading for the Prefilter.</p>		
43		<p>After 30 seconds the message screen appears and the KES unit shuts off. Touch the screen anywhere</p> <p>Touch the override button on the top right of the screen.</p> <p>The unit shut start again and a four hour clock will start to count down.</p>	Yes	No
44	Return to the Box Filter operation screen and reset the Box filter clogged setting to 1.5".W.		Yes	No
45	Return to the Power screen and turn the unit on and off and on		Yes	No

Bag filter out Test

46		<p>On the Dashboard touch anywhere on the three particulate filters to view the filter operation screen.</p> <p>Touch the Bag filter Out set value. Enter a value lower than the actual pressure reading for the Bag filter.</p>		
47		<p>After 30 seconds the message screen appears and the KES unit shuts off. Touch the screen anywhere.</p>	Yes	No
48	Return to the Filter operation screen and reset the Bag filter OUT setting to 0.05".W.		Yes	No
49	Go the alarm screen and clear the alarm.		Yes	No

IMPORTANT AMP CHECK AT HIGH HZ VALUE

50	Check operating motor amps at high HZ value.		
51	Increase the SV set point on the PXR until the VFD is running on the highest setting. 65 HZ		
52	Check the fan motor amperage. If the motor is operating over the motor FLA, reduce the high Hz setting by 2 Hz increments until correct FLA is reached. Adjust the high HZ value on the VFD. See manual for instructions to reduce high HZ value on drive.		
53	Reduce the low Hz setting by the same incremental amount that the high setting was reduced. For example if the high is reduced from 65 to 60 then the low must be reduced from 48 to 43 HZ.		
54	New VFD drive settings	HIGH	LOW

Actual Filter pressure readings

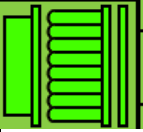
55		<p>On the Dashboard touch anywhere on the three particulate filters to view the filter operation screen.</p> <p>Enter the values in the chart below.</p>
----	---	--

56	Prefilter actual reading	
57	Prefilter Clogged Set Point	
58	Bag actual reading	
59	Bag Filter Clogged Set Point	
60	Bag Filter Out set point	
61	Box actual reading	
62	Box Filter Clogged Set Point	
63	Box Filter Out set point	

Hi Temperature Switch Test

64	Jumper terminals 1 & 16 in the LV10 Panel		
65	KES unit shuts off	Yes	No
66	 <p>Message signals on the Touchscreen Dashboard. Touch the screen anywhere. Go to the Operation Status screen and clear the message. The KES unit stays off.</p>	Yes	No
67	Remove the jumpers from 1 & 16 in the LV10 panel.		

Comments:

Technician signature _____ Print Name _____

S. CHANGING EXHAUST AIR VOLUME ON SITE

With the MXFLOW system changing the exhaust air volume on site is a simple and easy task. First complete the startup report attached in the back of this manual. Once the report has been completed and the system is operating satisfactory measure the actual exhaust air volume using the appropriate air flow measuring device.

The exhaust air volume can be adjusted approximately +/- 15% from the factory setting with the touch of a button.

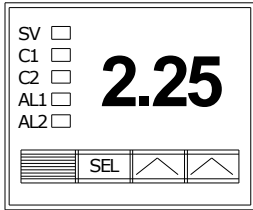

To adjust the exhaust volume, touch the SEL. The SV lamp is on. To increase the exhaust volume adjust the static pressure set point up with the ^ button. To decrease the exhaust volume, adjust the static pressure set point down with the v button. The rule of thumb is approximately 0.5 increase or decrease to change the exhaust volume by 5%. This is only a rule of thumb. After the adjustment the exhaust volume must be measured again. After three seconds the DMP will operate at the new SV setting.

SETTING DASHBOARD CFM RANGE

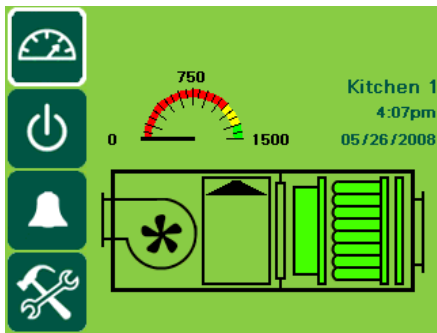

The CFM can not be set on the dashboard until the kitchen ventilation system has been balanced at the correct design CFM. After commissioning the system measure the exhaust CFM. If the exhaust CFM must be adjusted see the above section *CHANGING EXHAUST AIR VOLUME ON SITE*. Adjust the exhaust CFM as required.

After the exhaust CFM is set read the value on the PXR in the LV20 panel. This value is the actual (Optimal Air Flow) inlet static pressure of the KES-ISH filter unit at design CFM.

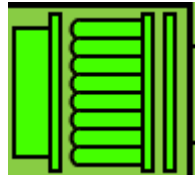

On the Dashboard touch any part of the three particulate filters. The filter setup screen will appear. Both the Optimal Air Flow and CFM must be set for this kitchen exhaust application

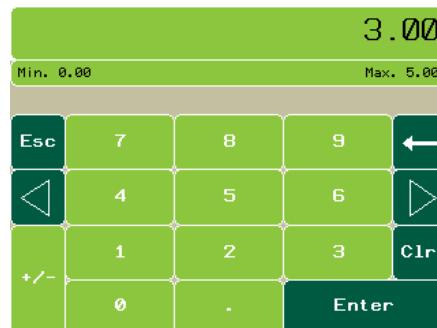

Touch the 3.00 beside "Optimal Air Flow".

Using the pop-up keypad enter the actual inlet static pressure reading from the LV20 PXR above. Touch Enter to return to previous screen.



Touch the 1500 beside “CFM”

Using the pop-up keypad enter the CFM of the application. Touch Enter to return to previous screen

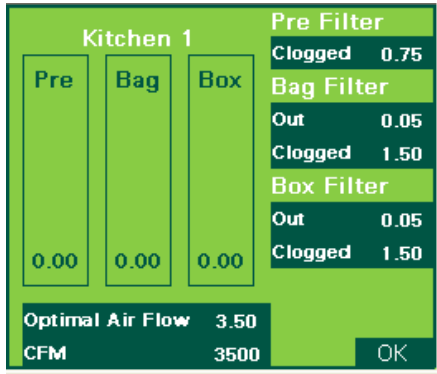

Touch OK to return to the Dashboard.

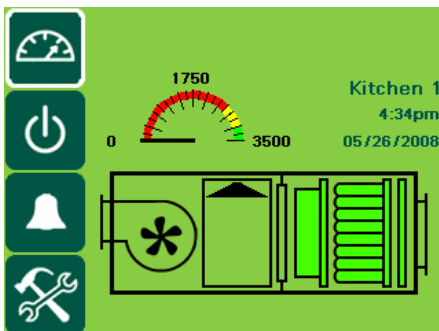

The Dashboard Speedometer is now scaled the CFM of the kitchen ventilation system.

T. Field Connecting the KES-ISH Filter Box and KESF Fan Box

1. The complete unit is shipped in two pieces as outlined on the drawings.
2. Uncrate the filter and fan box and place on a level surface. Align the KES-ISH filter box discharge (this is the end with the fire damper in the duct collar) so that it is facing the KESF fan unit inlet.
3. There is a neoprene gasket attached to the KES-ISH filter box inside standing flange. Check to ensure that it is still in place on the flange inside the boltholes pattern. If parts of the gasket have been removed reseal them with silicone.
4. Remove the nuts, bolts and lock washers from a box in the KESF fan section.
5. Slide the KESF inlet fan section into the KES-ISH filter box.
6. Align the bolt holes on the top and lower side exterior standing flange of the KES_ISH filter unit and KESF fan unit. Insert the four bolts. One in each of the top corners and one in each of the bottom sides of the KES-ISH filter and KESF fan section. Place lock washers and nuts on the end of the bolts and tighten each corner. Check periodically that the other bolt-holes remain aligned.
7. Enter the unit through the KES_ISH filter section box filter access door and insert the bolts and nuts into the standing flange at the bottom of the KES_ISH filter and KESF fan unit. Tighten these nuts and bolts uniformly.
8. Insert bolts into each side of the base flanges where the exterior bases of KES-ISH filter and KES fan unit meet. The base at the outside lifting point of the two pieces.
9. Continue to insert the bolts, lock washers, and nuts in the remaining boltholes connecting the KES-ISH filter and KESF fan boxes. It is best to start in the middle of the top and ends and work back towards the corners.
10. Reconnect the electrical connection from KES-ISH LV10 panel to the KESF motor starter. The original connection was made in the factory and disconnected for shipment.

U. Hanging the KES-ISH Filter and KESF Filter Box

1. Complete the file connecting of the KES-ISH filter box and KESF fan section.
2. Once the pieces are together forming one unit the complete assembly can be suspended from the lifting points indicated on the dimensional drawings.
3. The total weight of the assembly is the weight of the KES-ISH unit plus the weight of the KESF fan unit. The weight distribution is outlined below as a percentage of the weight of each pieces.
4. The unit is suspended on six (6) hanging threaded rods through the holes in the web of the lifting flanges. Secure a bolt and lock washer to the end of each threaded rod under the unit flanges. Size the rods to hold the weight calculated for each rod below.

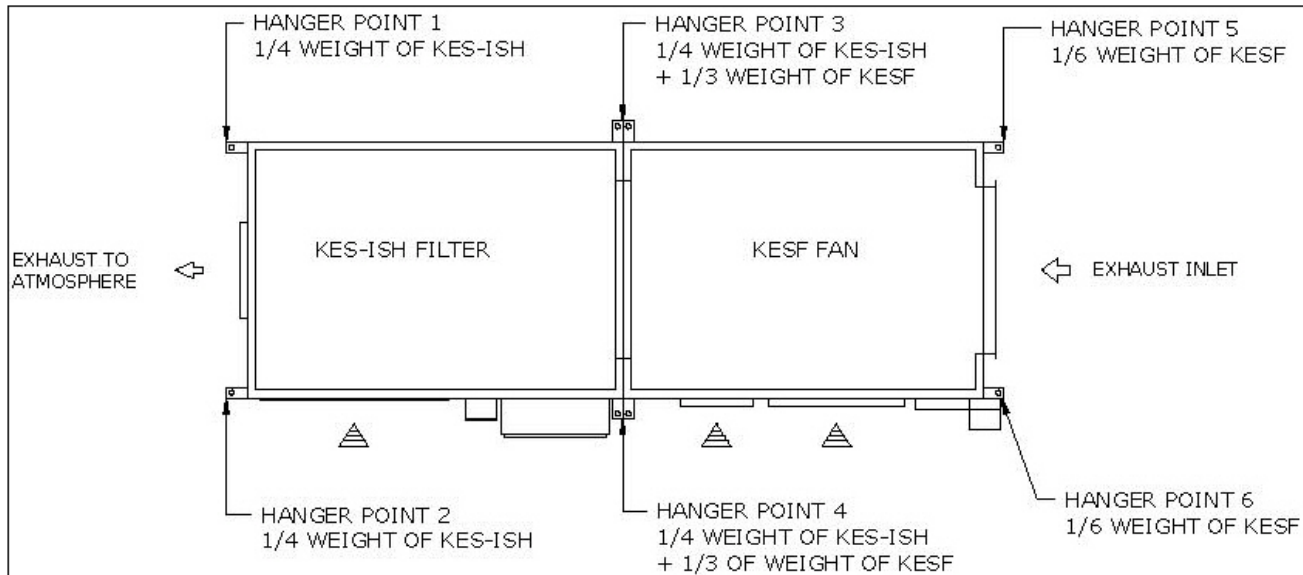

V. KES UNIT WEIGHT CHART (lbs)

KES Model Number	KES-ISH Filter Box	KESF Fan Unit DWDI	KESF Fan unit SWSI	KESV Vertical unit	Odor Pellet Section	Odor Spray Section
10	250	630	550	950	200	100
20	300	630	600	1050	300	100
30	350	710	700	1100	450	110
40	450	710	800	1300	500	110
50	550	950	1000	1650	550	150
50F	550	n/a	n/a	n/a	550	150
60	600	950	1100	1750	600	150
60F	650	n/a	n/a	n/a	600	150
80	700	1300	1350	2100	900	170
100	850	1600	1500	2550	1050	190
120	950	1700	1950	n/a	1250	200
140	1050	1850	2050	n/a	1450	220
160	1150	2250	2300	n/a	1600	250
180	1200	2300	2550	n/a	1850	250
200	1250	2450	2550	n/a	1950	275
240	1400	2750	2650	n/a	2400	300
280	1500	3150	3450	n/a	2600	350
320	1650	3700	4050	n/a	3100	400
360	1800	4350	4350	n/a	3300	465
400	1950	5000	4850	n/a	3800	550

Chart No.11

Notes:

2.KES Filter box discharge outlet duct dimensions are sized to suit the KES fan section inlet dimensions.

3.For outdoor units add 250 lbs. to the weight of the KESF and KES-ISH.

4.The KESF fan units with DWDI fans and internal or external isolation are available with exhaust discharge positions: UB up blast, DB down blast and TB straight through discharge.

The KESF fan units with SWSI fans and internal or external isolation are available with exhaust discharge positions: RB right discharge, LB left discharge, UB up blast and DB down blast. Right and left discharge based on looking into fan inlet. Access doors can be RS right side or LS left side based on looking into inlet of unit.

W. Touchscreen Troubleshooting Sheet

Full Message	What to do	Cause
Comm Port 2 VFD Comm/CAT5 cable fault	Acknowledge alarm on Touchscreen panel (clear error on drive).	If fans were still operating when this error displayed it was caused by a communication timeout error. This does not affect Touchscreen operation and is related to site conditions.
Comm Port 2 Error Drive X: Modbus communication	Check CAT5 wiring to Drive X.	Modbus to communication has failed.
Comm Port 2 remains with DriveX Communication Fault	PHANTOM DRIVE Access secondary toolbox. Check each drive by touching the Kitchen Icon to confirm that all drives are connected to each kitchen. If extra drive(s) are connected go to setup and delete drive.	The Touchscreen can not communicate with a drive that does not exist or is not connected.
cont'd.	NO DRIVES ARE OPERATING Access secondary toolbox. Check drive by touching the Kitchen Icon. If all drives have Hz reading, check continuity of the Cat5 cable from the Touchscreen to the 1st drive with a CAT5 TESTER. Once CAT5 is fixed, touch Clear Error on Drive on Touchscreen.	1 st CAT5 cable is not pinned out properly or has been damaged. Check if the drives are reading "SLF". In this case, cycle the power to drives.
	ONLY ONE DRIVE IS NOT OPERATING Access secondary toolbox. Check each drive by touching the Kitchen Icon to confirm that all drives are connected to each kitchen. If a drive is not connected go to setup and add the drive.	The Touchscreen can not communicate with a drive that has not been added to the Touchscreen panel through the setup. If the non-operating drive is a supply drive, check inputs to D & L on the terminal block in TF panel.
	ONLY ONE DRIVE IS NOT OPERATING Access secondary toolbox. Check drive by touching the Kitchen Icon. Look for drive with zero Hz reading and check continuity of the Cat5 cables with a CAT5 TESTER to that drive. Once CAT5 is fixed, touch Clear Error on Drive on Touchscreen.	A CAT5 cable is not pinned out properly or has been damaged.
	ONLY ONE DRIVE IS NOT OPERATING From the drive manually re-enter the drive program using instruction in the Spring Air Maintenance Manual Appendix.	Drive program may have been disrupted due to dirty or irregular voltage to drive.
	If the drive is still not operating go to the drive and write down the error code that appears on the drive. Cycle the power to the drive to reset the drive. This will only be successful if the drive error has been cleared. Call factory and advise the drive error code.	See "D" errors for further instructions on resetting drive errors and causes.
	If the drive is still not operating, go to the drive and open front cover with flat headed screw driver. Remove the green wire from LI5. If the drive LED displays SLF you must cycle power to drive. The drive will operate at high for an unlimited amount of time. Return to Touchscreen panel and acknowledge message.	Drive may have been damaged, call Spring Air Systems.
	No reply from PLC within Timeout period. (ModbusEquipment02)	Touch the X on the right side of the black message on the bottom of the screen to clear the error.
Plc returned error code. (ModbusEquipment1) appears after clearing error B1	Triangles show, but NO MESSAGE will appear on error list or screen. You may not be able to access any other screen. Check the cable from the PLC to the HMI. Replace if damaged. On KES units, confirm power is turned on to KES unit.	The cable from the PLC to the screen has become unplugged or is damaged.
No reply from PLC within Timeout period.	Check and repair cable to building LON or BACnet.	ComPort1 communication problem with the LON or BACnet.
DriveX: Line supply overvoltage fault/ Comm Port 2 Error	Check power supply to the drive to correct the fault. Cycle power to the VFD. Acknowledge message on Touchscreen (clear error on drive).	The voltage to drive indicated was too high. The Comm Port error is caused because the Touchscreen cannot communicate with the Drive.
DriveX: Line undervoltage fault / Comm Port 2 Error	Check power supply to the drive to correct the fault. Acknowledge message on Touchscreen (clear error on drive).	There is no voltage to the Drive or inconsistent power. The Comm Port error is caused because the Touchscreen cannot communicate with the Drive.

DriveX: motor phase loss fault 1 or 3 phase	Check if disconnect switch has been opened between drive and motor. Check for phase loss in motor. Acknowledge message on Touchscreen (clear error on drive).	The connection between the drive and motor has been lost. Either one or all three phases have been lost.
DriveX: motor overload/over-speed	Check motor overload setting and RPM. Cycle power to the VFD. Acknowledge message on Touchscreen (clear error on drive).	Motor overload setting is incorrect, the fan RPM is set too high, or there was a power surge to the fan.
DriveX: Exhaust over-current	Check for a mechanical blockage at fan; check for continuity of power from the VFD to motor. Cycle power to the VFD. Acknowledge message on Touchscreen (clear error on drive).	There is a mechanical blockage (e.g. discharge damper closed, something blocking the duct), a power surge, the drive is insufficient size for the motor, or the power between the VFD and motor has been disconnected/lost.
DriveX: Motor Overcurrent	Check FLA on motor and FLA on drive setup. Check wiring between drive and motor. Cycle power to the VFD. Acknowledge message on Touchscreen (clear error on drive).	Motor is drawing more current than FLA.
DriveX: Impending Short Circuit	Check fan for dead short, check acceleration speed. Acknowledge message on Touchscreen (clear error on drive).	Possible dead short at fan motor connected to drive soon, acceleration is too rapid.
DriveX: Motor short circuit	Correct short circuit at fan. Cycle power to the VFD. Acknowledge message on Touchscreen (clear error on drive).	Dead short at fan motor connected to drive.
DriveX: Drive over-heating	Turn off fan. Determine cause of high heat at drive. Correct cause of high heat. Turn on fan. Acknowledge message on Touchscreen (clear error on drive).	The drive is too hot. Possible failure of internal cooling fan in drive. Area where drive is installed is too hot.
DriveX: Internal Fault	Remove sources of electromagnetic interference. Cycle power to the VFD. Acknowledge message on Touchscreen (clear error on drive). If fault remains, call Spring Air Head Office.	Drive is receiving electromagnetic interference or has failed.
DriveX: Brake control fault	Check drive and motor connections. Check motor windings. Cycle power to the VFD. Acknowledge message on Touchscreen (clear error on drive). If fault remains, call Spring Air Head Office.	Brake release current was not reached, there is possibly a problem at the fan.
DriveX: Drive voltage disabled	Check input voltage at drive. Acknowledge message on Touchscreen (clear error on drive).	There is no input voltage to the drive.
DriveX: Line phase loss fault	Check power to drive. Cycle power to the VFD. Acknowledge message on Touchscreen (clear error on drive).	There is a phase loss at the drive.
KitchenX: Thermal Start	Touchscreen will automatically turn on exhaust fan for four hours. Acknowledge message. Turn on fan using TruFlow panel.	Cooking equipment was started prior to turning on the exhaust fans, PXR setting is too low.
KitchenX: Surface Fire	After clean up and reset of fire suppression system, touch "reset" on pop-up message.	The surface fire suppression has been activated.
J-Couple X Cable trouble	The Truflow has sent drives to high speed. Check all j-couple wiring and end of line resistors. Check PXR alarm setting is adequate for average operating temperatures of kitchen (refer to maintenance manual to adjust).	If j-couple cable is unplugged, PXR will show UUUU. If PXR alarm setting needs to be adjusted, PXR will show a number and LED light on at AL 1.
Hi Temp KES (X)!	Check filter status and replace if necessary. Check fire damper at KES. Check for mechanical blockage at discharge. Acknowledge message and turn on KES unit.	A high temperature has been reached in the KES unit.
No Error	Touchscreen will not respond when touched.	Clean screen with damp cloth.
KES(X) : Low Detergent!	Refill odour spray. Acknowledge message and turn on KES unit.	The odour spray for the KES unit is low and needs to be replaced.
CO2 threshold exceeded activation	Check CO2 levels in the kitchen. Acknowledge message on Touchscreen.	CO2 levels in the kitchen have exceeded "normal".
LV1 or LV3 cable fault	Check connections of LV1 or LV3 cables. Confirm continuity. Replace CAT5 cable if required. Acknowledge message on Touchscreen.	CAT5 cable is not plugged in, is not pinned out properly or has been damaged.

LV2 or LV4 cable fault	Check connections of LV2 or LV4 cables. Confirm continuity. Replace CAT5 cable if required. Acknowledge message on Touchscreen.	CAT5 cable is not plugged in, is not pinned out properly or has been damaged.
KESX: Pre-filter clogged	Touch OVERRIDE until filter can be replaced. KES unit will run for 4 hours. Replace filter.	Pre-filter is clogged and must be replaced.
KESX: bag-filter clogged	Touch OVERRIDE until filter can be replaced. KES unit will run for 4 hours. Replace filter.	Bag-filter is clogged and must be replaced.
KESX: box-filter clogged	Touch OVERRIDE until filter can be replaced. KES unit will run for 4 hours. Replace filter.	Box-filter is clogged and must be replaced.
KESX: bag-filter out	Replace the filter. KES unit will not run until filter is replaced.	Bag-filter has been removed or is clogged past use.
KESX: box-filter out	Replace the filter. KES unit will not run until filter is replaced.	Box-filter has been removed or is clogged past use.
KESX: Pre-filter transmitter fault	Check the secondary set up screen and read the MA value for the Prefilter signal to confirm. If value is 4 or less first check CAT5 pin out then replace Transducer.	The Transducer has failed or the CAT5 LV1 pin out is not correct.
KESX: Bag-filter transmitter fault	Check the secondary set up screen and read the MA value for the bag-filter signal to confirm. If value is 4 or less first check CAT5 pin out then replace Transducer.	The Transducer has failed or the CAT5 LV1 pin out is not correct.
KESX: Box-filter transmitter fault	Check the secondary set up screen and read the MA value for the box-filter signal to confirm. If value is 4 or less first check CAT5 pin out then replace Transducer.	The Transducer has failed or the CAT5 LV1 pin out is not correct.

Other Fine Products From



- RevLow Hoods
- DynaFlow Hoods
- TruFlow Energy Management Systems
- UL/ULC Listed Pollution Control Systems
- Dry Extractor Hoods
- Catridge Hoods
- Filter Hoods
- Water Wash Ventilators
- Surface Fire Suppression
- Commercial Kitchen Exhaust Fans
- Commercial Kitchen Supply Units
- Utility Distribution Systems

Phone: 866-874-4505, FAX: 905-338-0179

info@springairsystems.com
www.springairsystems.com