

REV-LOW HOOD

DD-B-F with MZ

Box Canopy Dry Extractor Makeup Air Exhaust Fire Damper

General Description

The *REV-LOW* hood is used on all single row cooking equipment lineups, wall mounted. The unit is ceiling hung with a recommended mounting height of 6'-6" (1981 mm) from the lower edge of the canopy to the floor. The ventilator is installed with the core extractor section over the cook's head. The hood is finished with a number 4 finish on exposed sides. The *REV-LOW* hood is available with fluorescent or incandescent lights wired to a J-box. The tempered makeup air is discharged down and/or horizontal, through perforated stainless steel panel located forward of the filter hood. The MZ plenums are shipped loose.

Efficiency

The *REV-LOW hood* is a revolutionary idea in commercial kitchen ventilator design. The *REV-LOW* allows the exhaust flow to be field adjusted from 90cfm/ft to 450cfm/ft over each appliance without affecting the overall efficiency of the ventilator. Your kitchen will exhaust the lowest minimum required anywhere to ventilate the appliances located under the hood. After your kitchen is complete, appliances can be Relocated, Added, or Removed from under the hood! It's a simple adjustment to fine-tune your ventilator to provide excellent smoke capture with maximum grease extraction.

Exhaust and Supply

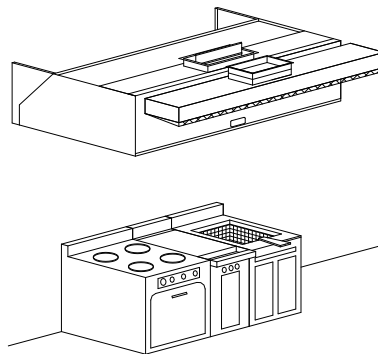

The *REV-LOW hood* exhaust calculations are outlined in the *REV-LOW Engineering Manual*. Heated fresh air is discharged out the front of the hood canopy for "MP". The complete kitchen ventilation system must be balanced; such that a minimum of 80% continuous heated makeup air is provided through dedicated makeup air systems or the kitchen A/C units. It is good engineering practice to provide this heated fresh air into the kitchen space. The heated fresh air should not exceed 90 percent of the total exhaust volume.

Model DD-B-F with MZ

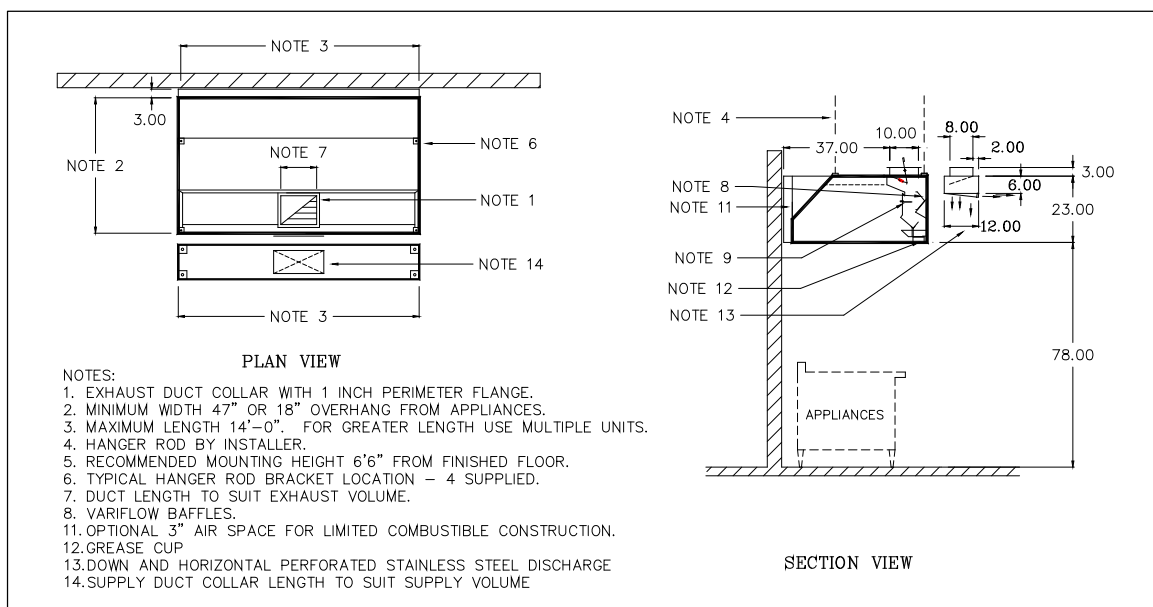

Exhaust Duct Sizes

Exhaust Volume		Exhaust Duct Collar Size	
CFM	l/s	W x L in x in	W x L mm x mm
450	212	10 x 4	254 x 102
500	236	10 x 4.5	254 x 114
625	295	10 x 6.0	254 x 152
750	354	10 x 7.0	254 x 178
875	413	10 x 8.0	254 x 203
1000	472	10 x 9.5	254 x 241
1125	531	10 x 10.5	254 x 267
1250	590	10 x 12.0	254 x 305
1375	649	10 x 13.0	254 x 330
1500	708	10 x 14.0	254 x 356
1625	767	10 x 15.5	254 x 394
1750	826	10 x 16.5	254 x 419
1875	885	10 x 18.0	254 x 457
2000	944	10 x 19.0	254 x 483
2125	1003	10 x 20.	254 x 508
2250	1062	10 x 21.5	254 x 546
2375	1121	10 x 22.5	254 x 572
2500	1180	10 x 24.0	254 x 610
2625	1239	10 x 25.0	254 x 635
2750	1298	10 x 26.0	254 x 660
2875	1357	10 x 27.5	254 x 699
3000	1416	10 x 28.5	254 x 724

Supply duct Sizes

Supply Volume		Supply Duct Collar Size	
CFM	l/s	W x L 8 in x	W x L 203mm x
350	165	10	254
400	189	10	254
450	212	10	254
500	236	10	254
550	260	10	254
600	283	10	254
650	307	14	356
700	330	14	356
750	354	14	356
800	378	14	356
850	401	16	406
900	425	16	406
950	448	16	406
1000	472	18	457
1050	496	18	457
1100	519	24	610
1150	543	24	610
1250	590	24	610
1300	613	24	610
1350	637	24	610
1400	661	24	610
1450	684	28	711

- 1.If exact exhaust volume is not indicated use duct size closest to required exhaust.
- 2.Model B-F water wash hoods and dry extractors have 1.5" W.C. (0.38kPa) for exhaust flow rates from 90 to 450 CFM/ft (140 to 700 l/s/m)
- 3.Refer to the REV-LOW Engineering Manual for detailed exhaust air volume calculations.
- 4.All hoods 8'0" (2438mm) and over must use two supply duct collars.

Spring Air Systems Model No. DD-B-F with MZ Hood Specification

The REV-LOW hood dry extractor shall be a Spring Air Systems model no. DD-B-F with MZ, box canopy, high efficiency, hood, with "MZ" down and horizontal discharge make up air plenum, UL/ULC listed, and built in accordance with the NFPA-96.

The unit casing shall be a minimum 18 GA. stainless steel on all exposed surfaces. The ventilator shall have a full-length inlet slot, a centrifugal vortex chamber, a vortex and a VARIFLOW baffle. The vortex chamber shall provide a full 270-degree centrifugal spin around the vortex baffle. The VARIFLOW baffles are field adjustable without special tools to provide the minimum exhaust volume.

Both chambers, the VARIFLOW baffles, the fire damper, and fusible link, shall be fully accessible through removable front grease inserts. The grease inserts shall also be removable without special tools. The grease trough and cup shall be constructed of stainless steel. The exhaust fire damper shall be an arrangement "D", butterfly type, constructed of stainless steel with blade and edge seals. The fire damper shall be activated by a fusible link and dead weight arrangement.

The heated makeup air discharge plenum ships loose. The MZ discharges down and horizontal through stainless steel perforated panels located on the front of the hood. The make up air plenum shall be insulated with 1" (25mm) attenuating foam. The hood shall have _____ incandescent/fluorescent lights evenly spaced along the length of the hood.

Engineering Data

Item Number: _____
 Model Number: DDBF with MZ _____
 Number of Sections: _____
 Hood Length: _____
 Hood Width: _____
 Lights: _____
 Exhaust Volume: _____
 No. of Exhaust Duct Collars: _____
 Size of Exhaust Duct Collar: _____
 Exhaust Static Pressure: _____
 Supply Volume: _____
 Supply No. of Duct Collars: _____
 Supply Size of Duct Collar: _____
 Supply Static Pressure: _____

Ddbf with mz