

DYNAFLOW HOOD

FN-B-MB

Box Canopy Filter/Cartridge Type



Dynaflow
UL/ULC listed
for 87" mounting
height

General Description

The hood is NFPA-96 Type 1 listed for use with all temperature ranges on single row, wall mounted cooking equipment lineups. The unit is ceiling hung with a maximum mounting height of 87" (2209 mm) from the lower edge of the canopy to the floor. The box canopy can be tapered to 11" (279 mm) at the front. The hood is finished with a number 4 finish on exposed sides. The *Dynaflow* hood is available with fluorescent, incandescent, or recessed incandescent lights wired to a J-box.

Efficiency

The *Dynaflow* hood is equipped with UL/ULC listed baffle grease filters or cartridges. Five extraction methods are available with *Dynaflow*.

VE – Value Engineered – standard grease extraction efficiency Stainless steel baffles.

CA – Medium grease extraction efficiency cartridges with adjustable flow baffles.

HE – High grease extraction Efficiency Cascade baffles for Enviro applications and reducing grease discharge from buildings.

EC – Easy Clean Teflon, Lower grease extraction efficiency baffles for hot, heavy grease laden appliances.

Spark Arrestor – standard grease extraction efficiency, for solid fuel appliances.

Exhaust and Supply

The *Dynaflow* design provides the lowest minimum exhaust. The *Dynaflow* hood exhaust volume is based on the appliances below the hood. It's a simple adjustment to fine-tune your ventilator to provide excellent smoke capture with maximum grease extraction.

Heated and/or cooled fresh air ducting is connected to the supply duct collar(s) on the top, front of the hood. The fresh air enters the fire damper in each supply duct connection and

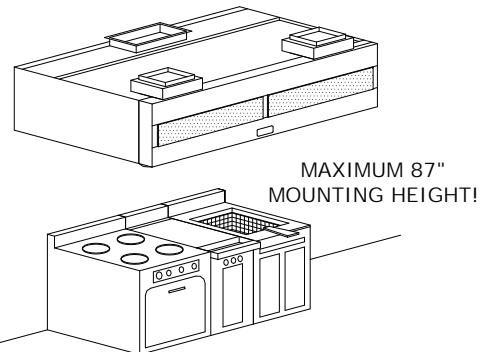

then discharges into the *Dynaflow* plenum. Within the plenum the fresh air is routed to three (3) regions within the boundaries of the appliances.

Three Appliance Boundary Regions

- Appliance Region:** Fresh air discharges down through a full length S/S perforated panel toward the kitchen appliances to reduce each appliance net exhaust required.
- Chef Region:** Fresh air discharges down through a full length S/S perforated panel towards the chef for a more comfortable work environment in front of the hood.
- Kitchen Ambient Region:** The horizontal fresh air discharges through a s/s perforated panel out the front of the hood into the kitchen to provide the exact amount of air to balance the kitchen and ensure optimum capture.

Dynaflow Operation

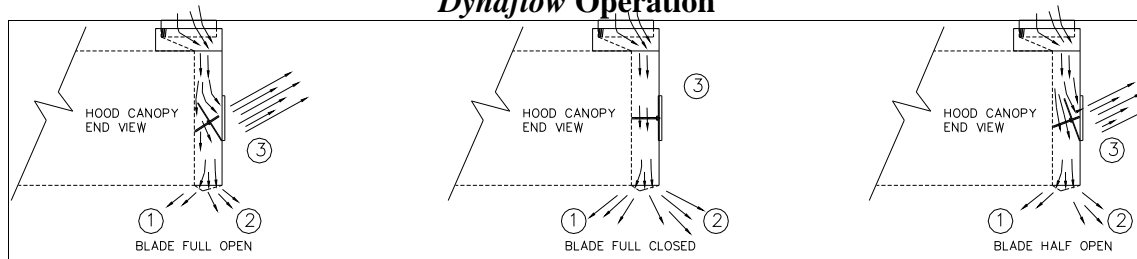

The internal blade (IB) is adjusted to direct fresh air between the Kitchen Ambient (3) Region, the Appliance (1) Region, and Chef(2) Region. The Comfort Tuning Blade (CTB) is adjusted to direct fresh air between the Appliance (1) Region and the Chef(2) Region. The complete kitchen ventilation system is always balanced. The IB and CTB are adjustable

every 24" (610mm) along the length of the *Dynaflow* hood to match the appliances underneath. *Dynaflow* operates with the lowest minimum exhaust. After your kitchen is complete, appliances can be Relocated, Added, or Removed from under the hood while maintaining maximum capture and chef comfort within the commercial kitchen.

Model FN-B-MB

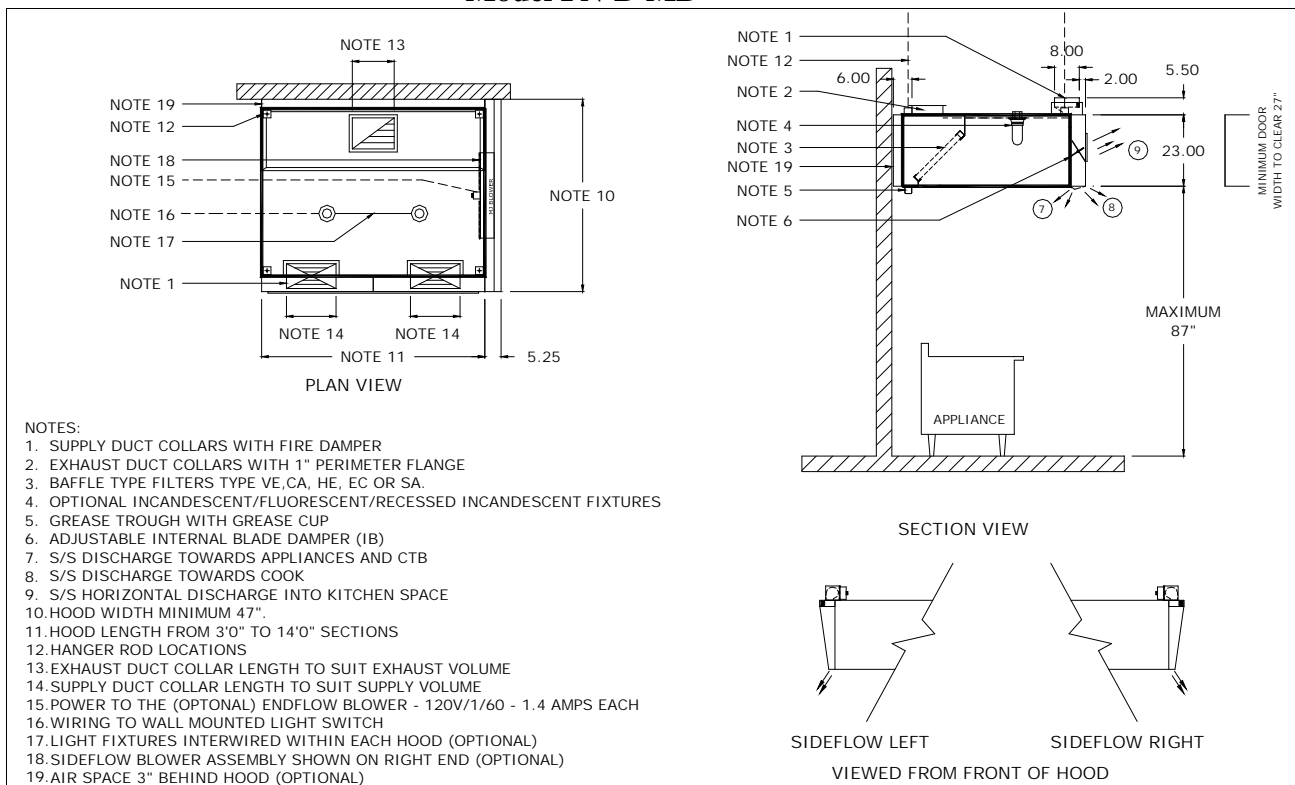

Spring Air Systems Model No. FN-B-MB Hood Specification

The Dynaflow hood, shall be a Spring Air Systems model no. FN-B-MB, box canopy, baffle extractor hood, with exhaust fire damper, "MB" Dynaflow air plenum, UL/ULC listed, NSF certified and built in accordance with the NFPA-96.

The baffle extractors shall be one of the following:

1. VE –Stainless steel baffles.
2. CA – Cartridges with adjustable flow baffles.
3. HE – High Efficiency Cascade
4. EC – Easy Clean Teflon baffles
5. SA – Spark Arrestor for sold fuel appliances.

The unit casing shall be a minimum 18 GA. stainless steel, with No. 4 finish on all exposed surfaces. The hood shall include UL/ULC listed grease filters mounted in an integral stainless steel rack inclined at 45 degrees. The filter rack shall include a full length stainless steel grease gutter and grease cup.

The Dynaflow plenum provides all the fresh air required for the commercial kitchen. The fresh air is routed to three (3) regions within the boundaries of the appliances. Each region includes an aerodynamically designed s/s perforated discharge panel.

The first (1) region discharges through a full length s/s panel located at the bottom of the Dynaflow plenum. Fresh air is directed through the Comfort Tuning Blade (CTB) towards the appliances providing maximum exhaust air reduction. The second (2) Region discharges through a full length s/s angular panel located at the bottom front of the Dynaflow plenum. The fresh air is directed towards the chef to provide a more comfortable work environment in front of the hood.

The third (3) region provides horizontal discharge of fresh air through a s/s perforated panel out the front of the hood into the kitchen. The third region provides the exact amount of fresh air to balance the kitchen and ensure optimum capture. The s/s front discharge shall include multiple s/s perforated panels every 24" (610mm) long across the front face of the hood. A manually operated Internal Blade (IB) damper shall be located behind each front s/s discharge panel. The CTB and IB dampers are field adjustable through the lower s/s discharge panel. The hood shall have _____ incandescent/fluorescent/recessed incandescent lights evenly spaced along the length of the hood.

Engineering Data

Item Number: _____
 Model Number: FNMBM _____
 Number of Sections: _____
 Hood Length: _____
 Hood Width: _____
 Lights: _____
 Exhaust Volume: _____
 No. of Exhaust Duct Collars: _____
 Size of Exhaust Duct Collar: _____
 Exhaust Static Pressure: _____
 Supply Volume: _____
 Supply No. of Duct Collars: _____
 Supply Size of Duct Collar: _____
 Supply Static Pressure: _____
 SideFlow LEFT: _____
 SideFlow RIGHT: _____

fnmbm