

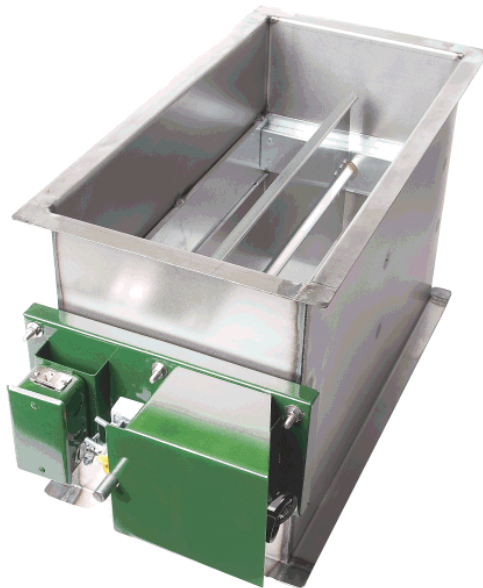

Spring Air

Solutions for Energy Savings

Zoneflow Engineering, Installation, and Maintenance Manual



Spring Air Systems Inc., Oakville, Ontario
Phone (905) 338-2999, Fax (905) 338-0179, info@springairsystems.com
www.springairsystems.com

Zoneflow Engineering, Installation, and Maintenance Manual

Introduction	1
What is a ZM Zoneflow?	1
ZM Zoneflow Operation	2
ZM Zoneflow for automatic air balancing	2
ZM Zoneflow for demand ventilation: Truflow Zoneflow panels	4
Truflow Zoneflow System Design	5
Truflow Zoneflow One (1) kitchen panel	5
Truflow Zoneflow Two (2) kitchen panel	8
ZM Zoneflow J-Box Wiring Schematic	11
ZM Zoneflow Spring Air Hood Section View	11
Top View three (3) ZM Zoneflow damper positions	13
What is a ZH Zoneflow?	14
Zoneflow Dimensions	16
Zoneflow Installation	19
Zoneflow Maintenance	20
Schedule for Inspection	20
Cleaning	22
Sample Specification	24

Zoneflow Engineering, Installation, and Maintenance Manual

Introduction

The Spring Air Systems ZoneFlow is designed to be installed in a commercial kitchen NFPA-96 central exhaust fan duct system up stream of each hood to automatically or manually modulate and/or balance the exhaust air volume between the multiple hoods connected to the common fan.

The Zoneflow is available in two types. ZM Zoneflow with automatic modulating control damper and ZH Zoneflow with manually adjustable control damper.

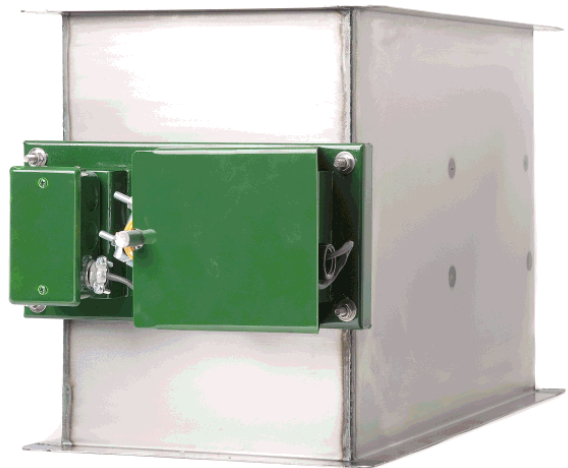

*Picture of ZM Vertical Zoneflow
Figure 1*

What is a ZM Zoneflow?

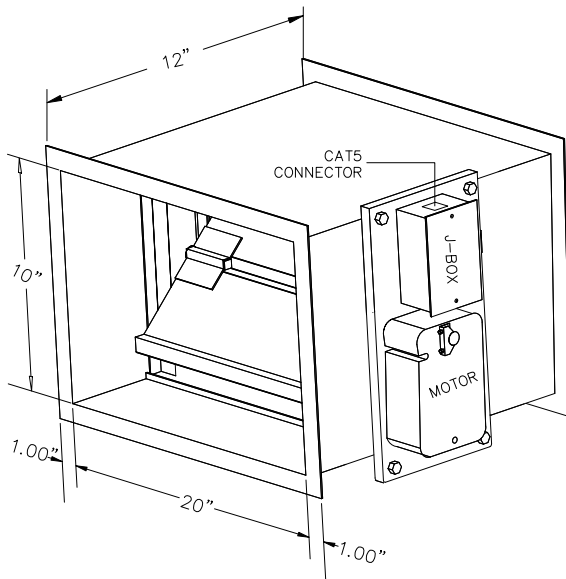

*Dimensional Isometric of Horizontal ZM Zoneflow
Figure 2*

The ZM ZoneFlow is a UL/ULC listed balancing damper designed for a Commercial Kitchen NFPA-96 grease duct. The ZM Zoneflow can be supplied loose to be welded into the kitchen grease duct between the hood and exhaust fan or welded directly to the exhaust duct collar of any Spring Air Systems hood. The ZM Zoneflow provides automatic modulation of the commercial kitchen hood exhaust volume.

The ZM Zoneflow Description:

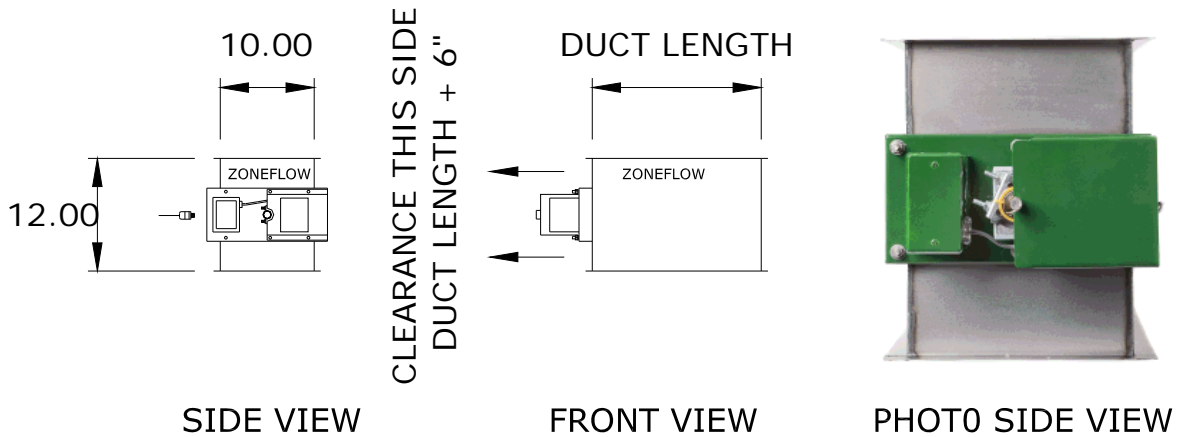

*ZM Zoneflow 10" wide duct collar
Figure 3*

The ZM ZoneFlow is 12" deep in the direct of exhaust air flow and matches the length and width dimensions of the hood exhaust duct collar. The outside casing is constructed of 16 GA. continuously welded cold rolled steel. The inlet and outlet of the ZM ZoneFlow has a 1" perimeter flange for welding to the NFPA-96 exhaust duct or the kitchen exhaust hood duct collar. The ZM ZoneFlow assembly includes a removable access door on the side of the ZM Zoneflow duct section. The access door is made of 16 GA carbon steel and bolted to the ZM Zoneflow duct section and sealed with high temperature gasket. The access door is removable for inspection and damper and interior duct. Mounted on the access door is a modulating motor U bolted to the internal control damper shaft. The modulating motor is provided with a protective, painted, steel shield. The modulating motor is factory wired to a J-Box also mounted on the access door. Power and control signal are provided through a CAT5 plug on the J-box. The modulating motor requires 24VDC or 24VAC power and a 4-20 milliamp control signal.

ZM Zoneflow Operation

A. ZM Zoneflow for automatic air balancing:

Field balancing a commercial kitchen exhaust system is very difficult when multiple hoods are connected to a single central exhaust fan. In the schematic below the first hood closest to the fan will exhaust too much air and the last hood in the system typically will be starved for exhaust air. The ZM Zoneflow provides a simple solution to automatically balance each hood in the central single fan exhaust system. The ZM Zoneflow is installed in each hood exhaust duct collar.

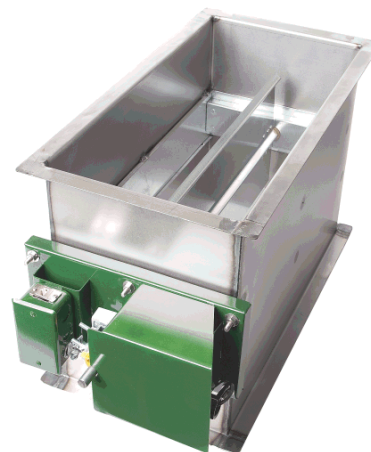

*ZM Zoneflow with damper shield and
CAT5 J-Box
Figure 4*

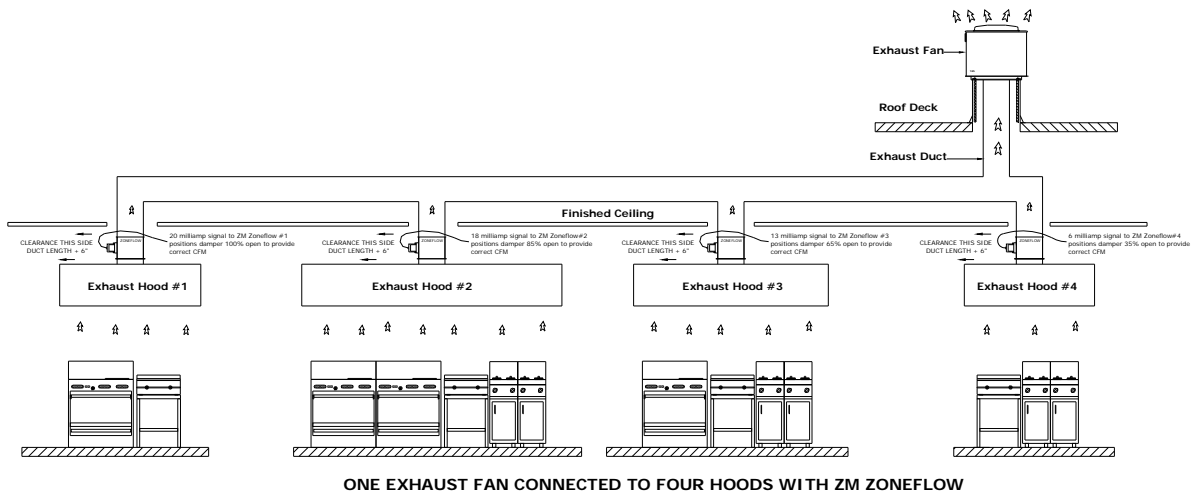

*ZM Zoneflow, Hood, Fan and Ductwork Schematic
Figure 3*

The Duct and Hood Schematic shown above is a central exhaust fan with four commercial kitchen hoods. Exhaust hood #4 closest to the fan would have too much exhaust air while exhaust hood #1 furthest away from the central fan would be starved for exhaust air. By proportionally closing down ZM Zoneflow #4, #3 and #2 the correct amount of exhaust air is provided to hood #1.

The ZM Zoneflow control damper motor requires 24VDC power and a 4-20milliamp control signal. A 4 milliamps signal drives the control damper to the lowest position, while a 20 milliamp signal opens the control damper 100%. Modulating each ZM Zoneflow damper will set the proper air flow to each hood connected to the central exhaust fan.

A 4-20milliamp signal is sent to each ZM Zoneflow installed in each hood duct collar from a Spring Air Systems RPD-P11_ZM panel. The signal is modulated to position the control damper to provide the correct amount of CFM (l/s) for each hood.

The ZM Zoneflow in hood #4 closest to the central fan receives a 6 milliamp signal to close the control damper to 35% to provide the design CFM. The ZM Zoneflow in hood #1 furthest from the central fan is receives a 20 milliamp signal to open the control damper to 100% to provide the design CFM. Each ZM Zoneflow is adjusted accordingly to provide the exact exhaust required for each hood.

The Spring Air Systems RPD-P11-ZM Zoneflow control panel below makes ZM Zoneflow setup even easier. The RPD-P11-ZM provides an adjustable 4-20milliamp signal for each ZM Zoneflow. In addition the RPD-P11-ZM is a complete control system for the commercial kitchen operation. The panel controls all aspects of the kitchen ventilation system. Each ZM Zoneflow damper position is adjusted by rotating a dial inside the panel at startup. In addition to controlling the ZM Zoneflow the panel interlocks to all other components required to operate a commercial kitchen operation.

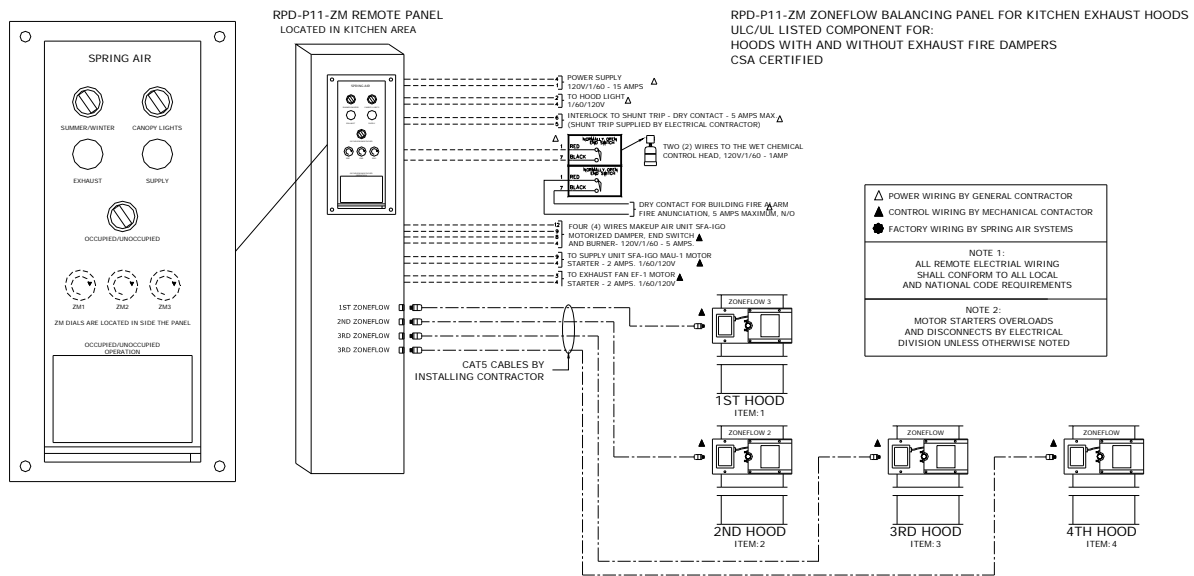

*RPD-11-ZM Electrical schematic for four (4) hoods with ZH Zoneflow,
And common central exhaust fan
Figure 4*

B. ZM Zoneflow for demand ventilation: TRUFLOW ZONEFLOW

The average commercial kitchen exhaust system operates 12 to 18 hours per day. Today's kitchen systems exhaust at 100% capacity whenever they are turned on regardless of that number of appliances or amount of cooking that is going on under the hood. The cook will arrive at 7:00 a.m. in the morning and switch the system on for the day. The system is not shut off until the last person leaves the kitchen at the end of the day. The reality is that the amount of actual high capacity cooking is a very small part of the total operating day. Unfortunately the exhaust and the supply (which heats and cools the fresh air to replace the exhaust from the kitchen) operate continuously at full volume throughout the day.

The Truflow-Zoneflow system regulates the amount of air exhausted from the kitchen to match the amount of cooking. The Truflow Zoneflow is designed for central exhaust fan systems with multiple hoods connected. As more appliances under each hood are used the total exhaust and supply volume increases, as fewer appliances under each hood are used the total exhaust and supply volume decreases.

The Truflow-Zoneflow commercial kitchen variable exhaust/supply control has been designed to change kitchen exhaust forever. Truflow-Zoneflow will automatically reduce the exhaust and supply air into the kitchen whenever appliances are not used at full capacity. When the appliances are not used and the heat is turned down or off the Truflow-Zoneflow automatically senses this reduction and decreases the amount of exhaust and supply to match exactly what's



*Truflow Zoneflow Touchscreen Panel
Figure 5*

happening under the each exhaust hood. The Truflow-Zoneflow hood duct collar mounted J-Couple monitors the exhaust temperature, which fluctuates based on the amount of appliances operating under the exhaust hood. As the amount of cooking increases the exhaust duct temperature rises and reaches an equilibrium temperature. The current equilibrium temperature is affected by many variables.

- Total exhaust volume
- BTU rating of each appliance
- Total Volume of makeup
- Temperature of Makeup air
- Where the makeup air is introduced back into the kitchen,
- Type of hood over the appliance.

The Truflow-Zoneflow automatically modulates the exhaust and supply to suit the actual cooking operation at any given time during the cooking day. When the hood duct collar mounted J-couple senses a temperature rise a signal is sent to the ZM Zoneflow to open the control damper to allow more exhaust air from the hood. At the same time the Truflow-Zoneflow sends another signal to the exhaust and/or supply variable speed drive to increase the frequency of the motor to provide more exhaust and supply air.

Truflow Zoneflow System Design

The Truflow Zoneflow is available for one (1) kitchen (one central exhaust fan) and two (2) kitchen (two central exhaust fans) arrangements.

One (1) kitchen panel: Panel is interlocked to one central exhaust fan and/or one supply fan with up to (12) twelve hoods with ZM Zoneflow.

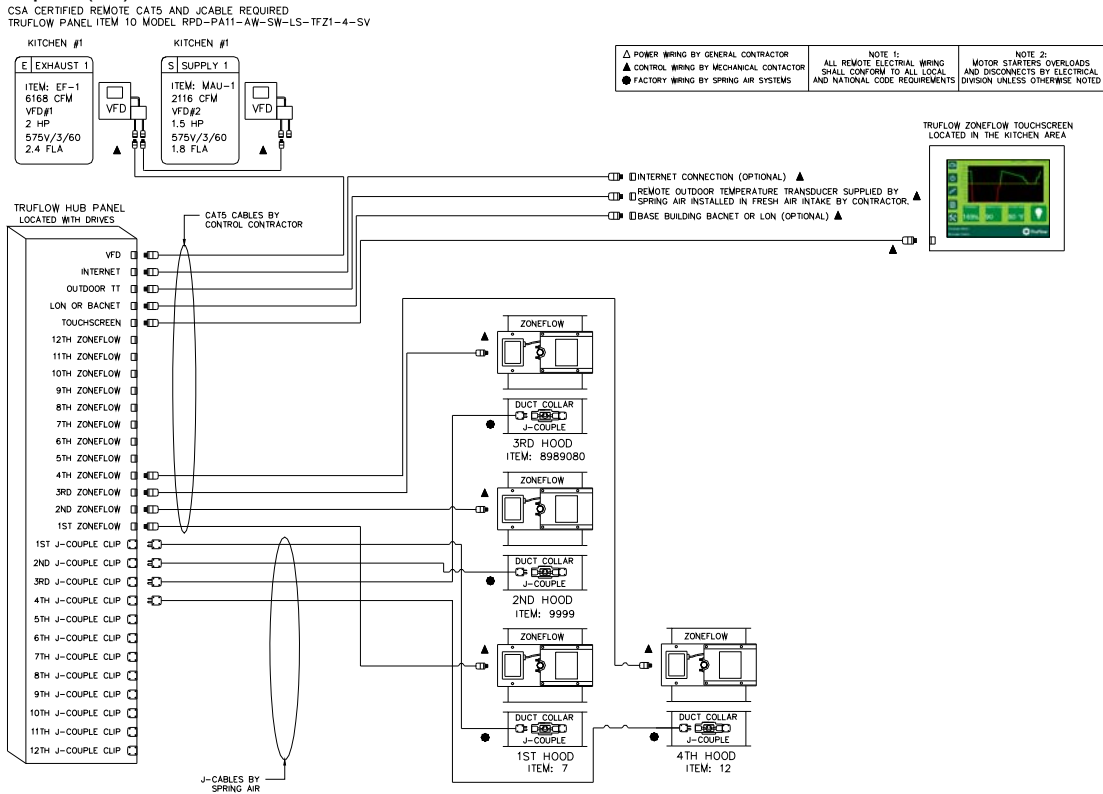

*Zoneflow Truflow CAT5 and J-Cable Schematic
Figure 6*

The Truflow Zoneflow schematic above outlines field installed CAT5 and J-Cable wiring to each component of a One Kitchen (One exhaust fan and one supply fan) Truflow Zoneflow panel. The schematic shows one exhaust fan drive and one supply fan drive, four hood exhaust duct collars with J-Couples and Zoneflow Dampers. The drives will be modulated based on the temperature within the hood duct collars.

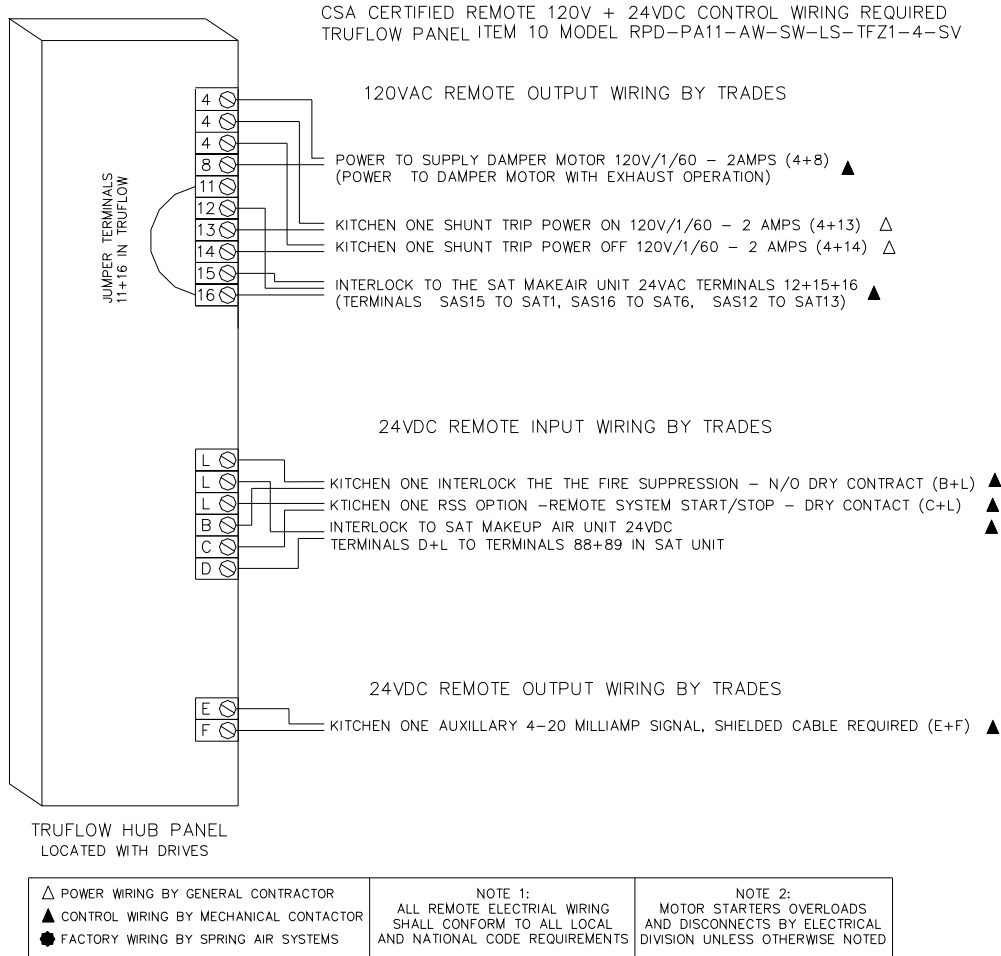

*Zoneflow Truflow 120V and 24V control wiring schematic
Figure 7*

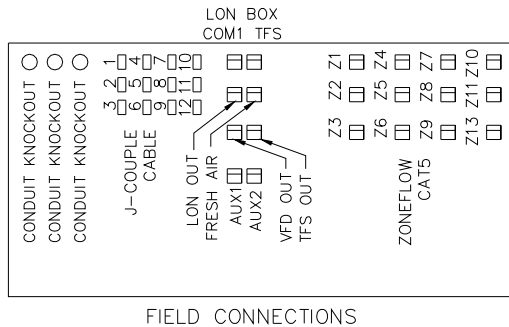

The Truflow Zoneflow schematic above indicates the 24V and 120V input and output control wiring required for the One Kitchen central exhaust fan system. The exhaust and supply fan operation are both controlled from this panel.

Top of Truflow Zoneflow Hub Panel Figure 8

TRUFLOW-ZONEFLOW PANEL FOR KITCHEN EXHAUST HOODS
ULC/UL LISTED COMPONENT FOR: HOODS WITH AND WITHOUT EXHAUST FIRE DAMPERS
CSA CERTIFIED REMOTE POWER WIRING REQUIRED
TRUFLOW PANEL ITEM 10 MODEL RPD-PA11-AW-SW-LS-TFZ1-4-SV

TRUFLOW HUB PANEL

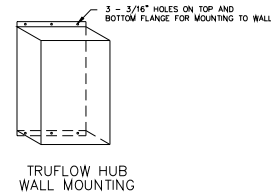
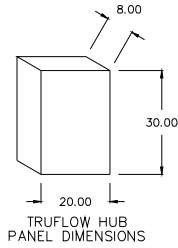
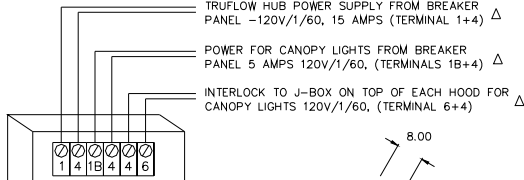

TRUFLOW HUB PANEL
LOCATED WITH DRIVES

TRUFLOW HUB
WALL MOUNTING

WIRING TERMINALS ON VARIABLE FREQUENCY DRIVE(S) FOR TRADES

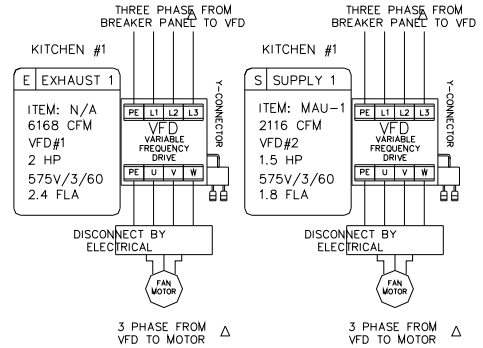

<p>△ POWER WIRING BY GENERAL CONTRACTOR</p> <p>▲ CONTROL WIRING BY MECHANICAL CONTACTOR</p> <p>● FACTORY WIRING BY SPRING AIR SYSTEMS</p>	<p>NOTE 1: ALL REMOTE ELECTRICAL WIRING SHALL CONFORM TO ALL LOCAL AND NATIONAL CODE REQUIREMENTS</p>	<p>NOTE 2: MOTOR STARTERS OVERLOADS AND DISCONNECTS BY ELECTRICAL DIVISION UNLESS OTHERWISE NOTED</p>
---	---	---

Zoneflow Truflow power wiring Figure 9

RUFLOW ZONEFLOW TOUCHSCREEN

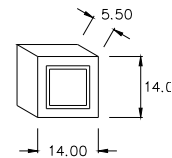
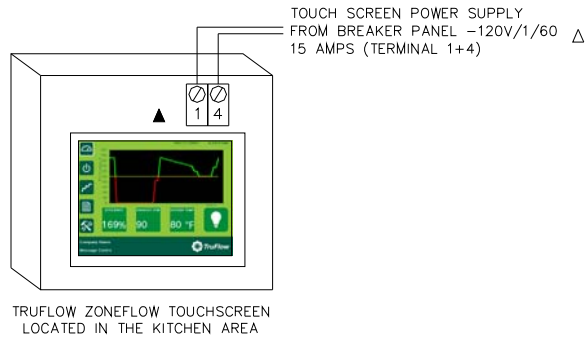

TOUCHSCREEN
PANEL DIMENSIONS

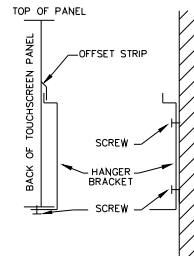

TOUCHSCREEN
WALL BRACKET

Zoneflow Truflow power wiring to Truflow Zoneflow Touchscreen panel Figure 10

The Truflow Zoneflow wiring schematic above shows all power wiring required to each component in a One Kitchen commercial kitchen exhaust system.

Two (2) kitchen panels: Panels are interlocked to two central exhaust fan, one or two supply fan and up to 12 ZM Zoneflow. The two (2) exhaust fans operated independently.

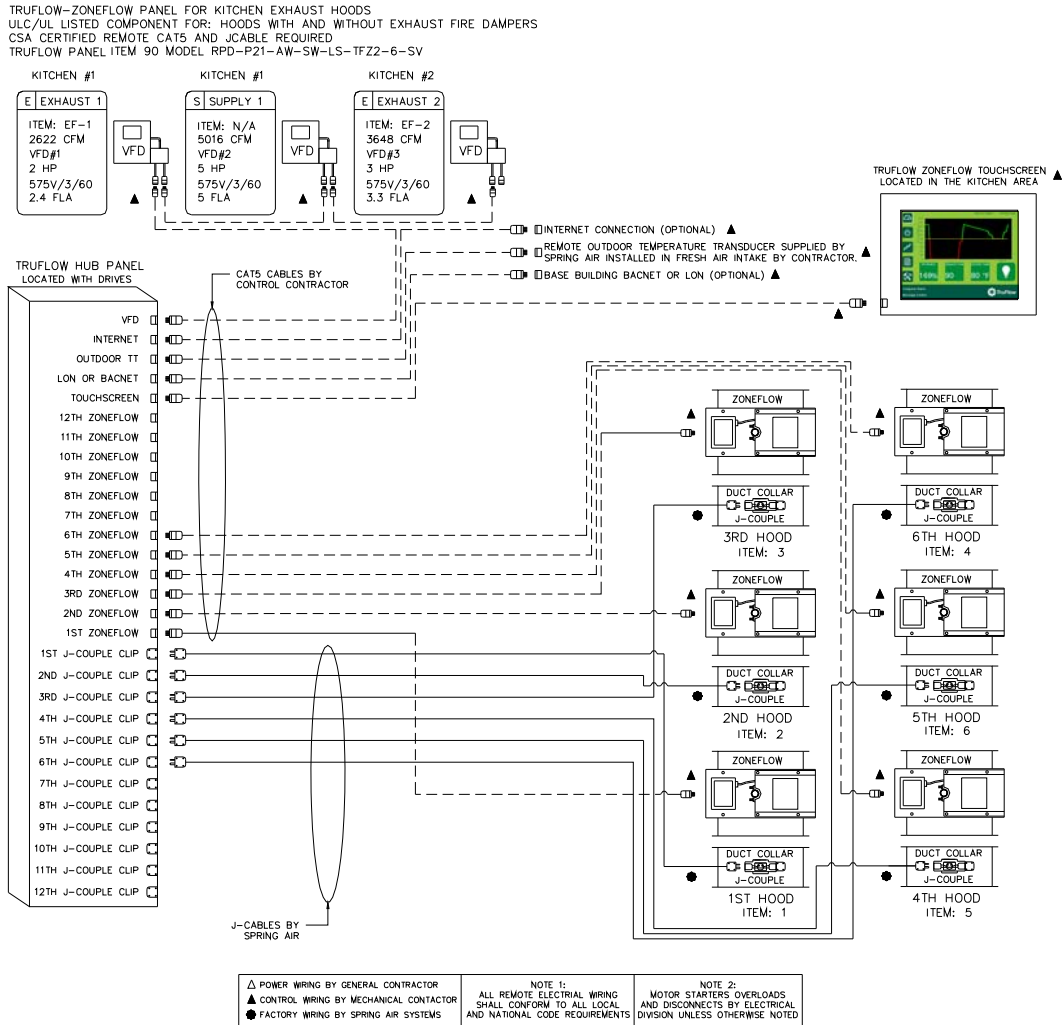

*Zoneflow Truflow CAT5 and J-Cable wiring schematic for 6 - Zoneflow, hoods and two (2) central fan
 Figure 11*

The Truflow Zoneflow schematic above outlines field installed CAT5 and J-Cable wiring to the components of a Two Kitchen System with two central exhaust fans and one common supply fan... The schematic shows one exhaust fan drive and one supply fan drive, four exhaust duct collars with J-Couples and Zoneflow Dampers. The drives will be modulated based on the temperature within the hood duct collars.

TRUFLow-ZONEflow PANEL FOR KITCHEN EXHAUST HOODS
 ULC/UL LISTED COMPONENT FOR: HOODS WITH AND WITHOUT EXHAUST FIRE DAMPERS
 CSA CERTIFIED REMOTE 120V + 24VDC CONTROL WIRING REQUIRED
 TRUFLow PANEL ITEM 90 MODEL RPD-P21-AW-SW-LS-TFZ2-6-SV

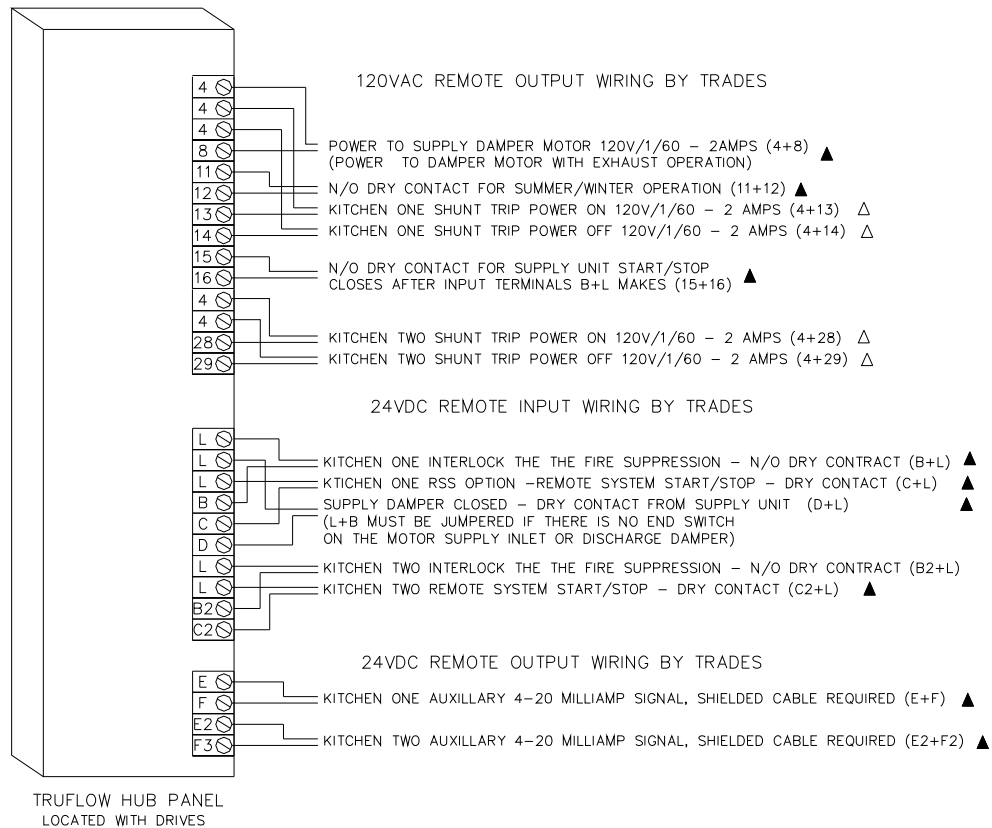

△ POWER WIRING BY GENERAL CONTRACTOR	NOTE 1: ALL REMOTE ELECTRICAL WIRING SHALL CONFORM TO ALL LOCAL AND NATIONAL CODE REQUIREMENTS	NOTE 2: MOTOR STARTERS OVERLOADS AND DISCONNECTS BY ELECTRICAL DIVISION UNLESS OTHERWISE NOTED
▲ CONTROL WIRING BY MECHANICAL CONTACTOR		
● FACTORY WIRING BY SPRING AIR SYSTEMS		

*Zonelflow Truflow 120V and 24V control wiring schematic for
 6 -Zonelflow, hoods and two (2) central fan
 Figure 12*

The Truflow Zonelflow schematic above indicates the 24V and 120V input and output control wiring required for the Two Kitchen system. The exhaust and supply fan operation are both controlled from this panel.

TRUFLOW-ZONEFLOW PANEL FOR KITCHEN EXHAUST HOODS
 ULC/UL LISTED COMPONENT FOR: HOODS WITH AND WITHOUT EXHAUST FIRE DAMPERS
 CSA CERTIFIED REMOTE POWER WIRING REQUIRED
 TRUFLOW PANEL ITEM 90 MODEL RPD-P21-AW-SW-LS-TF22-6-SV

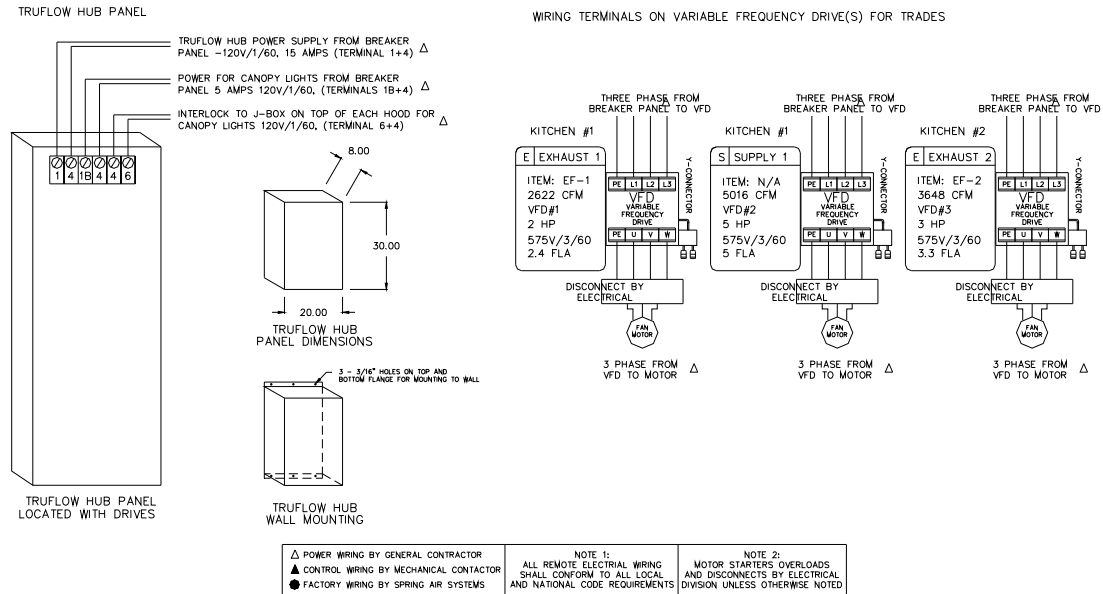

*Zoneflow Truflow Power wiring schematic for 6 -Zoneflow, hoods and two (2) central fans
 Figure 13*

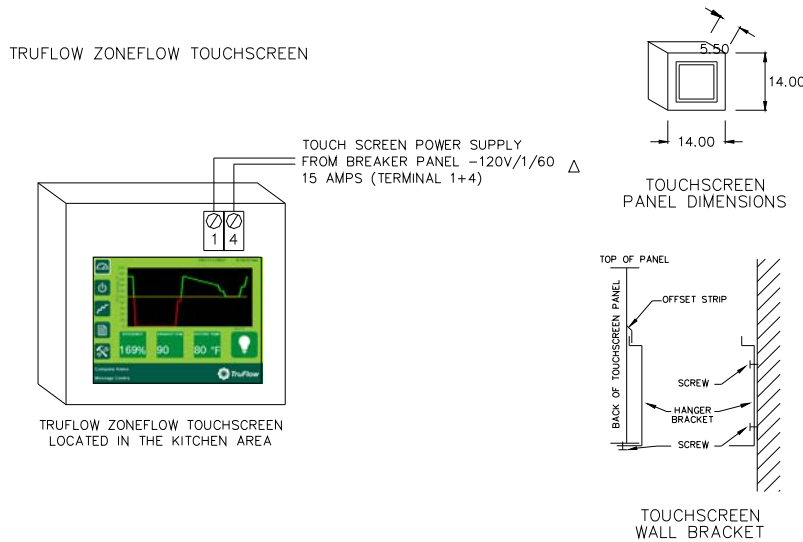

*Zoneflow Truflow Touchscreen for 6 -Zoneflow, hoods and two (2) central fans
 Figure 14*

The Truflow Zoneflow wiring schematic above shows all power wiring required to each component in a Two Kitchen commercial kitchen exhaust system.

ZM Zoneflow J-Box Wiring Schematic

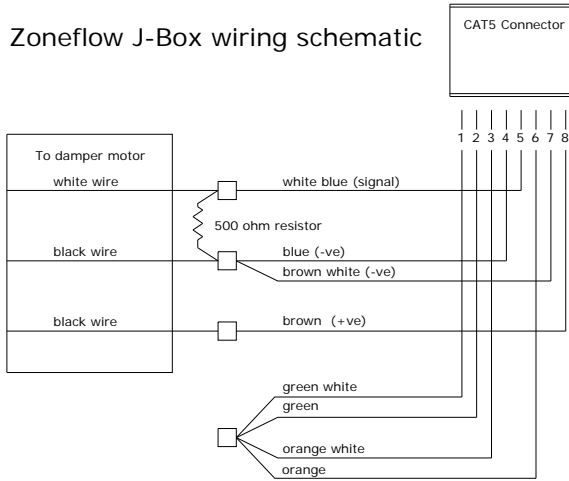

The Zoneflow is 24VDC power and signal is supplied through a CAT5 connector on the Zoneflow J-Box. The CAT5 connector pin-out and wire color coding is shown in the Zoneflow J-Box wiring schematic. The J-Box has an internal 500 ohm resistor and is wired directly to the damper motor. The signal supplied is 4-20 milliamp to drive the damper motor.

*ZM Zoneflow J-Box internal wiring and CAT5 Pin-Out
Figure 15*

ZM Zoneflow Spring Air Hood Section View

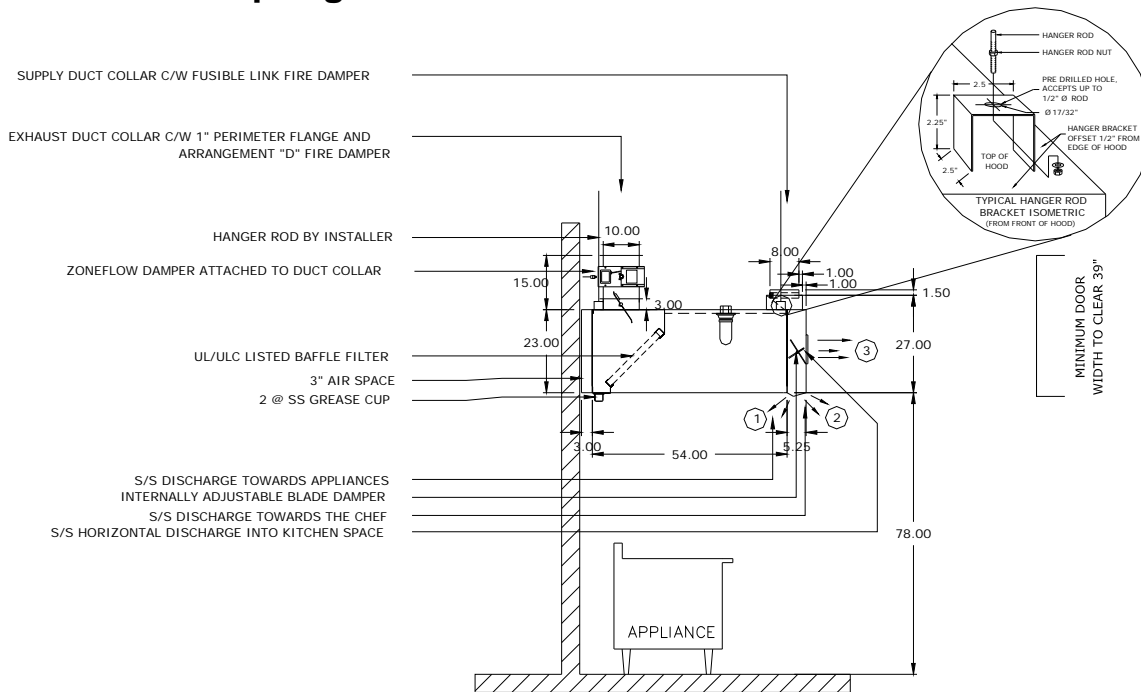

*Section view of FDBMB-ZM hood with vertical ZM Zoneflow damper mounted on duct collar
Figure 16*

The section view above shows a Spring Air Systems Dynaflow FDBMB with a Zoneflow mounted directly to the duct collar. The duct collar is at the back of the hood and the Zoneflow extends 15" above the roof of the hood requiring a building door width of at least 39" for passage into the building.



The ZM Zoneflow controls are mounted on the access door on the left side as viewed from the front of the hood. The ZM Zoneflow requires clearance of 6" plus the length of the duct clearance on this side. This provides enough space to remove the interior balancing damper for inspection and cleaning. For example if the duct collar is 10" x 30" the clearance required on the left side of the Zoneflow is 6" + 30" = 36".

*ZM Zoneflow with access remove and balancing damper exposed from duct section.
Figure 17*

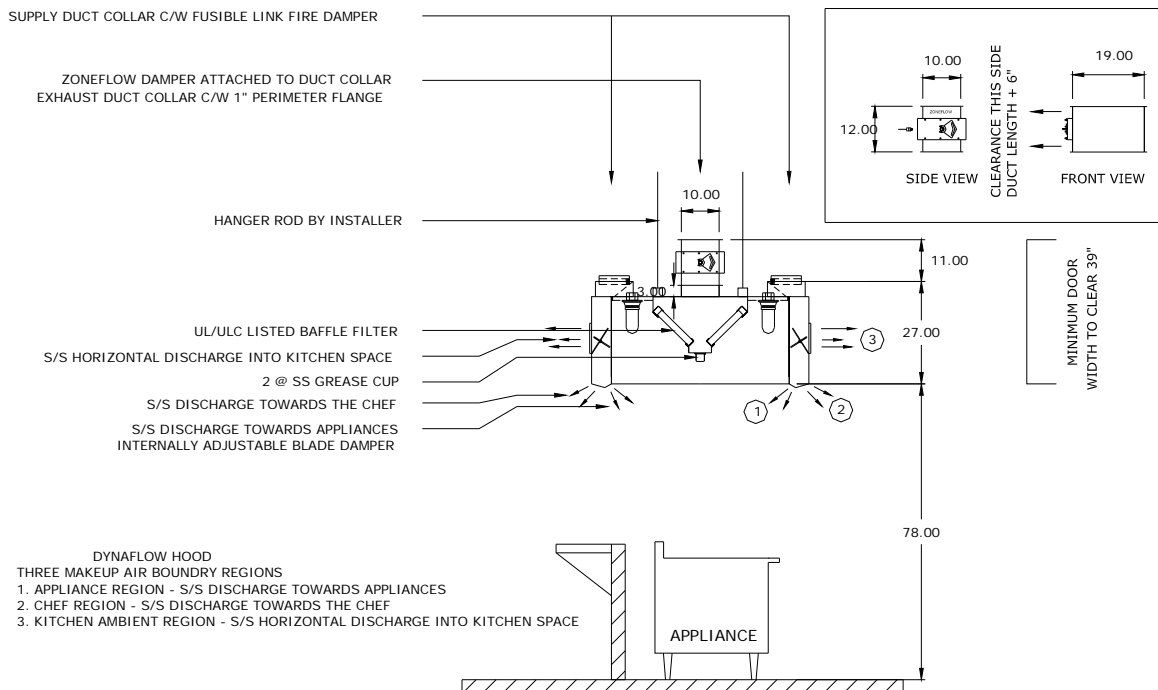

*FNDSMB-ZM Section View with Zoneflow
Figure 18*

The section view above shows a Spring Air Systems Dynaflow FDBMB-ZM with a Zoneflow mounted directly to the duct collar. The duct collar is at the front of this hood and the Zoneflow extends 15" above the roof of the hood requiring a building door width of at least 41" for passage into the building.

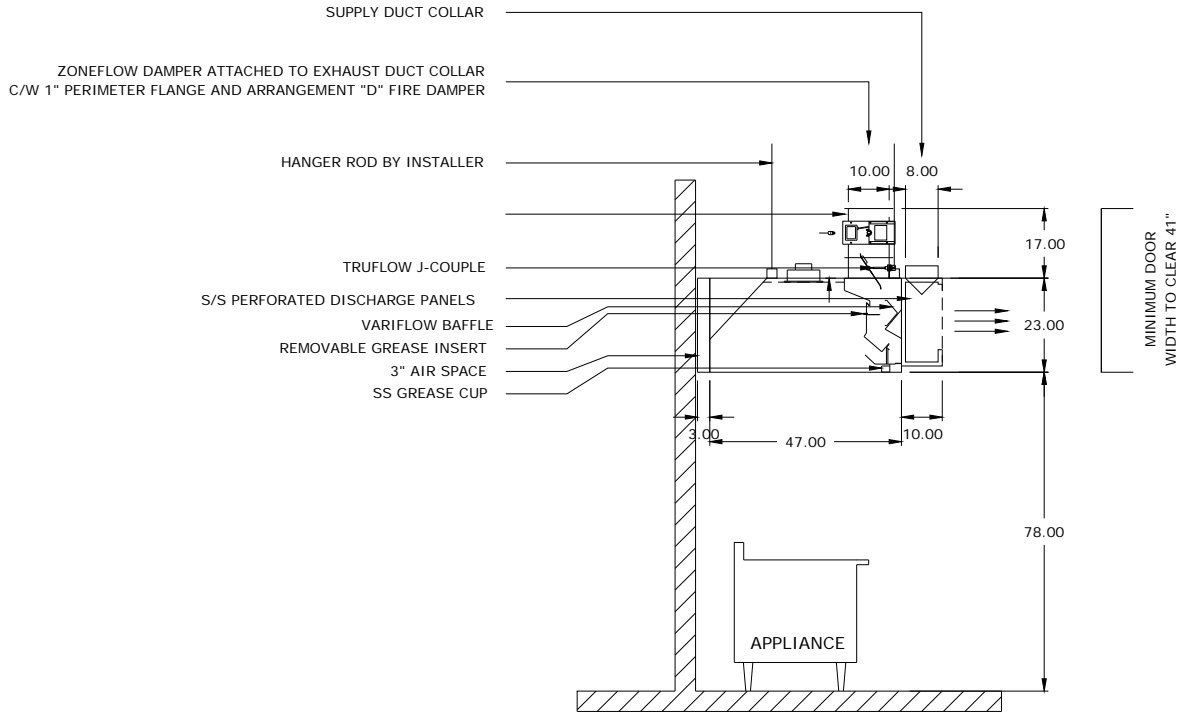

*DDBFMP-ZM Revlow section view of with vertical ZM Zoneflow damper
Figure 19*

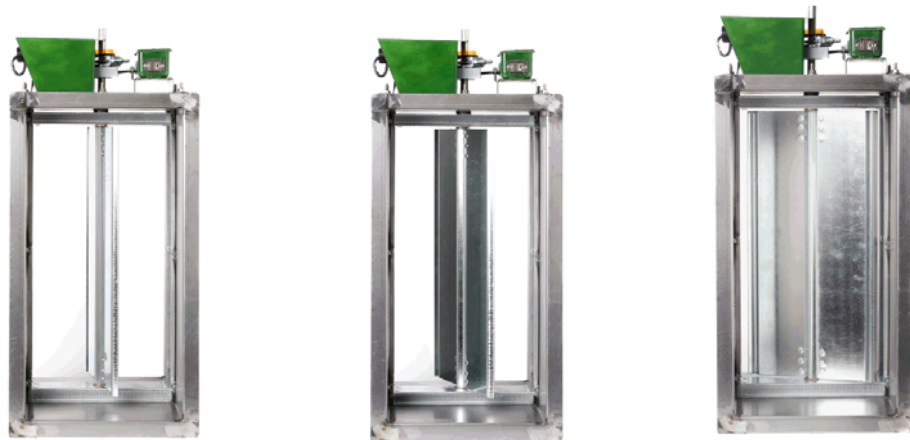

**MAXIMUM
OPEN**

**PARTIAL
OPEN**

**MAXIMUM
CLOSED**

*Top View of ZM Zoneflow in various damper positions
Figure 20*

What is a ZH Zoneflow?

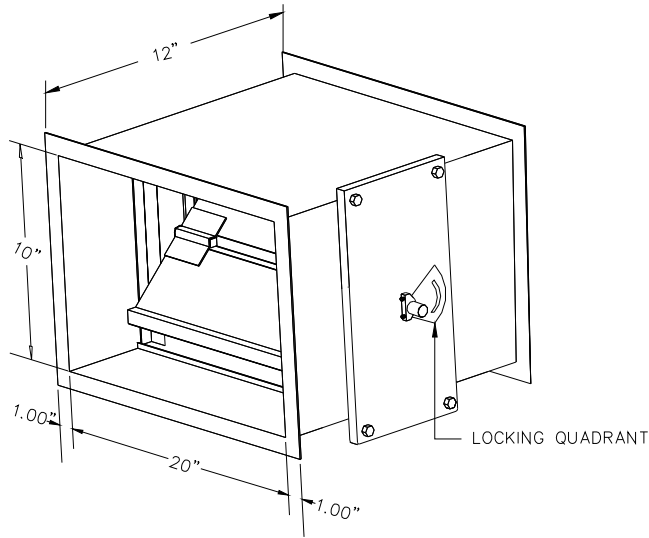

The ZH ZoneFlow is a UL/ULC listed manual balancing damper designed for a NFPA-96 grease duct. The ZH Zoneflow can be supplied loose to be welded into the grease duct between the hood and exhaust fan or welded directly to the exhaust duct collar of any Spring Air Systems hood. The ZH Zoneflow damper position is manually adjusted to balance a series of individual hoods connected to one exhaust fan

*ZH Zoneflow Isometric
Figure 21*

The ZH Zoneflow Description:

The ZH ZoneFlow is 12" deep in the direction of exhaust air flow and matches the length and width dimensions of the hood exhaust duct collar. The outside casing is constructed of 16 GA. continuously welded cold rolled steel. The inlet and outlet of the ZM ZoneFlow has a 1" perimeter flange for welding to the NFPA-96 exhaust duct or the kitchen exhaust hood duct collar.

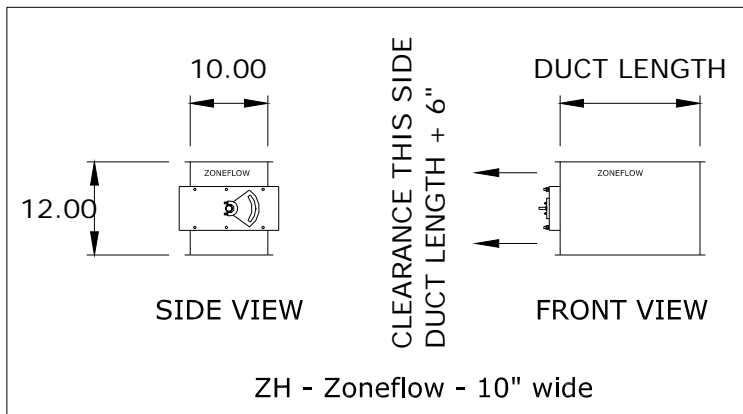

*ZH Zoneflow Dimensions
Figure 22*

The inlet and outlet of the ZM ZoneFlow has a 1" perimeter flange for welding to the NFPA-96 exhaust duct or the kitchen exhaust hood duct collar. The ZH ZoneFlow assembly includes a removable access door on the side of the ZH Zoneflow duct section. The access door is made of 16 GA carbon steel and bolted to the ZM Zoneflow duct section and sealed with high temperature gasket. The access door is removable for inspection and damper and interior duct. Mounted on the access door is locking quadrant, U bolted to the internal control damper shaft.

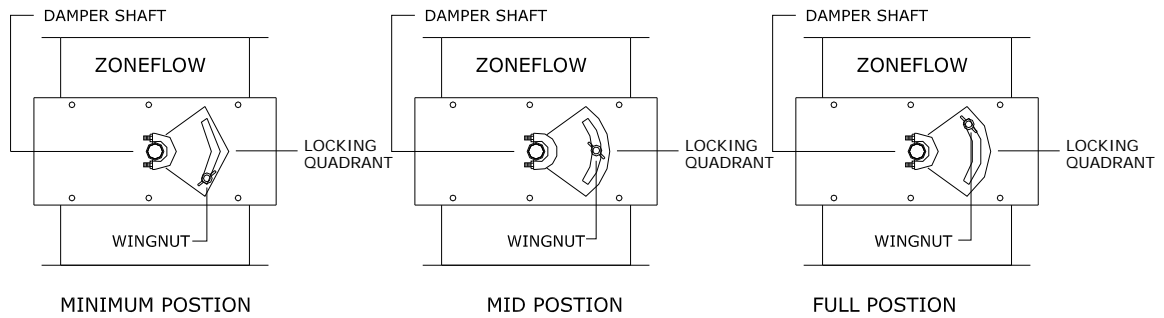

*ZH Zoneflow Damper Adjustment
Figure 23*

Adjusting the locking quadrant: The ZH Zoneflow is factory shipped set in the minimum position. Unscrew the wing-nut on the locking quadrant. Slight the wing-nut and shaft along the opening in the quadrant to the damper position required. Once in position tighten the wing-nut to lock damper in position. The top position is the maximum open position.

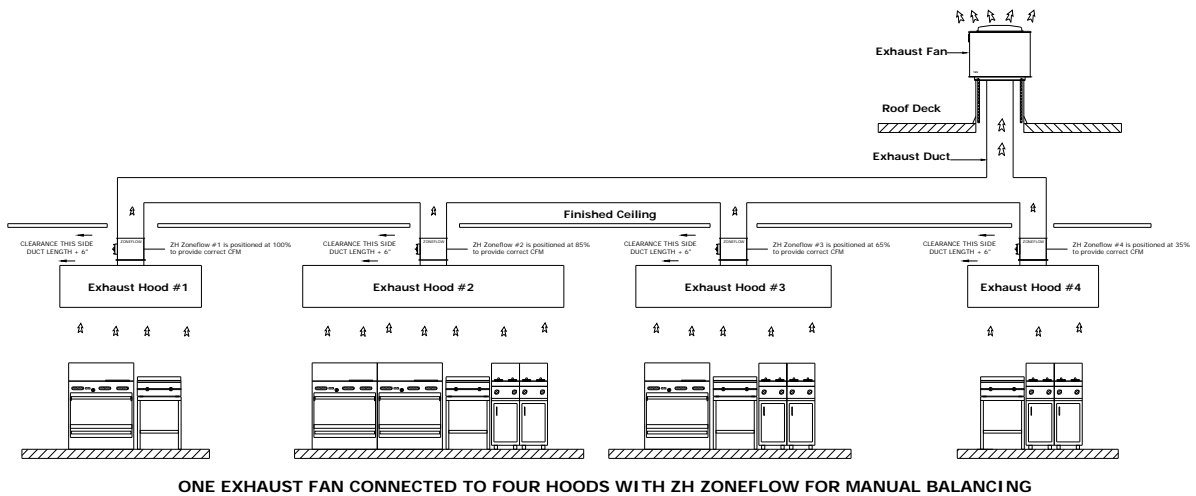

*ZH Zoneflow, Hood, Fan and Ductwork Schematic
Figure 24*

The Duct and Hood Schematic shown above is a central exhaust fan with four commercial kitchen hoods. Each hood has a ZH Zoneflow on each hood. The hood #4 closest to the fan would have too much exhaust air while exhaust hood #1 furthest away from the central fan would be starved for exhaust air. By manually adjusting the locking quadrant on the ZH Zoneflow #4, #3 and #2 the correct amount of exhaust air is provided at each hood.

SPRING AIR SYSTEMS INC. HOODS ARE BUILT IN ACCORDANCE WITH UNDERWRITERS LABORATORIES UL710 STANDARD *EXHAUST HOODS WITHOUT EXHAUST FIRE DAMPERS*, UL FILE NO. MH45396, MODEL FN. UNDERWRITERS LABORATORIES OF CANADA STANDARD S646-98, *HOODS FOR COMMERCIAL AND INSTITUTIONAL KITCHENS*, ULC FILE NO. CR1907, CURRENT EDITIONS OF NFPA-96, INTERNATIONAL MECHANICAL CODE AND IN ACCORDANCE WITH UL710

ITEM: 1.1, MODEL: FN-DB-8.50/11

SECTION VIEW
HOOD IS CONNECTED TO EXHAUST FAN (EF-1)



ITEM NO.	WEIGHT (LBS)	FILTER TYPE	QTY	SIZE
1.1	722 lbs	STAINLESS STEEL	8	20X20

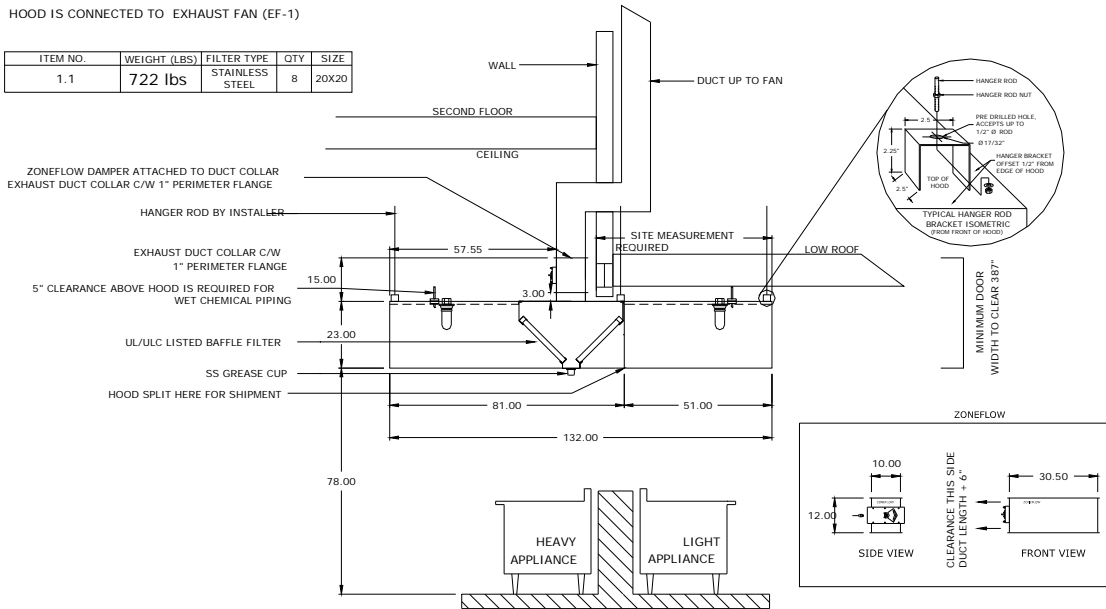

*Typical ZH Zoneflow Double Row Filter Hood Schematic
Figure 25*

The schematic above shows a FNDB-ZH Zoneflow hood section view. The ZH Zoneflow is attached directly to the island filter hood. The hood is split in two sections for shipping.



The ZH Zoneflow pictured to the left has the access door and locking quadrant removed and the damper is partial removed from the steel duct housing. Note the high temperature gasket around the access door flange.

*ZH Zoneflow with access door removed
Figure 26*

Zoneflow Dimensions

The height (in the direction of air flow) of all ZH and ZM Zoneflow dampers is 12" (305mm). The width and length match the width and length of the Spring Air Systems hood exhaust duct collar. The two charts below indicated width and lengths of all exhaust duct collars. Chart No. 1 is for all Revlow hood exhaust duct collars and Chart No.2 is for all other hood exhaust collars.

RevLow Exhaust Volume Vs Zoneflow Duct Size

Exhaust Volume		Duct Collar Size		Exhaust Volume		Duct Collar Size	
CFM	l/s	W x L in x in	W x L mm x mm	CFM	l/s	W x L in x in	W x L mm x mm
450	212	10 x 4	254 x 102	3500	1652	10 x 33.5	254 x 851
500	236	10 x 4.5	254 x 114	3625	1711	10 x 34.5	254 x 876
625	295	10 x 6.0	254 x 152	3750	1770	10 x 36.0	254 x 914
750	354	10 x 7.0	254 x 178	3875	1829	10 x 37.0	254 x 940
875	413	10 x 8.0	254 x 203	4000	1888	14 x 27.0	356 x 686
1000	472	10 x 9.5	254 x 241	4125	1947	14 x 28.0	356 x 711
1125	531	10 x 10.5	254 x 267	4250	2006	14 x 29.0	356 x 737
1250	590	10 x 12.0	254 x 305	4375	2065	14 x 30.0	356 x 762
1375	649	10 x 13.0	254 x 330	4500	2124	14 x 30.5	356 x 775
1500	708	10 x 14.0	254 x 356	4625	2183	14 x 31.5	356 x 800
1625	767	10 x 15.5	254 x 394	4750	2242	14 x 32.5	356 x 826
1750	826	10 x 16.5	254 x 419	4875	2301	14 x 33.0	356 x 838
1875	885	10 x 18.0	254 x 457	5000	2360	14 x 34.0	356 x 864
2000	944	10 x 19.0	254 x 483	5125	2419	14 x 35.0	356 x 889
2125	1003	10 x 20.	254 x 508	5250	2475	14 x 36.0	356 x 914
2250	1062	10 x 21.5	254 x 546	5375	2537	14 x 36.5	356 x 927
2375	1121	10 x 22.5	254 x 572	5500	2596	14 x 37.5	356 x 953
2500	1180	10 x 24.0	254 x 610	5625	2655	14 x 38.5	356 x 978
2625	1239	10 x 25.0	254 x 635	5750	2714	14 x 39.0	356 x 991
2750	1298	10 x 26.0	254 x 660	5875	2773	14 x 40.0	356 x 1016
2875	1357	10 x 27.5	254 x 699	6000	2832	14 x 41.0	356 x 1041
3000	1416	10 x 28.5	254 x 724	6125	2891	14 x 42.0	356 x 1067
3125	1475	10 x 30.0	254 x 762	6250	2950	14 x 42.5	356 x 1080
3250	1534	10 x 31.0	254 x 787	6375	3008	16 x 38.0	406 x 965
3375	1593	10 x 32.0	254 x 813	6500	3067	16 x 39.0	406 x 991

1. If exact exhaust volume is not indicated use duct size closest to required exhaust.
2. Model B water wash hoods and dry extractors have 1.5" W.C. (0.38kPa) for exhaust flow rates from 90 to 450 CFM/ft (140 to 700 l/s/m)

Chart No. 1

Exhaust Volume Vs Zoneflow Duct Size - All Ventilators

Exhaust Volume		Duct Collar Size		Exhaust Volume		Duct Collar Size	
CFM	l/s	W x L in x in	W x L mm x mm	CFM	l/s	W x L in x in	W x L mm x mm
450	212	10 x 4	254 x 102	4000	1888	10 x 36	254 x 914
500	236	10 x 4.5	254 x 114	4125	1947	10 x 37	254 x 940
625	295	10 x 5.5	254 x 140	4250	2006	10 x 38	254 x 965
750	354	10 x 7	254 x 178	4375	2065	10 x 39	254 x 991
875	413	10 x 8	254 x 203	4500	2124	10 x 40.5	254 x 1029
1000	472	10 x 9	254 x 229	4625	2183	14 x 29.5	356 x 749
1125	531	10 x 10	254 x 254	4750	2242	14 x 30.5	356 x 775
1250	590	10 x 11	254 x 279	4875	2301	14 x 31.5	356 x 800
1375	649	10 x 12.5	254 x 318	5000	2360	14 x 32	356 x 813
1500	708	10 x 13.5	254 x 343	5125	2419	14 x 33	356 x 838
1625	767	10 x 14.5	254 x 368	5250	2475	14 x 33.5	356 x 851
1750	826	10 x 16	254 x 406	5375	2537	14 x 34.5	356 x 876
1875	885	10 x 17	254 x 432	5500	2596	14 x 35.5	356 x 902
2000	944	10 x 18	254 x 457	5625	2655	14 x 36	356 x 914
2125	1003	10 x 19	254 x 483	5750	2714	14 x 37	356 x 940
2250	1062	10 x 20	254 x 508	5875	2773	14 x 38	356 x 965
2375	1121	10 x 21.5	254 x 546	6000	2832	14 x 38.5	356 x 978
2500	1180	10 x 22.5	254 x 572	6125	2891	14 x 39	356 x 991
2625	1239	10 x 23.5	254 x 597	6250	2950	14 x 40	356 x 1016
2750	1298	10 x 25	254 x 635	6375	3008	16 x 36	406 x 914
2875	1357	10 x 26	254 x 660	6500	3067	16 x 36.5	406 x 927
3000	1416	10 x 27	254 x 686	6625	3125	16 x 37	406 x 940
3125	1475	10 x 28	254 x 711	6750	3185	16 x 38	406 x 965
3250	1534	10 x 29	254 x 737	6875	3244	16 x 38.5	406 x 978
3375	1593	10 x 30.5	254 x 775	7000	3303	16 x 39.5	406 x 1003
3500	1652	10 x 31.5	254 x 800	7125	3362	16 x 40	406 x 1016
3625	1711	10 x 32.5	254 x 826	7250	3421	16 x 41	406 x 1041
3750	1770	10 x 34	254 x 864	7375	3480	16 x 41.5	406 x 1054
3875	1829	10 x 35	254 x 889	7500	3539	16 x 42	406 x 1067

1. If exact exhaust volume is not indicated use duct size closest to required exhaust.
2. Model S, B, & B-S water wash hoods and dry grease extractors have 1.0" W.C. (0.25 Kpa) for exhaust flow rates from 150 to 400 CFM/ft (233 to 622 l/s/m)
3. Model DB water wash hoods and dry grease extractors have 1.13" W.C. (0.28 Kpa) for exhaust flow rates from 150 to 500 CFM/ft (233 to 776 l/s/m)

Chart No. 2

Zoneflow Installation

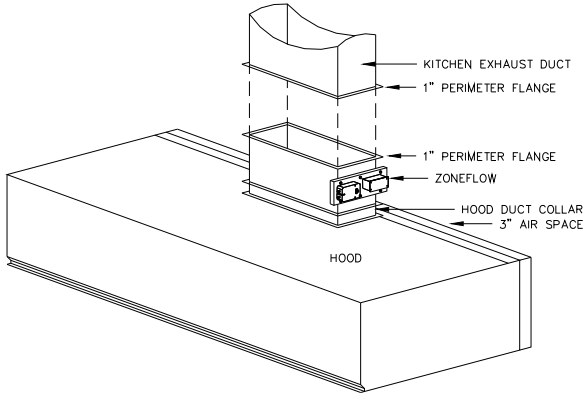

The Zoneflow is installed directly on the hood exhaust duct collar. Normally the Zoneflow ZH or ZM are factory welded to the hood exhaust duct collar prior to shipment.

The field connection to the Zoneflow requires all seams and joints, to be liquid-tight continuous welded.

*ZM Zoneflow Duct Connection
Figure 27*

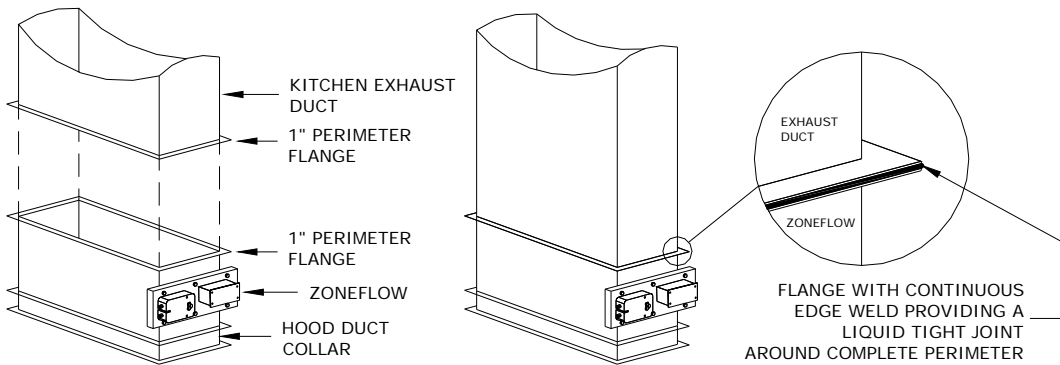

Exhaust duct matches size of Zoneflow including 1" perimeter flange

Continuously weld exhaust duct to the Zoneflow around perimeter liquid tight.

*ZM Zoneflow Flange Weld
Figure 28*

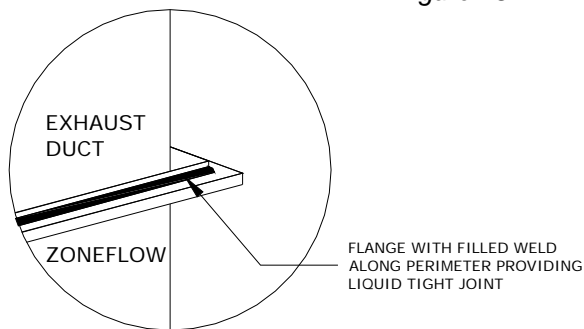

Flange with Filled Weld around perimeter to Zoneflow is also permitted

Butt welded connections are not permitted.

Telescoping joints are not permitted as they may interfere with the interior Zoneflow damper.

The welded connection to the duct work can be either "Flange Edge Weld" or "Flange Filled Weld". See the diagrams above.

*ZM Zoneflow Filled Weld
Figure 29*

Zoneflow Maintenance

Inspection for grease build-up:

The entire exhaust systems shall be inspected for grease buildup by a properly trained, qualified, and certified company or person acceptable to the authority having jurisdiction.

Inspection and Maintenance:

The internal components of the Zoneflow shall be inspected and tested by properly trained, qualified, and certified company or person every 6 months or at the frequency recommended in the chart below...

Schedule for Inspection

Type or Volume of Cooking	Inspection Frequency
Systems serving solid fuel cooking operation	Monthly
Systems serving high-volume cooking operations such as 24 hour/day cooking, charbroiling, or wok cooking	Quarterly
Systems serving moderate-volume cooking operations	Semiannually
Systems serving low-volume cooking operations, such as churches, day camps, seasonal businesses, or senior centers	Annually

Chart No. 3

Inspection:

To inspect the ZM-Zoneflow for grease build up see the instructions and schematics below:
Unplug the CAT5 cable from the Zoneflow J-Box.

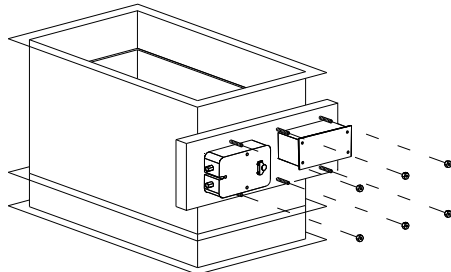

Remove the access door nuts

*ZM Zoneflow Access Door Removal
Figure 30*

The picture to the left shows the ZM Zoneflow access door with the cover shield removed from the damper motor. Once the shield is removed proceed with removing the access door bolts. Remove the Zoneflow access door nuts from the studs complete from the assembly. Save nuts in safe place because they will be reused.

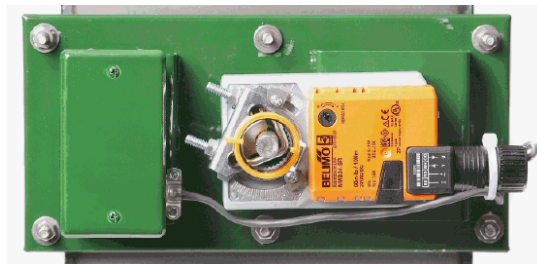

*ZM Zoneflow Access Door with Motor Shield Removed
Figure 31*

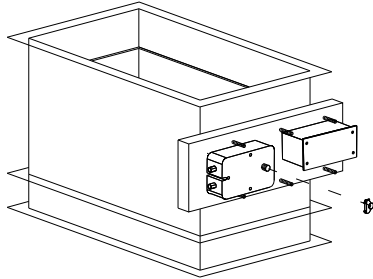

Remove the damper shaft locking U-Bolt

Figure 32

Remove the two nuts that hold the U-Bolt to the Zoneflow internal damper shaft. Save U-Bolt in safe place because it will also be reused.

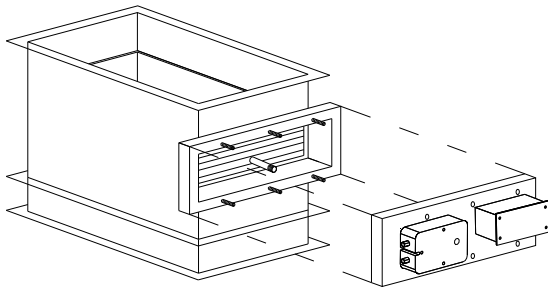

Grasp access door by the right left edges and pull

Figure 33

Grip the Zoneflow Access door with two hands in the middle of the right and left edges. Pull and the access door and it will come free. The access door may resist movement on very heavy grease laden applications. The edges of the access door can be tapped gently with a rubber mallet to release the door.

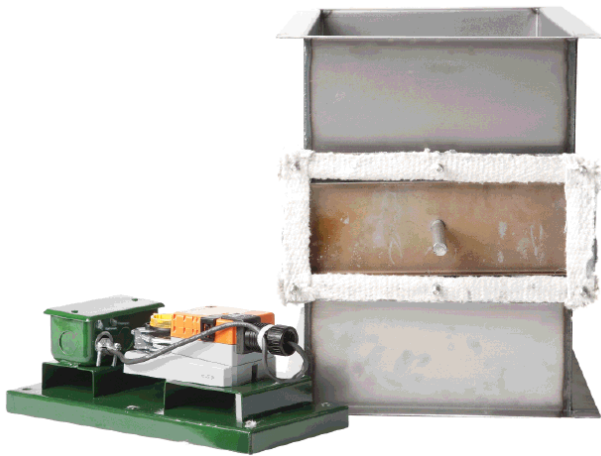

Picture of access door remove exposing high temperature gasketing

Figure 34

There is a strip of high temperature gasketing around the perimeter flange held on by the studs. Inspect the gasketing for deterioration. Replace as required. Replace at least every two years. Set the access door aside.

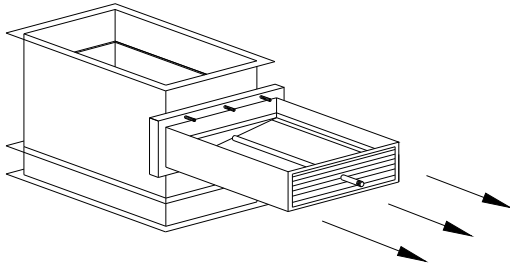

Rotate the damper clockwise until it hits the internal stop, then grab the damper shaft and pull straight out

Rotate the internal damper shaft clockwise closed until the damper hits the interior backstop at the maximum closed position. Holding the damper shaft pull the damper perpendicular to the side of the Zoneflow and inspect the blade.

Figure 35



*Picture of Zoneflow damper partially removed from Zoneflow duct section
Figure 36*



*Picture of Zoneflow damper completely removed from Zoneflow duct section.
Figure 37*

Cleaning:

The damper only needs to be pulled 6 to 12" from the Zoneflow outer wall to inspect for grease build-up. If the blade is completely covered in grease and does not rotate freely remove and wash in a mild detergent and water mixture. If the grease is baked on wash in a pot sink with a mild degreaser.

If cleaning is required completely remove the damper. Do not clean the damper with the access door attached.

Once the damper has been cleaned rotate the shaft clockwise to the maximum closed position and insert back into the ZoneFlow access door opening.

Replace the access door.

Replace the damper shaft U-Bolt with the damper blade rotated fully clockwise to the damper stop position. It is important to re-install the U- Bolt to the shaft with the damper in the minimum damper position so that the signal sent to the damper will provide the correct damper position after this cleaning procedure.

Replace the damper shield if present.

Replace the nuts. Tighten the nuts firmly apply xxxx ft-lb torque. The Zoneflow access door must be secure to the Zoneflow duct to provide a liquid tight seal.

Replace the CAT5 cable.

Inspecting the ZH-Zoneflow for grease build up:

(Similar to the ZM Zoneflow procedure except there is no CAT5 to remove and no J-Box and Damper motor.)

Remove the Zoneflow access door nuts from the studs complete from the assembly. Save nuts in safe place because they will be reused.

Remove the two nuts that hold the U-Bolt to the Zoneflow internal damper shaft. Save U-Bolt in safe place because it will also be reused.

Grip the Zoneflow Access door with two hands in the middle of the right and left edges. Pull and the access door and it will come free. The access door may resist movement on very heavy grease laden applications. The edges of the access door can be tapped gently with a rubber mallet to release the door.

There is a strip of high temperature gasketing around the perimeter flange held on by the studs. Inspect the gasketing for deterioration. Replace as required. Replace at least every two years. Set the access door aside. Rotate the internal damper shaft clockwise closed until the damper hits the interior backstop at the maximum closed position.

Holding the damper shaft pull the damper perpendicular to the side of the Zoneflow and inspect the blade. The damper only needs to be pulled 6 to 12" from the Zoneflow outer wall to inspect for grease build-up. If the blade is completely covered in grease and does not rotate freely remove and wash in a mild detergent and water mixture. If the grease is baked on wash in a pot sink with a mild degreaser.

If cleaning is required completely remove the damper. Once the damper has been cleaned rotate the shaft clockwise to the maximum closed position and insert back into the ZoneFlow access door opening. Replace the access door. Replace the damper shaft U-Bolt with the damper blade rotated fully clockwise to the damper stop position.

It is important to re-install the U- Bolt to the shaft with the damper in the minimum damper position so that the signal sent to the damper will provide the correct damper position after this cleaning procedure. Replace the damper shield if present. Replace the nuts. Tighten the nuts firmly apply xxxx ft-lb torque. The Zoneflow access door must be secure to the Zoneflow duct to provide a liquid tight seal.

Sample Specifications:

ZM Zoneflow:

The Spring Air Systems UL/ULC listed hood shall be supplied with a UL/ULC listed ZoneFlow Modulating damper. The ZoneFlow shall be supplied loose or mounted to the hood duct collar. The ZoneFlow shall be 12" deep in the direct of air flow and match the length and width dimensions of the hood exhaust duct collar. The inlet and out of the ZoneFlow shall have a 1" perimeter flange. The ZoneFlow assembly shall include a bolted access door with high temperature gasket. The access door is easily removable for inspection and cleaning of the ZoneFlow damper and duct interior. The access door shall include a modulating damper motor connected to a junction box with a CAT5 connection. The modulating damper motor requires 24VDC power and a 4-24millamp control signal. The hood shall have 2 incandescent lights evenly spaced along the length of the hood. All lights common to one section of the hood to be inter-wired by Spring Air Systems.

ZH Zoneflow:

The Spring Air Systems UL/ULC listed hood shall be supplied with a UL/ULC listed ZoneFlow Manual damper. The ZoneFlow shall be supplied loose or mounted to the hood duct collar. The ZoneFlow shall be 12" deep in the direct of air flow and match the length and width dimensions of the hood exhaust duct collar. The inlet and out of the ZoneFlow damper shall have a 1" perimeter flange. The ZoneFlow assembly shall include a bolted access door with high temperature gasket. The access door is easily removable for inspection and cleaning of the ZoneFlow damper and duct interior. The access door shall include a locking quadrant for fixing the ZoneFlow balancing damper position. The hood shall have 3 incandescent lights evenly spaced along the length of the hood. All lights common to one section of the hood to be inter-wired by Spring Air Systems.

Other Fine Products From

SPRING AIR SYSTEMS...Solutions for Energy Savings

- Water Wash Ventilators
 - Hot Water Wash
 - Cold Water Spray/Hot Water Wash
 - Water Wash Control Panels
- Dry Extractor Hoods
- RevLow Hoods
- Cartridge Hoods
- Filter Hoods
- Surface Fire Suppression
- Commercial Kitchen Exhaust Fans
- Kitchen Enviro Systems
 - KES - 100% Exhaust
- Commercial Kitchen Supply Units
- Compensating Hoods
- Exhaust Fans
- Supply Fans
- Commercial Kitchen Control Panels
- TruFlow & Melink Variable Speed Exhaust/Supply Systems
- Utility Distributions Systems

Phone: 866-874-4505, FAX: 905-338-0179

info@springairsystems.com

www.springairsystems.com